

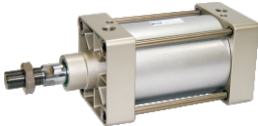
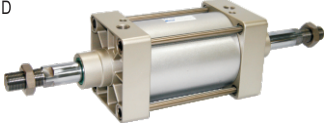
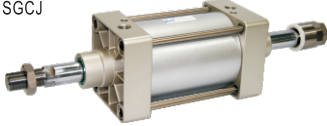

Standard cylinder——SGC Series

In accordance with ISO15552 standard

Product series

Series name	Mounting type									Acting type	Bore size	Collocation of sensor switch	
	Basic	LB	FA	FB	CA	CB	CR	TC	FTC			CS1-B	DS1-B
Double acting type: SGC 	●	●	●	●	●	●	●	●	●	Double acting	125 160 200 250	●	●
Double rod type: SGCD 	●	●	●	●	●	●	●	●	●			●	●
Adjustable stroke type: SGJ 	●	●	●	●	●	●	●	●	●			●	●
Page	184											419	



Installation and application

- When load changes in the work, the cylinder with abundant output capacity shall be selected.
- Relative cylinder with high temperature resistance or corrosion resistance shall be chosen under the condition of high temperature or corrosion.
- Necessary protection measure shall be taken in the environment with higher humidity, much dust or water drops, oil dust and welding dregs.
- Dirty substances in the pipe must be eliminated before cylinder is connected with pipeline to prevent the entrance of particles into the cylinder.
- The medium used by cylinder shall be filtered to 40 μm or below.
- Anti-freezing measure shall be adopted under low temperature environment to prevent moisture freezing.
- The cylinder shall be carried out test run without load before application. Prior to run, buffer shall be turned to the minimum and gradually released to avoid the damage on cylinder caused by excessive impact.
- The cylinder shall avoid the influence of side load in operation to maintain the normal work of cylinder and extend the service life.
- If the cylinder is dismantled and stored for a long time, please conduct anti-rust treatment to the surface. Anti-dust caps shall be added in air inlet and outlet ports.

Criteria for selection: Cylinder thrust

Unit: Newton(N)

Bore size (mm)	Rod size (mm)	Acting type	Pressure area (mm ²)	Operating pressure(MPa)									
				0.1	0.2	0.3	0.4	0.5	0.6	0.7	0.8	0.9	
125	32	Double acting	Push side	12272	1227.2	2454.4	3681.6	4908.8	6136.0	7363.2	8590.4	9817.6	11044.8
		Pull side	11468	1146.8	2293.6	3440.4	4587.2	5734.0	6880.8	8027.6	9174.4	10321.2	
160	40	Double acting	Push side	20106	2010.6	4021.2	6031.8	8042.4	10053.0	12063.6	14074.2	16084.8	18095.4
		Pull side	18849	1884.9	3769.8	5654.7	7539.6	9424.5	11309.4	13194.3	15079.2	16964.1	
200	40	Double acting	Push side	31416	3141.6	6283.2	9424.8	12566.4	15708.0	18849.6	21991.2	25132.8	28274.4
		Pull side	30157	3015.7	6031.4	9047.1	12062.8	15078.5	18094.2	21109.9	24125.6	27141.3	
250	50	Double acting	Push side	49086	4908.6	9817.2	14725.8	19634.4	24543.0	29451.6	34360.2	39268.8	44177.4
		Pull side	47123	4712.3	9620.9	14333.2	19045.5	23757.8	28470.1	33182.4	37894.7	42607.0	



ISO15552 Standard cylinder



SGC Series



Symbol

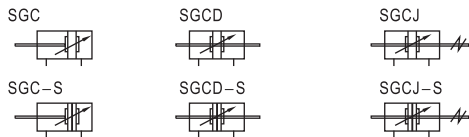

Product feature

1. ISO15552 (original ISO6431) standard cylinder.
2. The piston seal is composed of two Y-shape seals of single-direction structure, which has compensation function, long service life and low start-up pressure.
3. SGC series cylinders are made of aluminum pipe.
4. The buffer adjustment of cylinder is smooth and steady.
5. Cylinders and accessories for installation with several specifications are optional.
6. The seal material with high temperature resistance is adopted to guarantee the normal operation of cylinder at 150°C.

Specification

Bore size(mm)	125	160	200	250
Acting type	Double acting			
Fluid	Air(to be filtered by 40 μm filter element)			
Mounting type	SGC	Basic FA FB CA CB CR LB TC FTC TCM1 TCM2		
	SGCD, SGCJ	Basic FA LB TC FTC TCM1 TCM2		
Operating pressure	0.1~1.0MPa(15~145psi)(1.0~10.0bar)			
Proof pressure	1.5MPa(215psi)(15bar)			
Temperature °C	-20~80			
Speed range mm/s	30~500			
Stroke tolerance	0~250 ^{+1.0} ₀ 251~1000 ^{+1.4} ₀ 1001~1500 ^{+1.8} ₀			
Cushion type	Variable cushion			
Adjustable cushion stroke mm	40	50	60	
Port size ①	1/2"	3/4"	1"	

① PT thread, NPT thread and G thread are available. Add) Refer to P419~442 for detail of sensor switch.

Stroke

Bore size (mm)	Standard stroke (mm)																Max. std stroke	Max. stroke					
	25	50	75	80	100	125	150	160	175	200	250	300	350	400	450	500			600	700	800	900	1000
125	25	50	75	80	100	125	150	160	175	200	250	300	350	400	450	500	600	700	800	900	1000	1500	2000
160	25	50	75	80	100	125	150	160	175	200	250	300	350	400	450	500	600	700	800	900	1000	1500	2000
200	25	50	75	80	100	125	150	160	175	200	250	300	350	400	450	500	600	700	800	900	1000	1500	2000
250	25	50	75	80	100	125	150	160	175	200	250	300	350	400	450	500	600	700	800	900	1000	1500	2000

Note) Consult us for non-standard stroke.

Ordering code

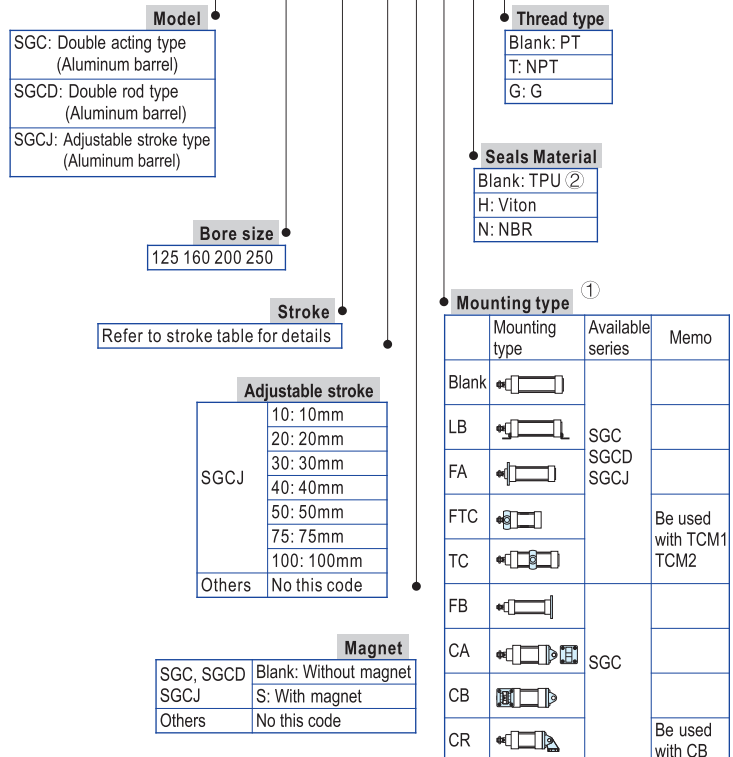
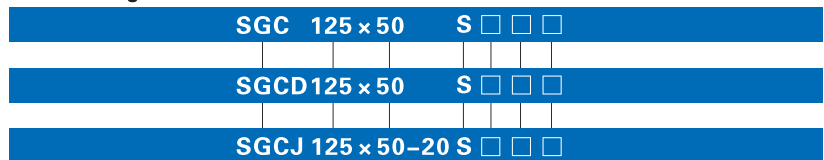

① Please refer to page 186~188 for accessory parts.

② TPU seals are not available for SGC250.



ISO15552 Standard cylinder

SGC Series

Inner structure and material of major parts

SGC

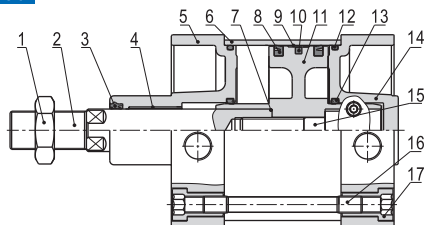

NO.	Item	Material
1	Rod nut	Carbon steel
2	Piston rod	Carbon steel with 20 μ m chrome plated
3	Front cover packing	NBR(SGC250)\TPU(Other)
4	Bushing	Wear resistant material
5	Front cover	Aluminum alloy
6	Aluminum pipe	Aluminum alloy
7	O-ring	NBR
8	Piston seal	NBR
9	Wear ring	Wear resistant material
10	Magnet	Rubber
11	Piston	Aluminum alloy
12	O-ring	NBR
13	Cushion O-ring	NBR(SGC250)\TPU(Other)
14	Back cover	Aluminum alloy
15	Screw	Carbon steel
16	Tie-rod	Carbon steel
17	Tie-rod nut	Carbon steel

Dimensions

SGC

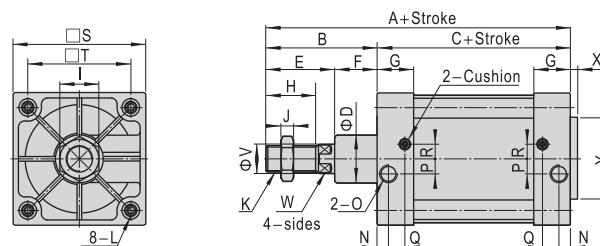

Bore size\Item	A	B	C	D	E	F	G	H	I	J	K
125	279	119	160	60	74	45	46	54	41	13.5	M27×2.0
160	332	152	180	65	94	58	50	72	55	18	M36×2.0
200	347	167	180	75	100	67	50	72	55	18	M36×2.0
250	389	189	200	90	111	78	58	84	65	21	M42×2.0

Bore size\Item	L	N	O	P	Q	R	S	T	V	W	X	Y
125	M12	23	1/2"	14	12	14	140	110	32	27	4	60
160	M16	25	3/4"	15	12	20	180	140	40	36	4	65
200	M16	25	3/4"	15	12	20	220	175	40	36	5	75
250	M20	31	1"	22	13	20	282	220	50	46	8	90

Remark: The dimensions of magnet type cylinder are the same as non-magnet type cylinder.

SGCD

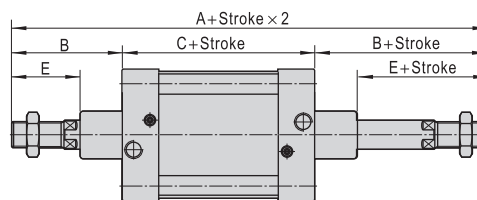

SGCJ

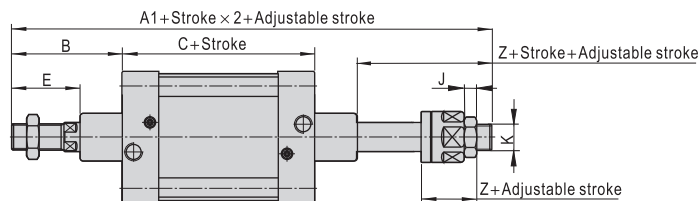

Bore size\Item	A	A1	B	C	E	Z	J	K
125	398	366.5	119	160	74	42.5	13.5	M27X2.0
160	484	458	152	180	94	68	18	M36X2.0
200	514	482	167	180	100	68	18	M36X2.0
250	578	547	189	200	111	80	21	M42X2.0

Remark:
 1. The dimensions of magnet type cylinder are the same as non-magnet type cylinder.
 2. The unmarked dimension is the same as SGC standard type.



SGC

ISO1552 Standard cylinder



Accessories

Ordering code

F-SG 125 TC

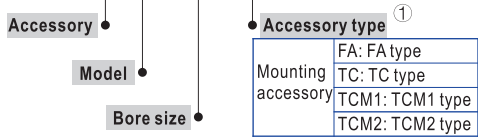

① The listed accessories are for SG cylinder. Accessories that are adaptable to other cylinders are not shown. Please refer to accessory list on P188 for selection and ordering information.

Accessory selection

Accessories	Cylinder model		SGC		SGCD,SGCJ		
	Standard	With magnet	Standard	With magnet	Standard	With magnet	
Mounting accessory	LB	●	●	●	●	●	
	FA	●	●	●	●	●	
	FB	●	●	×	×	×	×
	CA	●	●	×	×	×	×
	CB	●	●	×	×	×	×
	CR	●	●	×	×	×	×
	TC	●	●	●	●	●	●
	FTC	●	●	●	●	●	●
Knuckle ①	I	●	●	●	●	●	
	Y	●	●	●	●	●	
	U	●	●	●	●	●	
	CS1-B	×	●	×	●	●	
Sensor switch ②	CS1-BX	×	●	×	●	●	
	DS1-B	×	●	×	●	●	
	DS1-BN	×	●	×	●	●	
	DS1-BP	×	●	×	●	●	

① Please refer to P415~418 for knuckle detail,

② Please refer to P419~442 for detail of sensor switch.

Material of accessories

Accessories	Mounting accessories											Knuckle		
	LB	FA	FB	CA	CB	CR	TC	FTC	TCM1	TCM2	I	Y	U	
125~200	■	■	■	■	■	■	■	■	■	●	□	□	□	
250	■	■	■	■	■	×	×	×	■	■	■	■	×	

● — Aluminum alloy, ■ — Cast steel,
□ — Carbon steel, × — No this type.

Dimensions

LB

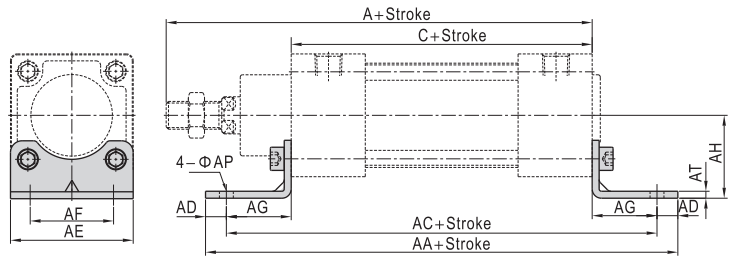

Bore size\Item	A	C	AA	AC	AD	AE	AF	AG	AH	AP	AT
125	279	160	290	250	20	140	90	45	90	16.5	8
160	332	180	340	300	20	180	115	60	115	18.5	8
200	347	180	380	320	30	220	135	70	135	24	9
250	389	200	410	350	30	275	165	75	165	28	19

FA/FB

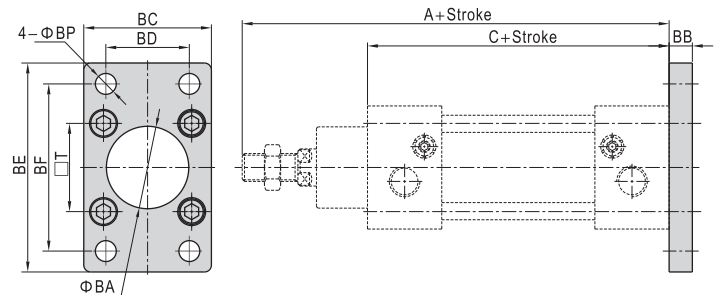
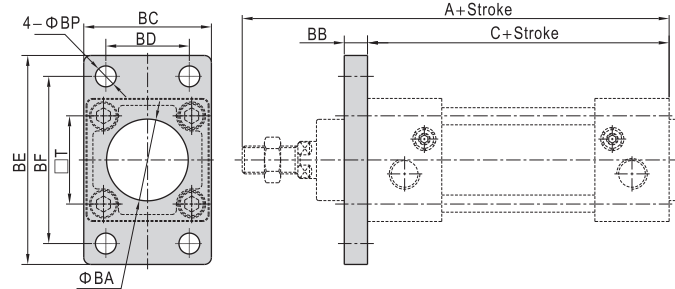

Bore size\Item	A	C	BA	BB	BC	BD	BE	BF	BP	T
125	279	160	60.5	20	139	90	218	180	16.5	110
160	332	180	65.5	20	180	115	280	230	18.5	140
200	347	180	75.5	25	220	135	320	270	24	175
250	389	200	90.5	25	270	165	380	330	26	220

CA

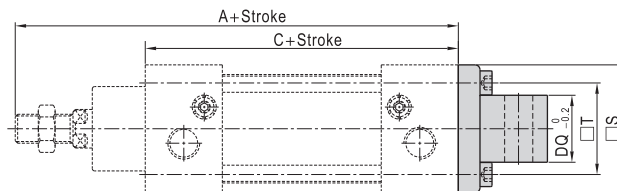

Bore size\Item	A	C	S	T	DC	DD	DE	DJ	DQ
125	279	160	139	110	50	22	25	33	69.7
160	332	180	180	140	55	30	30	35.5	89.7
200	347	180	220	175	60	30	30	37	89.7
250	389	200	270	220	70	35	40	46	109.5

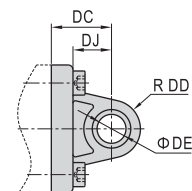

ISO1552 Standard cylinder

Accessories

CB

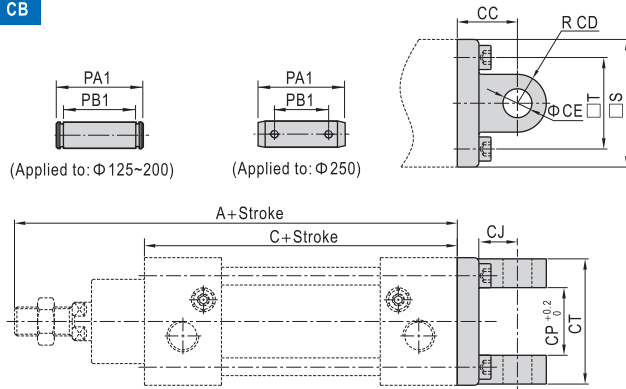

Bore size\Item	A	C	CC	CD	CE	CJ	CP	CT	PA1	PB1	S	T
125	279	160	50	21.5	25	31	70	130	139	130.5	139	110
160	332	180	55	30	30	35.5	90	170	181	170.5	180	140
200	347	180	60	30	30	36	90	170	181	170.5	220	175
250	389	200	70	35	40	46	110.3	200	230	208	270	220

CR

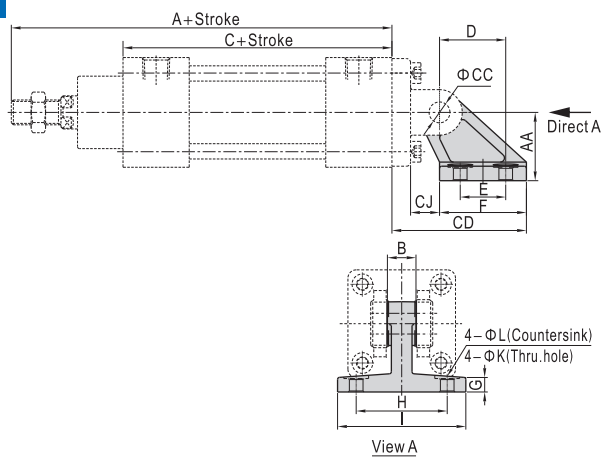

Bore size\Item	A	AA	B	C	CC	CD	CJ	D	E	F	G	H	I	K	L
125	279	90	70	160	25	135	26	70	60	90	20	94	124	14	20
160	332	115	90	180	30	171	25	97	88	126	25	118	156	14	20
200	347	135	90	180	30	185	31	105	90	130	30	122	162	18	26

Note) CR can't be used alone, it must be used with CB.

TC

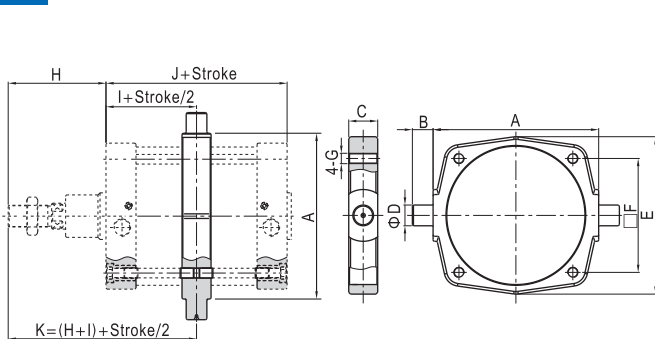

Bore size\Item	A	B	C	D	E	F	G	H	I	J	K
125	160	25	40	25	158.5	110	M12	119	80	160	199
160	200	32	46	32	197.5	140	M16	152	90	180	242
200	250	32	46	32	245	175	M16	167	90	180	257
250	320	40	56	40	304	220	M20	189	100	200	289

Note) CR can't be used alone, it must be used with CB.

FTC

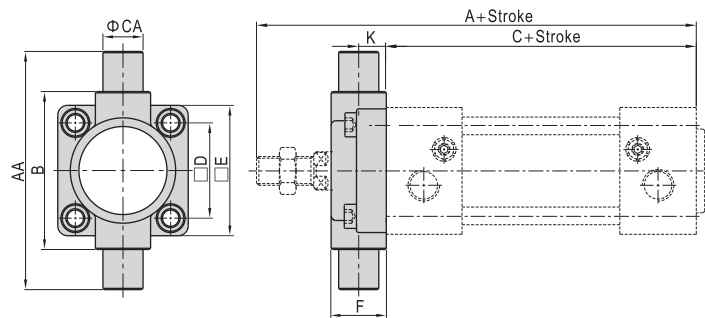

Bore size\Item	A	C	AA	B	CA	D	E	F	K
125	279	160	210	160	25	110	139	43	20
160	332	180	264	200	32	140	179	56	20
200	347	180	314	250	32	175	218	64	20

TCM1

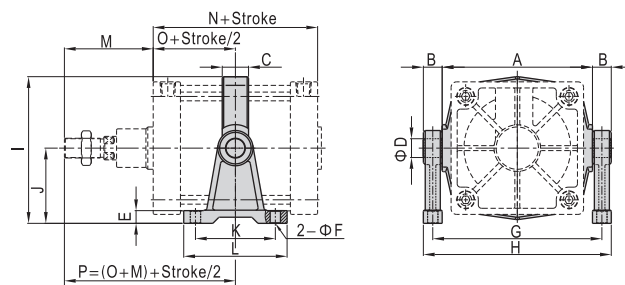

Bore size\Item	A	B	C	D	E	F	G	H	I	J	K	L	M	N	O	P
125	160	25	40	25	19	18	185	213	169.3	90	115	155	119	160	80	199
160	200	32	46	32	24	22	232	267	208.8	110	140	190	152	180	90	242
200	250	32	46	32	27	22	282	317	257.5	135	150	200	167	180	90	257
250	320	40	56	40	27	22	360	400	312	160	170	220	189	200	100	289

Note) The installation position of the accessories can not be adjusted arbitrarily.
When TCM1 be used with FTC, please refer to page 173.

TCM2

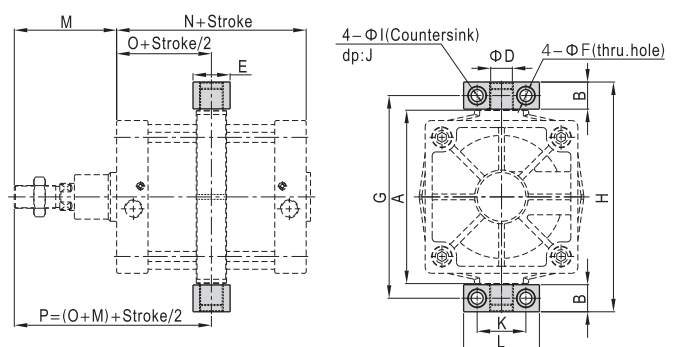

Bore size\Item	A	B	D	E	F	G	H	I	J	K	L	M	N	O	P
125	160	24.5	25	50	14	187.5	212	20	14	50	75	119	160	80	199
160	200	30	32	60	18	234	264	26	17.5	60	92	152	180	90	242
200	250	30	32	60	18	284	314	26	17.5	60	92	167	180	90	257
250	320	50	40	70	22	374	424	33	22	90	140	189	200	100	289

Note) The installation position of the accessories can not be adjusted arbitrarily.
When TCM2 be used with FTC, please refer to page 173.



SGC

ISO1552 Standard cylinder

Accessories

List for ordering code of accessories

Accessories Bore size	Mounting accessory		
	LB	FA FB	CA
125	F-SI125LB	F-SI125FA	F-SI125CA
160	F-SI160LB	F-SI160FA	F-SI160CA
200	F-SI200LB	F-SI200FA	F-SI200CA
250	F-SG250LB	F-SG250FA	F-SG250CA

Accessories Bore size	Mounting accessory		
	CB	CR	TC
125	F-SI125CB	F-SI125CR	F-SG125TC
160	F-SI160CB	F-SI160CR	F-SG160TC
200	F-SI200CB	F-SI200CR	F-SG200TC
250	F-SG250CB	-	F-SG250TC

Accessories Bore size	Mounting accessory		
	FTC	TCM1	TCM2
125	F-SI125FTC	F-SI125TCM1	F-SI125TCM2
160	F-SI160FTC	F-SI160TCM1	F-SI160TCM2
200	F-SI200FTC	F-SI200TCM1	F-SI160TCM2
250	-	F-SG250TCM1	F-SG250TCM2

Accessories Bore size	Knuckle		
	I: I Knuckle	Y: Y Knuckle	U: U Knuckle
125	F-M27X200I	F-M27X200Y	F-M27X200U
160	F-M36X200I	F-M36X200Y	F-M36X200U
200	F-M36X200I	F-M36X200Y	F-M36X200U
250	F-M42X200I	F-M42X200Y	-

Accessories Bore size	Sensor switch				
	CS1-B□	CS1-B□X	DS1-B□	DS1-B□N	DS1-B□P
125	CS1-B1	CS1-B1X	DS1-B1	DS1-B1N	DS1-B1P
160	CS1-B8	CS1-B8X	DS1-B8	DS1-B8N	DS1-B8P
200	CS1-B8	CS1-B8X	DS1-B8	DS1-B8N	DS1-B8P
250	CS1-B5	CS1-B5X	DS1-B5	DS1-B5N	DS1-B5P



SGC