

A wide lineup of measurement ranges capable of solving many applications, from part differentiation to high precision measurement



## I-*Intelligent Sensor* SERIES

Low-cost  
High  
Performance

INTRODUCING THE LASER APPLICATION SENSOR IL SERIES

HEIGHT/ HEIGHT DIFFERENCE	WARPAGE	THICKNESS/WIDTH
POSITIONING	VIBRATION	COUNT



# VARIETY OF USES AT LOW COST

## Compact and lightweight laser displacement sensor



### *Intelligent*

High precision was achieved by using state of the art technology and functions specifically developed for high-accuracy measurement instruments.

### *Rugged*

Developed for use in harsh environments, the IL Series was designed with a robust structure.

### *Easy*

Excellent usability makes it possible to quickly and easily perform stable measurements without any difficult adjustments or settings.



The intelligent I-Series consists of a high-precision sensor lineup that realises low-cost and high performance with only the most advanced functions for on-site operations.



## Introducing the IL Series

*Intelligent Sensor*  
**I-SERIES**

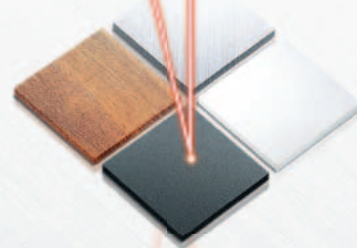

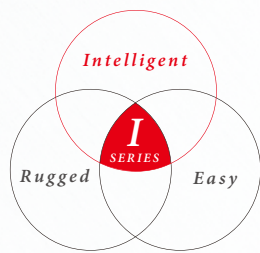

## High-Precision Head + Multi-Function Amplifier

**[Newly developed LSGC included] + [All-in-one design]**

The stable measurement of any given target is possible by sensing the target surface and adjusting the 600,000 times dynamic range. Furthermore, in order to further streamline communication with process control systems we have installed application specific functions into the compact amplifier.

Reduced power

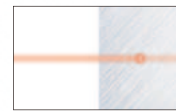

When the workpiece is highly reflective

Increased power



When the workpiece is dark

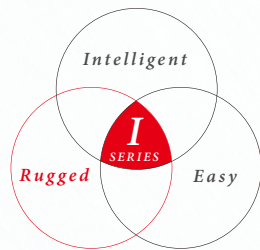
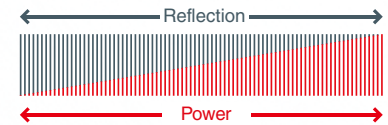

## Rugged Head Structure

**[Die cast metal used for IP67/optical base]**

The head structure was redesigned to make it rugged enough to withstand almost any environment. In addition, the housing is made of die cast SUS304 for added strength and protection.



## Compact Head Design + Easy Mounting

**[Smallest body in its class] + [Hi-flex cable]**

The IL Series has achieved the smallest head housing in its class by adopting the unique aspherical lens. The weight of the head is a mere 60g\*. The sensor head cable is designed with a robot cable. This cable is specifically designed for high cycle service life and makes the sensor ideal for robotics or other high cycle applications.

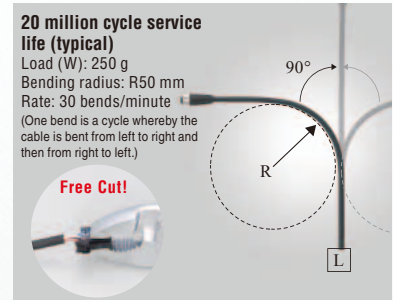

\*IL-030

### IL-600

Reference distance 600 mm  
Measurement range 200 to 1000 mm  
Display Resolution 50  $\mu$ m  
Repeatability 50  $\mu$ m

### IL-300

Reference distance 300 mm  
Measurement range 160 to 450 mm  
Display Resolution 10  $\mu$ m  
Repeatability 30  $\mu$ m

### IL-100

Reference distance 100 mm  
Measurement range 75 to 130 mm  
Display Resolution 2  $\mu$ m  
Repeatability 4  $\mu$ m

### IL-065

Reference distance 65 mm  
Measurement range 55 to 105 mm  
Display Resolution 2  $\mu$ m  
Repeatability 2  $\mu$ m

### IL-030

Reference distance 30 mm  
Measurement range 20 to 45 mm  
Display Resolution 1  $\mu$ m  
Repeatability 1  $\mu$ m

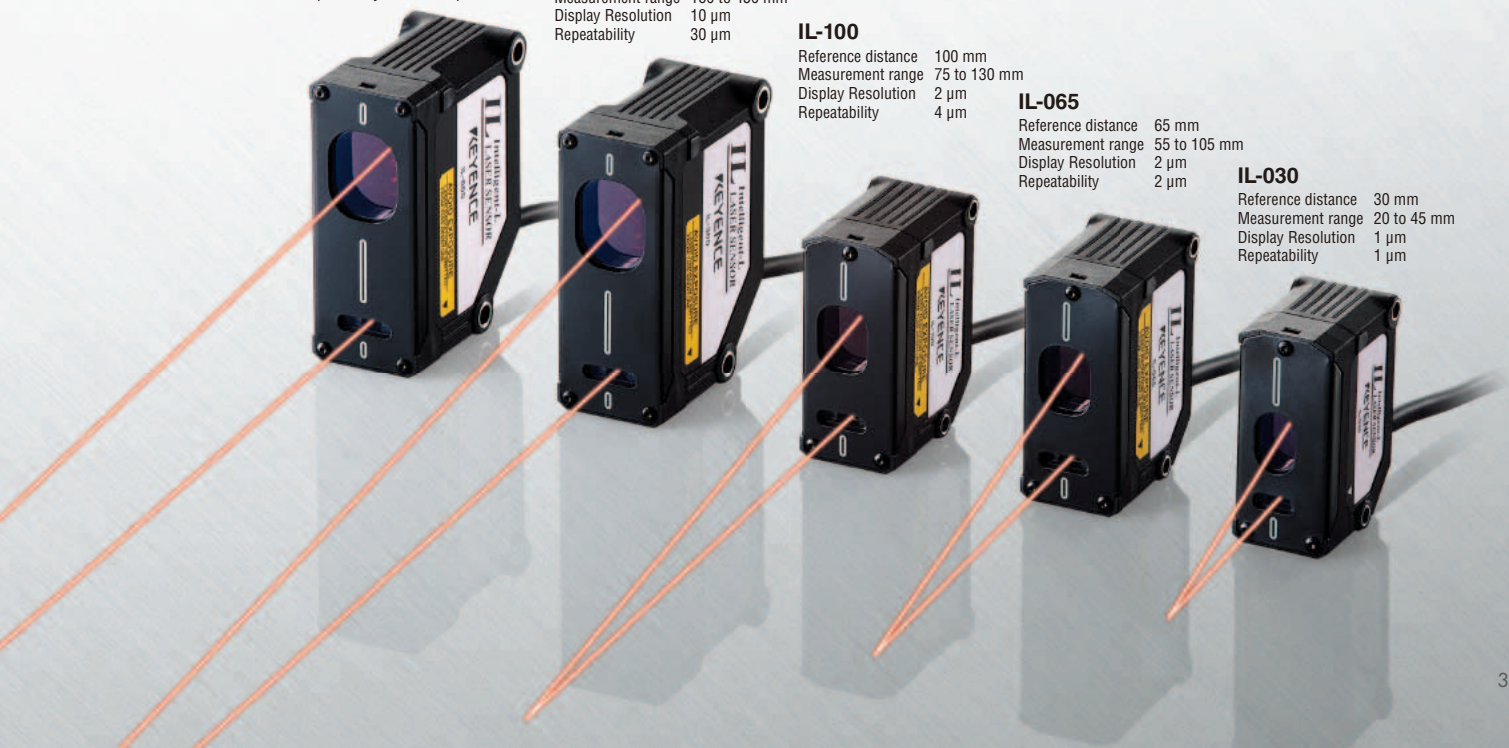

# The multi-function amplifier

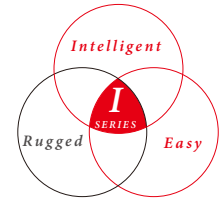

## Calculation function

### Addition mode

**Setting example 1**  
(thickness measurement)

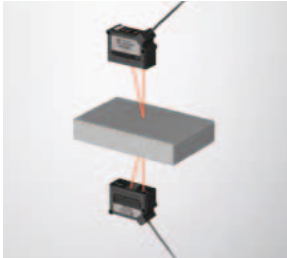

**Setting example 2**  
(width measurement)

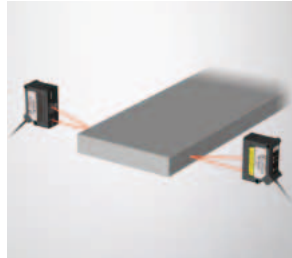

### Subtraction mode

**Setting example 1**  
(Measurement of height difference)

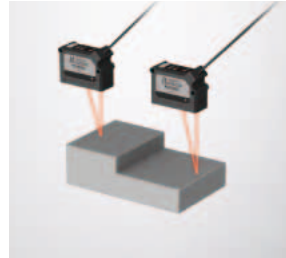

**Setting example 2**  
(Measuring tilt)

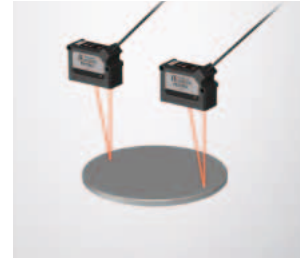

## New mode – Thickness calibration function included

### 3-step easy calibration

With conventional devices, calibration had to be conducted on every individual sensor head, however, the IL Series has a dedicated mode that allows calibration to be completed in 3 simple steps.

*Step 1*

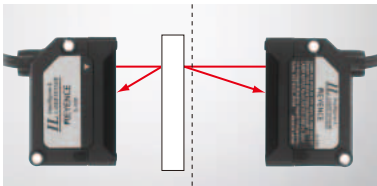

Bring the target close to one sensor head and input the thickness data, then push the set button.

*Step 2*

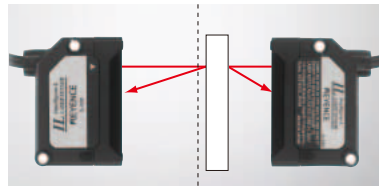

Bring the same target used in Step 1 close to the opposing sensor head and push the set button.

*Step 3*

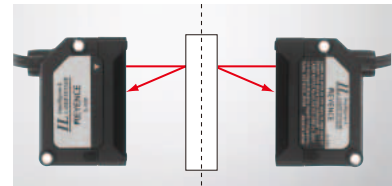

Insert a target thicker than the target used in Step 2. Input the thickness data. Then pushing the set button completes calibration.

When bringing the target closer to the sensor head in Steps 1 and 2, you are compensating for the misalignments that occur during installation. To set, you can begin with either one of the sensor heads.

## Ambient light elimination function included

In order to counteract any ambient light interference, the IL Series automatically activates the ambient light elimination function when the sampling cycle is set to '2 ms' or '5 ms', reducing the effects of ambient light.

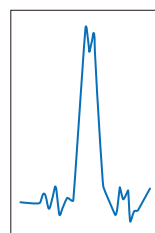
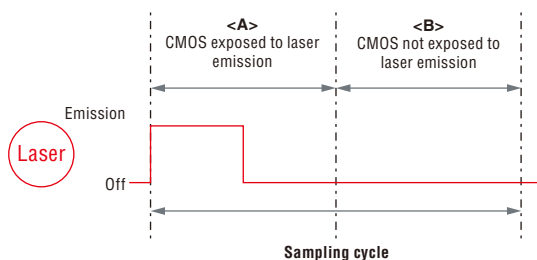

**The CMOS waveform of A**  
Ambient light is present

(Minus)

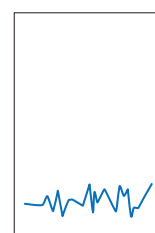

**The CMOS waveform of B**  
Ambient light only

(Equals)

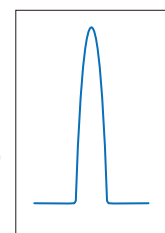

**CMOS waveform (difference)**  
Waveform where the ambient light has been removed

## Function choices

### NPN/PNP Output Selection (judgment selection)

Both NPN and PNP outputs are supported. The outputs are set the first time the user turns on the power. These settings can subsequently be changed. Judgments are output as HIGH, GO, or LOW.

### Analogue Output Selection

The following five types of analogue outputs can be selected. The output is selected the first time the user turns on the power.

Setting value	Description
OFF	Not output
0-5V	Analogue output after the judgement value is converted to the range from 0 to 5 V.
-5-5V	Analogue output after the judgement value is converted to the range of ±5 V.
1-5V	Analogue output after the judgement value is converted to the range from 1 to 5 V.
4-20mA	Analogue output after the judgement value is converted to the range from 4 to 20 mA.

The setting can be changed.

### Bank Function

The bank function can register up to four patterns of specific settings.\* For example, in response to a measurement target changeover, this function allows the user to easily switch between the patterns of registered settings.

\* HIGH setting value, LOW setting value, shift value, analogue output scaling setting

### Mounting method options

Both panel and DIN-rail mount units are available.



IL-1500/1550  
Panel mount type



IL-1000/1050  
DIN-rail mount type

## Height difference count filter function included NEW

This function identifies step edges automatically and delivers one-shot output for each step. Create settings for count and seam detection applications easily, without the programming hours.

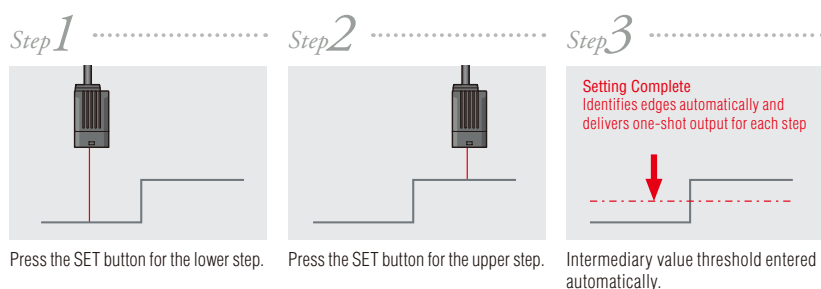

Count the number of sheets of printed material

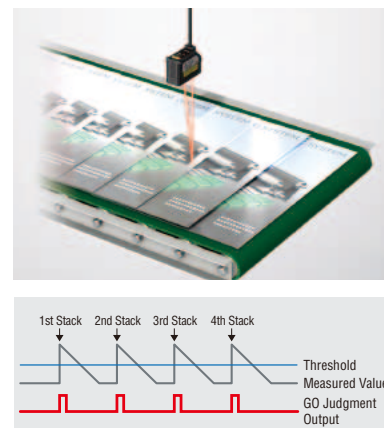

## High pass filter function included NEW

This function displays frequencies above the adjustable cutoff frequency and ignores changes below that cutoff. It is effective for discarding smooth fluctuations and looking only at rapid changes.

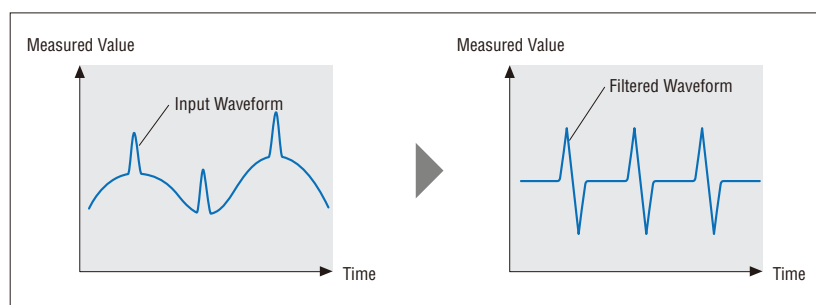

Detection on the edge of a sheet



# COMMUNICATION UNIT

## Direct connection with peripheral equipment

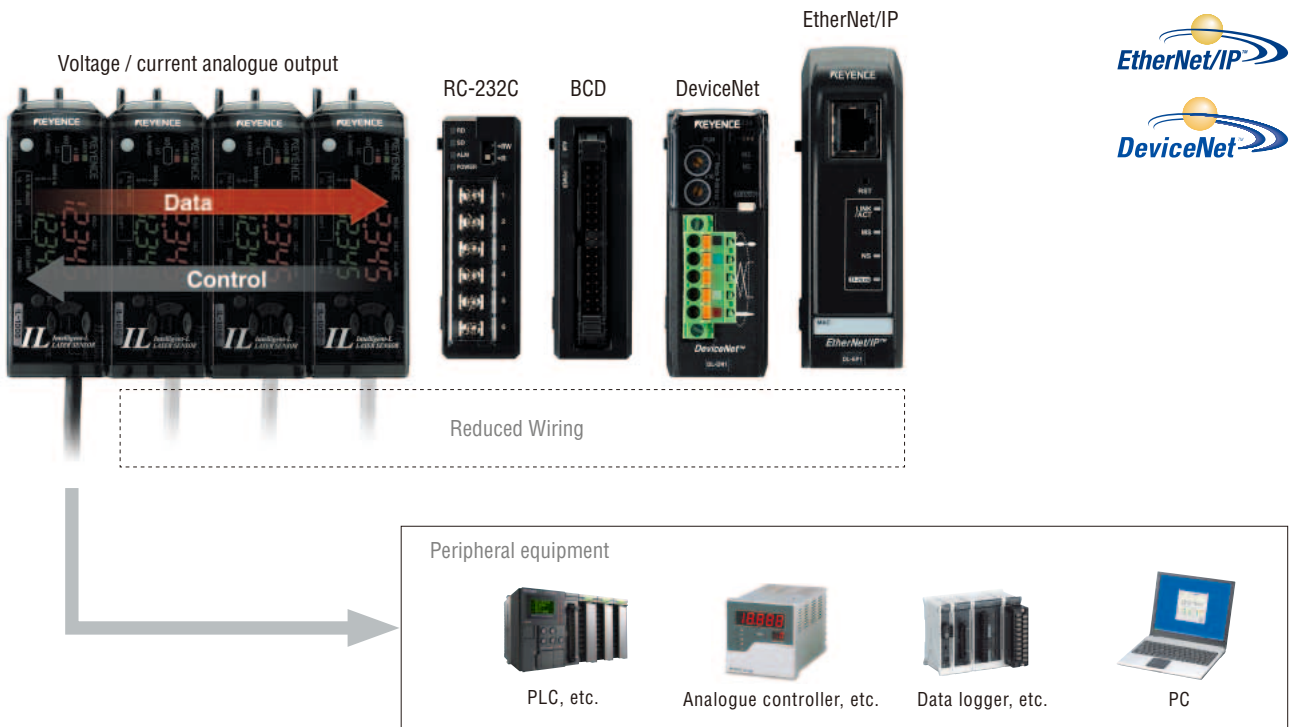

## Communication Unit Variations



### DL-EP1

EtherNet/IP Unit

Cyclic communication makes live data acquisition easy. In addition, message communications allows easy setting changes.



### DL-DN1

DeviceNet Unit

Cyclic I/O Communication makes status monitoring simple. In addition, Explicit Messaging capability allows easy setting changes.



### DL-RS1A

RS-232 Unit

RS-232C communication protocol allows universal compatibility with any device capable of decoding ASCII communications.



### DL-RB1A

BCD Output Unit

The measured value can be synchronised with a trigger input or updated via a timer. Output values are synchronised with the strobe output.

## Optional

Type	Appearance	Model	Description	Weight
End unit (Optional)		OP-26751	To connect an additional expansion unit, use the end units to secure the display units on both ends. When connecting additional units, be sure to use the end units. (2 pcs.)	Approx. 15g
Panel front protection cover [Included in panel mount type amplifier]		OP-87076	The panel front protection cover and panel mounting bracket are included in the panel mount type amplifier. If the supplied cover or bracket is lost or damaged, purchase a new one.	Approx. 6g
Panel mounting bracket [Included in panel mount type amplifier]		OP-4122		Approx. 7g
Expansion cable: 300 mm		OP-35361	Extension cable used for panel mount type amplifier. Use this cable if the standard cable is not long enough.	Approx. 10g
DIN-rail mounting bracket		OP-60412	The mounting bracket is used when the expansion cable is used to connect to the panel mount type display unit, in which case a DIN rail is not provided.	Approx. 12g

## APPLICATIONS

### Height difference measurements of a plastic extrusion

Provides constant monitoring by measuring the height using 2 sensors simultaneously, then calculates the height difference using the calculation function in the amplifier. Reliable detection is possible even if the product type or colour changes.

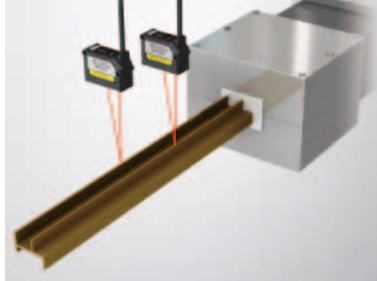

### Warpage detection in ceramic boards

As the sensor head is compact, multiple point measurements of small-scale boards are possible. By calculating the measurement data externally, simultaneous measurements of positioning and warpage are possible.

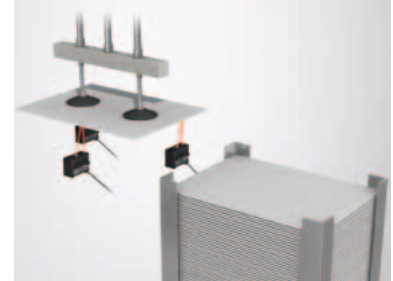

### Thickness/width measurements of building material boards

Thickness and width can be simultaneously measured immediately after the extrusion process. In addition, man-hours for setup and product changeovers are reduced using the thickness calibration function.

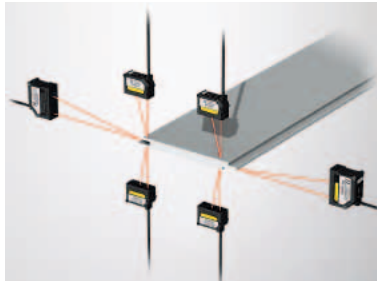

### Packaging material counting

Even in targets with a large amount of shape scatter, reliable counts can still be achieved by detecting rising edges.



### Accuracy checks on an automotive door assembly

When assembling automotive doors, by simultaneously measuring multiple points, the assembly accuracy can be evaluated. Reliable detection is possible regardless of body colour.



### Positional control of welding beads

Through external calculations of height data from the sensor, the device detects the position of the weld seam. Welding accuracy can be improved via measurement data feedback to the welder.



### Heat processing inspection of cans

By observing the expansion displacement of a can after heat processing, the results of heat processing can be evaluated. Reliable differentiation can still be conducted even if there are colour changes in the cans.

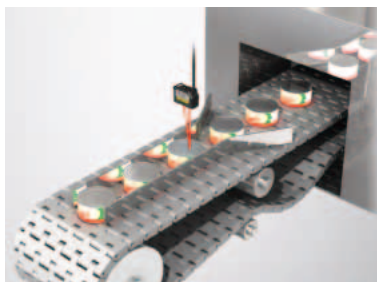

### Height controls of a hoop material

By using a long range type of sensor head, it is possible to control height of hoop materials such as steel plates and sheet materials even during transportation. The sensor head can be installed at a distance of up to 1000 mm.

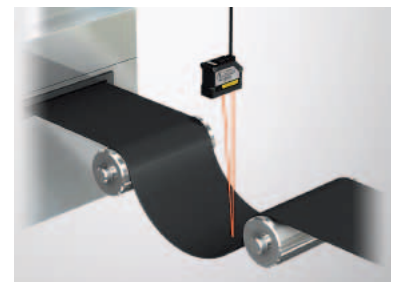

## APPLICATIONS

### Differentiation of different types of plastic components

Reliable differentiation, even in highly variable small parts, using a high-precision sensor head. Even when the variety changes, external changeover of up to 4 patterns is possible by setting items in the bank function.

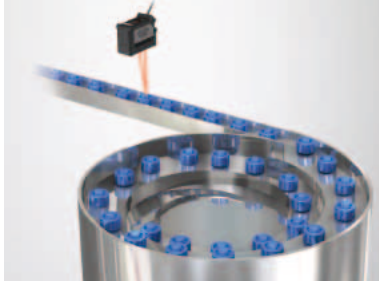

### Stacker counting & uneven checks

The IL Series counts how many items are being transported along a conveyor, in addition to the non-contact detection of uneven stacking in the stacker. Reliable detection regardless of colour changes in the targets.



### Wire winding process

Prevents irregular winding by monitoring the traverser position. In addition, feedback control to the device is possible by measuring the volume wound into the bobbin at the same time.

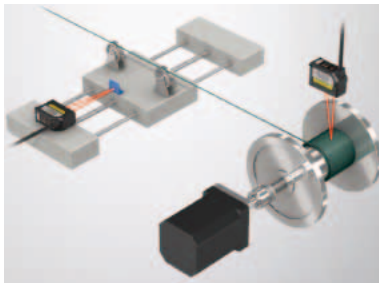

### Height controls of a PC board

Controls the PC board height in the mounting and drilling processes. Various kinds of targets can be reliably controlled without being affected by the surface colours of the PC boards.

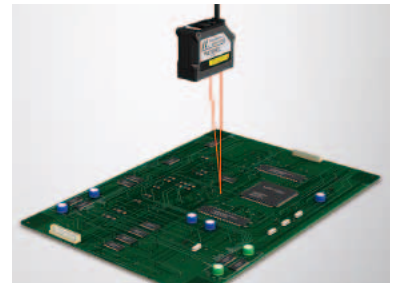

### Detection of stage inclination prior to furnace transportation

Calculates the inclination by measuring multiple points on the stage prior to transferring to the furnace. Transferring the product after correcting the inclination allows for consistent temperature control.

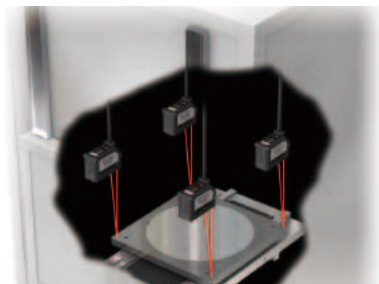

### Wafer measurement inside an inspection machine

Measures the behaviour of each wafer in the machine. Due to the small head size, the IL Series can be installed in compact spaces. This means the IL Series can be installed even after the machinery has been set up.

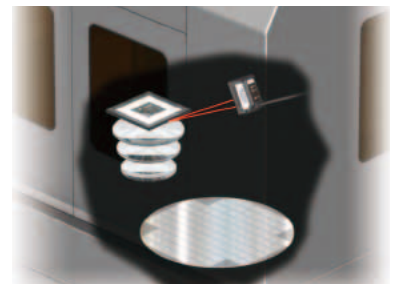

### Misalignment measurement and presence detection of a wafer/glass in a cassette.

Measures the presence and protrusion of glass in a cassette. Stable detection is possible even if positional misalignments occur in the cassette itself by utilising analogue processing.

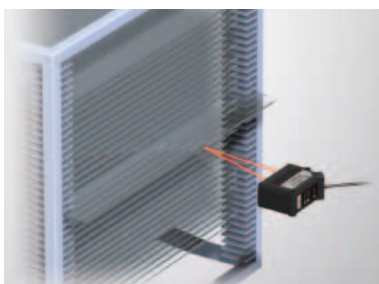

### Measuring the height of a chip after bonding

Measures the height of the board pre-bonding and the chip post-mounting, allowing control of the post-processing suction nozzle and dispenser nozzle feedback.





## APPLICATIONS

### Control welding torch height

Control the height of welding torches. Boost welding precision through constant, exhaustive monitoring.

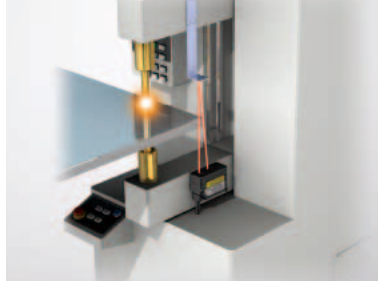

### Press stroke control

Proactively prevent press defects by constantly monitoring the amount of press strokes and the bottom dead centre of presses. Use a long range head to enable compatibility with large-sized pressing machine.

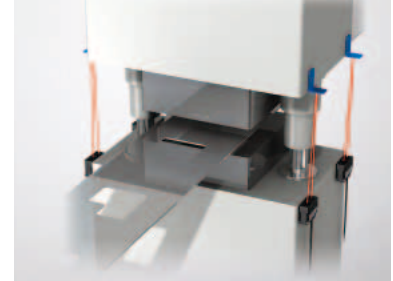

### Robot arm positioning

Detect robot arm chuck precision on the X-, Y- and Z-axes. The long range head enables detection from long distances.



### Traverser stroke control

Prevent rolling disorders by controlling traverser strokes while measuring the amount that bobbins roll to provide feedback to the instrument.

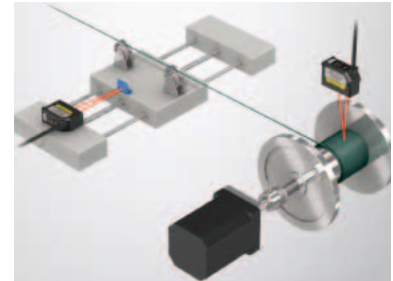

### Detecting welding seams

Detect welding seams on steel plates. The Height Difference Count Filter Function enables stable detection.

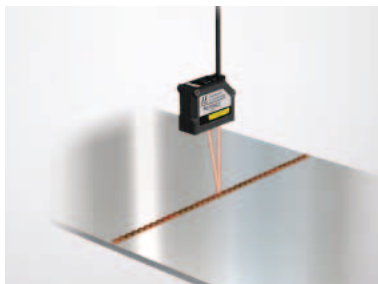

### Rubber sheet seam detection

Detect welding seams on steel plates. The Height Difference Count Filter Function enables stable detection.

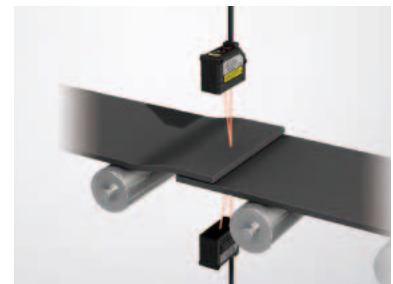

### Counting air conditioner filter sheets

Count the number of air conditioner filter sheets. The High Pass Filter Function enables stable detection, even for workpiece whose height is not constant.



### Liquid level detection in a tank of chocolate

This device constantly monitors the level of liquid surfaces without contacting the liquid. Using a long range head makes it possible to detect levels from far away, even in tight spaces.



Introducing a new high-performance head for the IL Series  
Stable performance for the most demanding detection

## *IL-S Sharp-Line Sensor Heads* NEW

The transmitter is equipped with a cylindrical lens that enables sharp-line beams.

We have overhauled the signal processing inside the head and equipped the device with a Super-Resolution Algorithm so that it is the highest-functioning model in its class.

### IL-S025

Reference distance 25 mm  
Measurement range 20 to 30 mm  
Repeatability 1  $\mu$ m

### IL-S065

Reference distance 65 mm  
Measurement range 55 to 75 mm  
Repeatability 2  $\mu$ m



Equipped with Industry First Super-Resolution Algorithm

Linearity  $\pm 0.05\%$  of F.S. Highest in its Class

Dynamic Range (x1.5 million) Highest in its Class

# Equipped with three functions that enable maximum stability

## Super-resolution algorithm included Industry First

This algorithm identifies differences in CMOS received light waveforms generated by changes in surface conditions of target workpiece and automatically processes waveforms in the best manner possible. Now, you can perform stable detection without tuning, even on metal hairlines, plastic, rubber and other workpiece that has always been difficult to detect.

### SUPER-RESOLUTION DEFINED

The shape of waveforms transmitted to CMOS depends on workpiece material and surface conditions. Before, stability also differed because the same setting was used on different workpiece. The Super-Resolution Algorithm identifies the width of waveforms and automatically performs the setting best suited for the shape of waveforms.

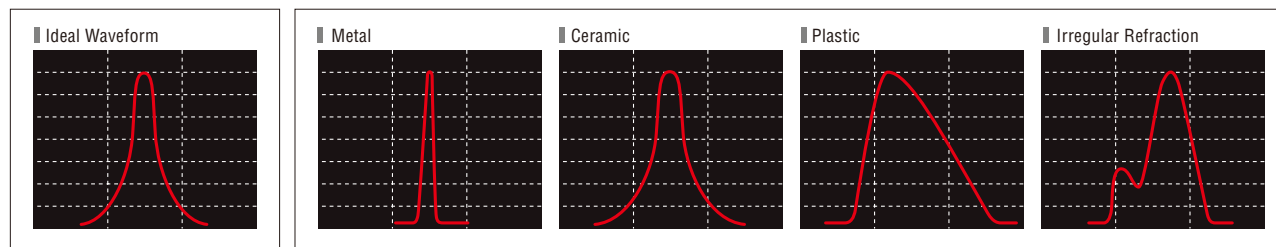

## SCAN function with wide dynamic range

### SCAN (=Sensitive-laser Control Analyser)

The laser power, shutter time and reception gain on this device are adjust in real-time in order to deliver stable detection faithfully for all targets. We also developed a new digital circuit that enables a dynamic range of x1.5 million, 2.5 times higher than past models. Real-time controls that suit targets and their surface conditions enable stable detection.

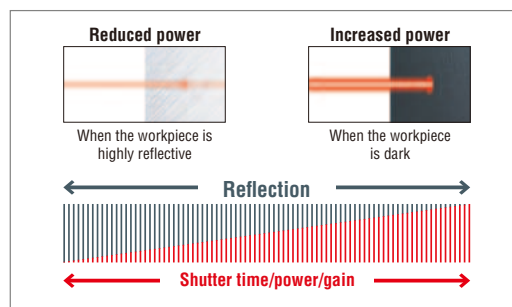

## Sharp-Line Beam

KEYENCE's original optical system pushes the beam diameter to the limits (25 μm), and its sharpness enables the most excellent stability in history. We have overhauled and optimised our optical system for spot profiling for stability in applications that, until now, yielded very erratic results.

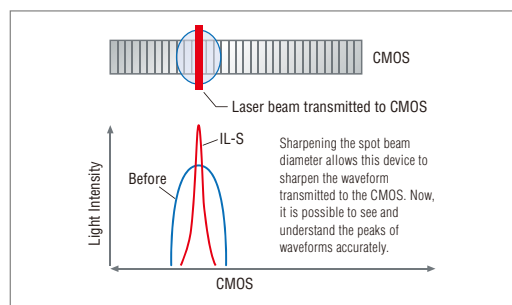

## Application

### Detecting welding seams

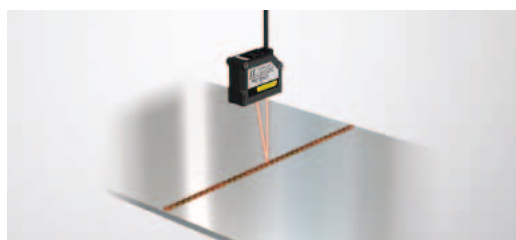

Detect welding seams on steel plates. The Height Difference Count Filter Function enables stable detection.

### Control marking height



Control the distance between the head of marking instruments and workpiece. This device enables stable detection, even for different target workpiece.

# SPECIFICATIONS



## Sensor heads

Model	IL-S025	IL-S065
Reference distance	25 mm	65 mm
Measurement range	20 to 30 mm	55 to 75 mm
Red semiconductor laser, wavelength: 655 nm (visible light)		
Light source	Laser class	Class 2 (FDA (CDRH) Part1040.10) <sup>1</sup> Class 2 (IEC 60825-1)
	Output	560 μW
Spot diameter (at standard distance)	Approx. 25×1200μm	Approx. 55×1700μm
Linearity <sup>2,3</sup>	±0.075% of F.S.(20 to 25 mm) ±0.1% of F.S.(20 to 30 mm)	±0.05% of F.S.(55 to 65 mm) ±0.075% of F.S.(55 to 75 mm)
Repeatability <sup>4</sup>	1 μm	2 μm
Sampling rate	0.33/1/2/5 ms (4 levels available)	
Operation status indicators	Laser emission warning indicator: Green LED, Analogue range indicator: Orange LED, Reference distance indicator: Red/Green LED	
Temperature characteristics <sup>3</sup>	0.03% of F.S./°C	0.02% of F.S./°C
Environmental resistance	Enclosure rating	IP67
	Ambient light <sup>5</sup>	Incandescent lamp: 10000 lux
	Ambient temperature	-10 to +50°C (No condensation or freezing)
	Relative humidity	35 to 85% RH (No condensation)
	Vibration	10 to 55 Hz Double amplitude 1.5 mm XYZ each axis: 2 hours
Pollution degree	3	
Material	Housing material: PBT, Metal parts: SUS304, Packing: NBR, Lens cover: Glass, Cable: PVC	
Weight	Approx. 60g	Approx. 75g

- The laser classification for FDA (CDRH) is implemented based on IEC 60825-1 in accordance with the requirements of Laser Notice No.50.
- Value when measuring the KEYENCE standard target (white diffuse object).
- F.S. of each model is as follows. IL-S025: ±5 mm IL-S065: ±10 mm
- Value when measuring the KEYENCE standard target (white diffuse object) at the reference distance, sampling rate: 1 ms, and average number of times: 128.
- Value when the sampling rate is set to 2 ms or 5 ms.



## Sensor heads

Model	IL-030	IL-065	IL-100	IL-300	IL-600
Reference distance	30 mm	65 mm	100 mm	300 mm	600 mm
Measurement range	20 to 45 mm	55 to 105 mm	75 to 130 mm	160 to 450 mm	200 to 1000 mm
Red semiconductor laser, wavelength: 655 nm (visible light)					
Light source	Laser class	Class 1 (FDA (CDRH) Part1040.10) <sup>1</sup> Class 1 (IEC 60825-1)	Class 2 (FDA (CDRH) Part1040.10) <sup>1</sup> Class 2 (IEC 60825-1)		
	Output	220 μW	560 μW		
Spot diameter (at standard distance)	Approx. 200 × 750 μm	Approx. 550 × 1750 μm	Approx. 400 × 1350 μm	Approx. ø0.5 mm	Approx. ø1.6 mm
Linearity <sup>2,3</sup>	±0.1% of F.S. (25 mm to 35 mm)	±0.1% of F.S. (55 mm to 75 mm)	±0.15% of F.S. (80 mm to 120 mm)	±0.25% of F.S. (160 mm to 440 mm)	±0.25% of F.S.(200 to 600 mm) ±0.5% of F.S.(200 to 1000 mm)
Repeatability <sup>4</sup>	1 μm	2 μm	4 μm	30 μm	50 μm
Sampling rate	0.33/1/2/5 ms (4 levels available)				
Operation status indicators	Laser emission warning indicator: Green LED, Analogue range indicator: Orange LED, Reference distance indicator: Red/Green LED				
Temperature characteristics <sup>3</sup>	0.05% of F.S./°C	0.06% of F.S./°C	0.06% of F.S./°C	0.08% of F.S./°C	
Environmental resistance	Enclosure rating	IP67			
	Ambient light <sup>5</sup>	Incandescent lamp: 5000 lux	Incandescent lamp: 7500 lux	Incandescent lamp: 5000 lux	
	Ambient temperature	-10 to +50°C (No condensation or freezing)			
	Relative humidity	35 to 85% RH (No condensation)			
	Vibration	10 to 55 Hz Double amplitude 1.5 mm XYZ each axis: 2 hours			
Pollution degree	3				
Material	Housing material: PBT, Metal parts: SUS304, Packing: NBR, Lens cover: Glass, Cable: PVC				
Weight	Approx. 60g	Approx. 75g	Approx. 135g		

- The laser classification for FDA (CDRH) is implemented based on IEC 60825-1 in accordance with the requirements of Laser Notice No.50.
- Value when measuring the KEYENCE standard target (white diffuse object).
- F.S. of each model is as follows. IL-030: ±5 mm IL-065: ±10 mm IL-100: ±20 mm IL-300: ±140 mm IL-600: ±400 mm
- Value when measuring the KEYENCE standard target (white diffuse object) at the reference distance, sampling rate: 1 ms, and average number of times: 128. For the IL-300/IL-600, the sampling rate is 2 ms.
- Value when the sampling rate is set to 2 ms or 5 ms.

# DIMENSIONS

Unit : mm

## Sensor heads IL-S025/IL-030

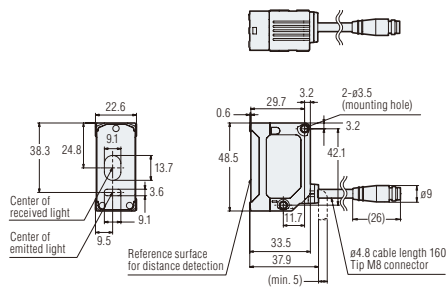

### Mounting bracket (supplied)

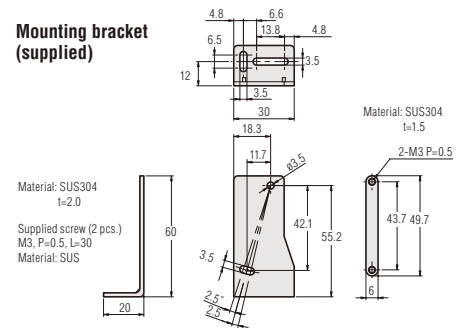

## IL-S065/IL-065/100

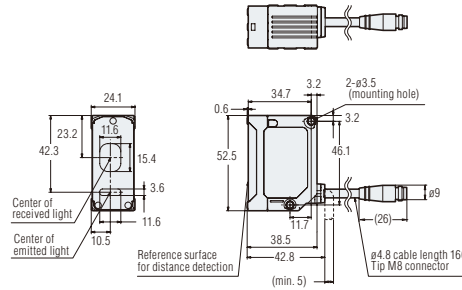

### Mounting bracket (supplied)

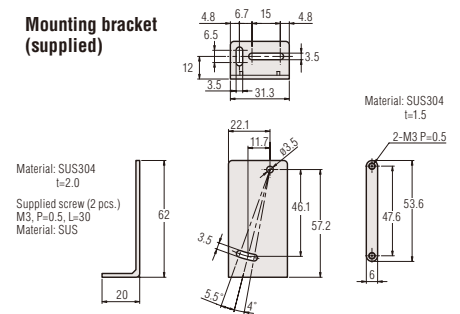

## IL-300/600

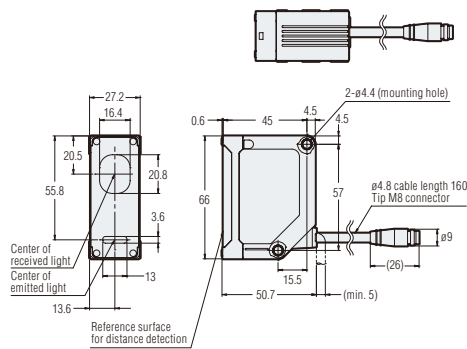

### Mounting bracket (supplied)

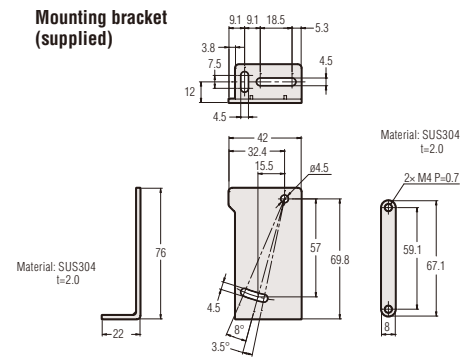

# SPECIFICATIONS

## Amplifier unit

Model	IL-1000	IL-1500	IL-1050	IL-1550
Type	DIN-rail mount	Panel mount	DIN-rail mount	Panel mount
Main unit/expansion unit	Main unit		Expansion unit	
Head compatibility	Compatible			
Display	Minimum displayable unit	IL-S025/IL-030: 1 μm, IL-S065/IL-065/IL-100: 2 μm, IL-300: 10 μm, IL-600: 50 μm		
	Display range	IL-S025/IL-030/IL-S065/IL-065/IL-100: ±99.999 mm to ±99 mm (4 levels selectable), IL-300/IL-600: ±999.99 mm to ±999 mm (3 levels selectable)		
	Display rate	Approx. 10 times/sec.		
Analogue voltage output <sup>1</sup> :	±5 V, 1 to 5 V, 0 to 5 V Output impedance 100 Ω		None	
Analogue current output <sup>1</sup> :	4 to 20 mA Maximum load resistance of 350 Ω			
Control input <sup>2</sup> :	Bank switch input	Non-voltage input		
	Zero-shift input			
	Stop emission input			
	Timing input			
	Reset input			
Control output <sup>3</sup> :	Judgment output	Open collector output (NPN, PNP changeover possible/N.O., N.C. changeover possible)		
	Alarm output	Open collector output (NPN, PNP changeover possible/N.C.)		
Current	Power voltage <sup>4</sup> :	10 to 30 VDC ripple (P-P) 10% included, Class 2 or LPS	Supplied by main unit	
	Power consumption	2300 mW or less (at 30 V: 77 mA or less)	2500 mW or less (at 30 V: 84 mA or less)	2000 mW or less (at 30 V: 67 mA or less)
Environmental resistance	Ambient humidity	-10 to +50°C (No condensation or freezing)		
	Ambient temperature	35 to 85% RH (No condensation)		
	Vibration	10 to 55 Hz Double amplitude 1.5 mm XYZ each axis: 2 hours		
	Pollution degree	2		
Material	Case / Front sheet: Polycarbonate; Key tops: Polyacetal; Cable: PVC			
Weight (including attachments)	Approx. 150g	Approx. 170g	Approx. 140g	Approx. 160g

1. Select and use one of ±5 V, 1 to 5 V, 0 to 5 V or 4 to 20 mA.

2. Assign an input of your choice to the 4 external input lines before using.

3. - The NPN open collector rated output is: 50 mA max./ch (20 mA when adding an expansion unit) less than 30 V, residual voltage less than 1 V (less than 1.5 V when adding over 6 units including the main unit)

- The PNP open collector rated output is: 50 mA max./ch (20 mA/ch when adding expansion units), less than power voltage, and less than 2 V residual voltage (less than 2.5 V when adding over 6 units including the main unit)

4. If there are over 6 additional expansion units, please use a power voltage of 20 to 30 V.

## DIMENSIONS

Unit : mm

### Amplifier unit (DIN-rail mount type) IL-1000/IL-1050

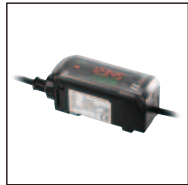

IL-1000

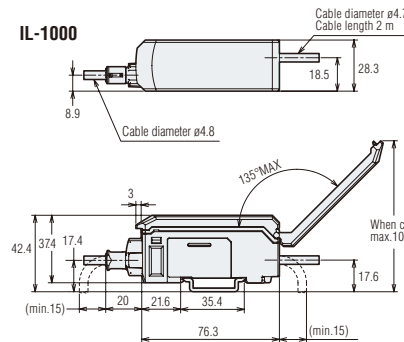

IL-1050

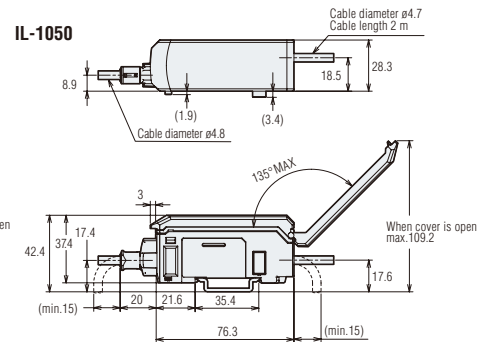

### Amplifier unit (Panel mount type) IL-1500/IL-1550

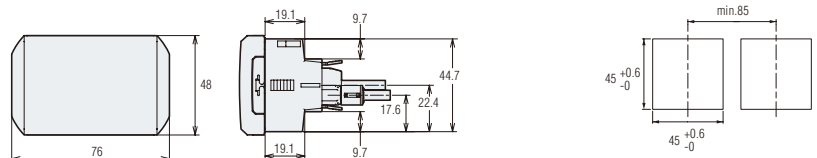
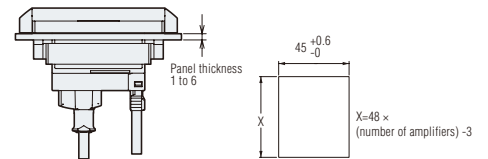
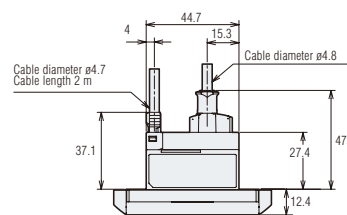

## WIRING DIAGRAM

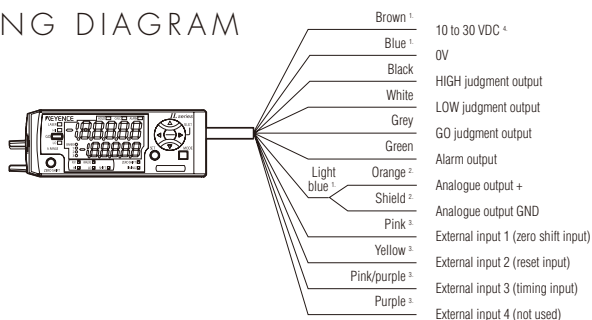

1. The brown, blue, and light blue cables are not provided in a IL-1050/IL-1550 unit (expansion unit).

The power is supplied to the expansion unit from the IL-1000/IL-1500 unit (main unit).

2. For an analogue output, OFF (not used), 0 to 5 V, ±5 V, 1 to 5 V, or 4 to 20 mA can be selected.

3. For an external input, bank A input, bank B input, laser emission stop input, or OFF (not used) can also be selected. For details, refer to the User's Manual.

4. If there are over 6 additional expansion units, please use a power voltage of 20 to 30 V.

# SPECIFICATIONS

## Communication unit (EtherNet/IP)

Model		DL-EP1
Ethernet specifications	Compliant standards	IEEE802.3 (10BASE-T)/IEEE802.3u (100BASE-TX)
	Transmission rate	10Mbps (10BASE-T)/100Mbps (100BASE-TX)
	Transmission medium	STP cable or Category 3 or higher UTP cable (10BASE-T)/STP cable or Category 5 or higher UTP cable (100BASE-TX)
	Maximum cable length	100 m (Distance between DL-EP1 and Ethernet switch)
	Maximum number of connectable hubs	4 (10BASE-T)/2 (100BASE-TX)
EtherNet/IP specifications	Compatible functions	Cyclic communication (Implicit messaging) Message communication (Explicit messaging) Compatible with UCMM and Class 3
	Number of connections	64
	RPI (Transmission cycle)	0.5 to 10000 ms (0.5 ms unit)
	Tolerable communication bandwidth for cyclic communication	6000pps
	Conformance test	Compatible with Version A7
Sensor connection specifications	Connectable sensors	Sensor amplifiers with D-bus support <sup>1</sup>
	Number of connectable sensor units	Up to 8 units
Indicators	Link/activity indicator (LINK/ACT): Green LED, Module status indicator (MS): 2-colour (green/red) LED, Network status indicator (NS): 2-colour (green/red) LED, Sensor communication indicator (D-bus) 2-colour (green/red) LED	
Power voltage	Including 20 to 30 VDC ripple (p-p) 10% (This voltage is supplied from the connected sensor amplifier)	
Power consumption	1500 mW or less (at 30 V 50 mA max)	
Environmental resistance	Operating ambient air temperature	-20 to +55 °C (no freezing)
	Operating ambient air humidity	35 to 85% RH (no condensation)
	Vibration resistance	10 to 55 Hz compound amplitude 1.5 mm, 2 hours each in X, Y, Z directions
	Pollution degree	2
Materials	Main unit case: Polycarbonate	
Weight	Approx. 70g	

## Communication unit (DeviceNet)

Model		DL-DN1	
Communication method		DeviceNet compliant	
DeviceNet specifications	Compliant functions	Remote I/O communication (polling) Explicit messaging	
	Address setting	0 to 63 (PGM compatible).	
	Baud rate (automatically switched)	500 kbps/250 kbps/125 kbps	
	Maximum cable length	500 kbps	100 m for thick cable; 100 m for thin cable
		250 kbps	250 m for thick cable; 100 m for thin cable
		125 kbps	500 m for thick cable; 100 m for thin cable
Network power supply	11 to 25 VDC (supplied from DeviceNet communication power supply)		
Sensor connection specifications	Connectable sensors	Sensor amplifiers with D-bus support <sup>1</sup>	
	Number of connectable sensor units	8 units max.	
Indicators	Network status indicator: 2-colour (green/red) LED, Module status indicator: 2-colour (green/red) LED, Sensor communication indicator: 2-colour (green/red) LED		
Power voltage	20 to 30 VDC, including ripple (P-P) 10% (supplied from the connected sensor amplifiers)		
Power consumption	660 mW or less (at 30 V, 22 mA max.)		
Environmental resistance	Operating ambient temperature	-20 to +55°C (no freezing)	
	Operating ambient humidity	35 to 85% RH (no condensation)	
	Vibration resistance	10 to 55 Hz, compound amplitude 1.5 mm, 2 hours each in X, Y, Z directions	
	Pollution degree	2	
Materials	Main unit case and dust cover: Polycarbonate, DeviceNet connector: Polyamide (plug), PUT (socket)		
Weight (including connectors)	Approx. 80g		

1. "D-bus" is the name of KEYENCE's wiring-saving system for sensor amplifiers.

## Communication unit (BCD output: DL-RB1A/RS-232C: DL-RS1A)

Model		DL-RB1A	DL-RS1A
Power supply voltage		20 to 30 VDC, including ripple, Ripple (P-P): 10% max. Class 2 (Supplied via connected sensor amplifier)	
Power consumption		27 mA max.	25 mA max.
Number of connectable sensor amplifiers		Up to 8 units (including main unit)	
Indicator		Alarm indicator lamp (red), Power indicator lamp (green)	Communication indicator lamp (green × 2), Alarm indicator lamp (red), Power indicator lamp (green)
Communication method		-	Full duplex
Synchronization method		-	Start-stop
Transmission code		-	ASCII
Baud rate		-	2400/4800/9600/19200/38400 bps selectable (Factory-setting: 9600 bps)
Data bit length		-	8 bits/7 bits selectable (Factory-setting: 8 bits)
Parity check		-	None/Even/Odd selectable (Factory-setting: None)
Stop bit length		-	1 bit
Data delimiter		-	Data reception: automatically recognizes CR or CR+LF Data transmission: Fixed to CR+LF
Environment resistance	Ambient temperature	-10 to +55°C	
	Ambient humidity	35 to 85%RH (No condensation)	
	Vibration resistance	10 to 55 Hz Double amplitude 1.5 mm XYZ each axis: 2 hours	
Material	Case/Polycarbonate		
Weight	Approx. 46 g		Approx. 53 g

**Communication unit (EtherNet/IP Unit)**

**DL-EP1**

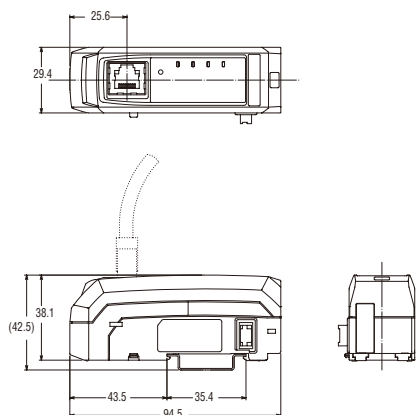

**Communication unit (DeviceNet Unit)**

**DL-DN1**

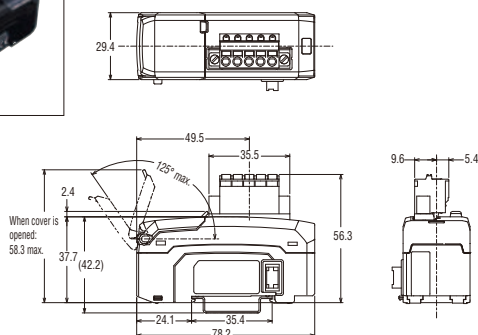

**Communication unit (BCD Output Unit)**

**DL-RB1A**

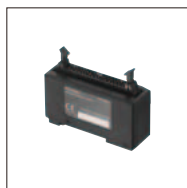

34-pin MIL connector

DIN-rail mount

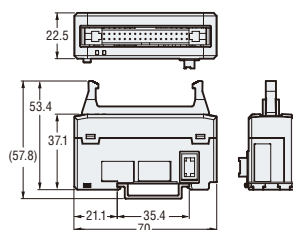

When the mounting bracket is attached  
OP-60412 (Optional)

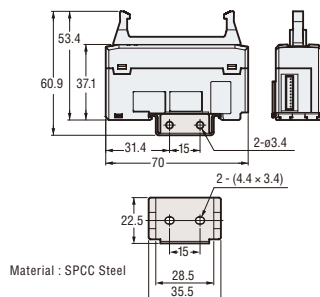

Material : SPCC Steel

**Communication unit (RS-232C Unit)**

**DL-RS1A**



DIN-rail mount

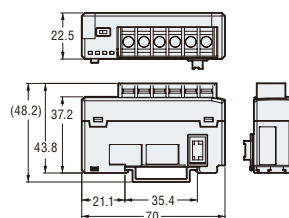

When the mounting bracket is attached  
OP-60412 (Optional)

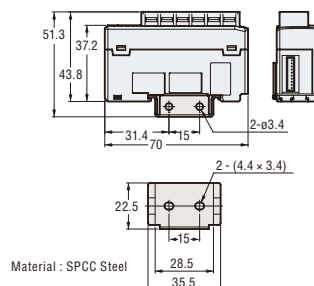

Material : SPCC Steel



CONTACT US  
**+32 1-528-1222**

[www.keyence.eu](http://www.keyence.eu)  
E-mail: [info@keyence.eu](mailto:info@keyence.eu)

**SAFETY INFORMATION**  
Please read the instruction manual carefully in order to safely operate any KEYENCE product.

**KEYENCE INTERNATIONAL (BELGIUM) NV/SA**

Head office Bedrijvenlaan 5, 2800 Mechelen, Belgium Tel: +32 1-528-1222 Fax: +32 1-520-1623

Regional sales offices

**BELGIUM**  
Tel: +32 1-528-1220  
Fax: +32 1-520-1623

**AUSTRIA**  
Tel: +43 22-36-3782-66-0  
Fax: +43 22-36-3782-66-30

**CZECH REPUBLIC**  
Tel: +420 222-191-483  
Fax: +420 222-191-505

**HUNGARY**  
Tel: +36 1-802-73-60  
Fax: +36 1-802-73-61

**NETHERLANDS**  
Tel: +31 40-20-66-100  
Fax: +31 40-20-66-112

**POLAND**  
Tel: +48 71-36861-60  
Fax: +48 71-36861-62

**ROMANIA**  
Tel: +40 269-232-808  
Fax: +40 269-232-808

**SLOVAKIA**  
Tel: +421 2-5939-6461  
Fax: +421 2-5939-6200

**SLOVENIA**  
Tel: +386 1-4701-666  
Fax: +386 1-4701-699

**SWITZERLAND**  
Tel: +41 43-45577-30  
Fax: +41 43-45577-40

**KEYENCE CORPORATION**

1-3-14, Higashi-Nakajima, Higashi-Yodogawa-ku, Osaka, 533-8555, Japan PHONE: +81-6-6379-2211

The information in this publication is based on KEYENCE's internal research/evaluation at the time of release and is subject to change without notice.  
Copyright (c) 2011 KEYENCE CORPORATION. All rights reserved. ILS-KIB-C-E 1121-2 [626018] Printed in Japan

