

Vacuum Pad: Large Size Bellows Type

Series ZPT/ZPX

ø40, ø50, ø63, ø80, ø100, ø125

Ideal for loads with a curved surface,
heavyweight loads and
loads with large surface area.

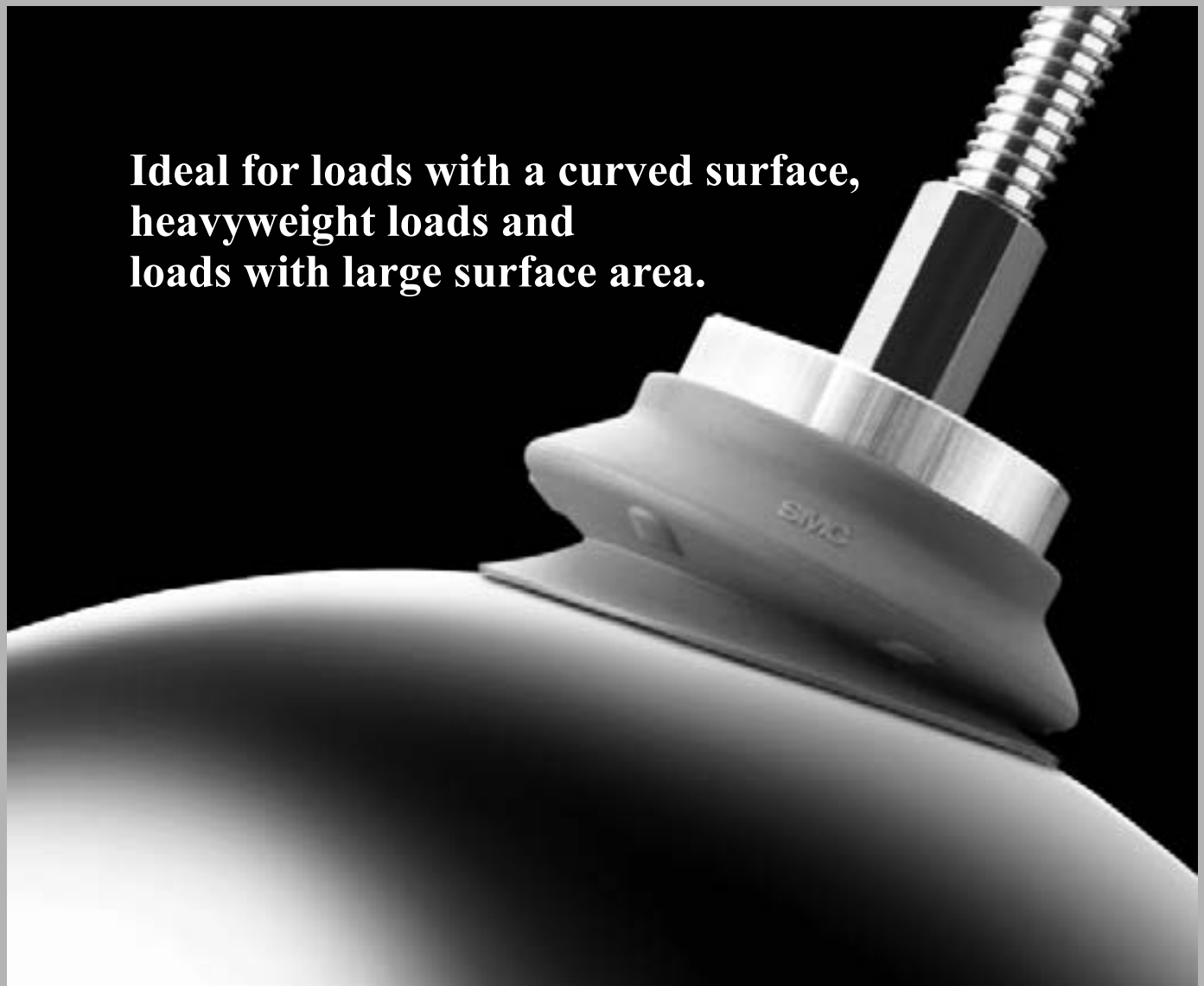

ZA

ZX

ZR

ZM

ZMA

ZQ

ZH

ZU

ZL

ZY□

ZF□

ZP□

SP

ZCUK

AMJ

AMV

AEP

HEP

Related
Equipment

For transfer of CRT

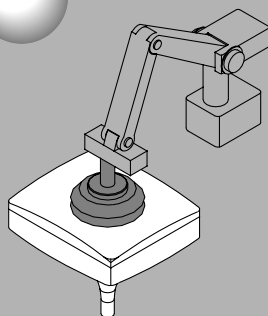

For transfer of
cardboard box

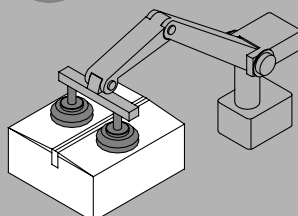

For automotive
production line

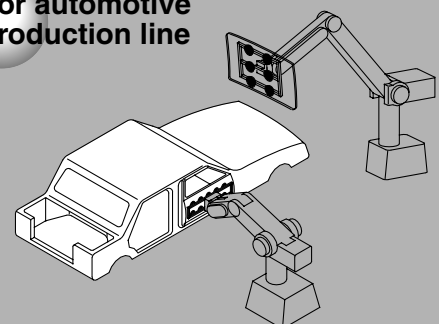

Vacuum Pad: Large Size Bellows Type

Series ZPT/ZPX

Pad diameter: $\phi 40$, $\phi 50$, $\phi 63$, $\phi 80$, $\phi 100$, $\phi 125$

Pad material: NBR, Silicone rubber, Urethane rubber, Fluoro rubber, EPR

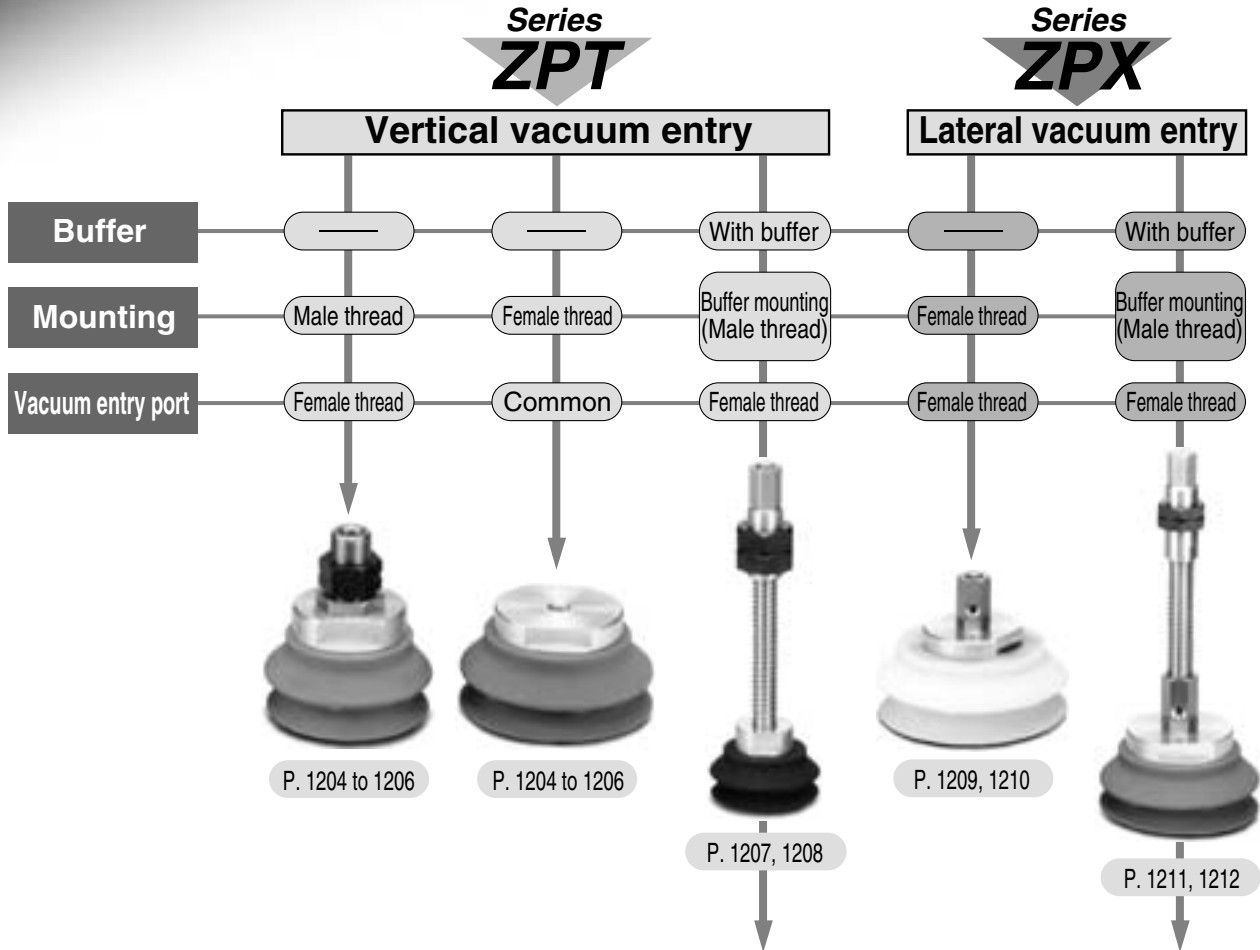

		Buffer stroke					
		Pad dia.					
Buffer stroke (mm)	Pad dia.	$\phi 40$	$\phi 50$	$\phi 63$	$\phi 80$	$\phi 100$	$\phi 125$
25		●	●	●	●	●	●
50		●	●	●	●	●	●
75		●	●	●	●	●	●
100		—	—	—	—	●	●

Pad Material and Characteristics

◎: Little or no influence ○: Can be used depending on conditions. X: Not suitable

Characteristics	Durometer HS ($\pm 5^\circ$)	Operating temperature range ($^\circ\text{C}$)	Oil resistance gasoline	Oil resistance benzol	Base resistance	Acid resistance	Weatherability	Ozone resistance	Abrasion resistance	Waterproof	Solvent resistance (Benzene, toluene)
NBR	50°	0 to 120	◎	×	○	○	×	×	◎	○	×
Silicon rubber	50°	-30 to 200	×	×	○	×	◎	◎	×	○	×
Urethane rubber	60°	0 to 60	◎	×	×	×	○	◎	◎	×	×
Fluoro rubber	60°	0 to 250	◎	◎	×	◎	◎	◎	○	◎	◎
EPR	50°	-20 to 150	×	×	◎	○	◎	◎	○	◎	×

The above table covers only general characteristics of subject rubber materials.

Pad materials used by SMC pass the nominal JIS material standards; however, actual performance depends on operating conditions.



Interchangeable with flat pad with ribs for heavy loads.

When changing to a different shape pad due to load change, the pad can be easily interchanged.

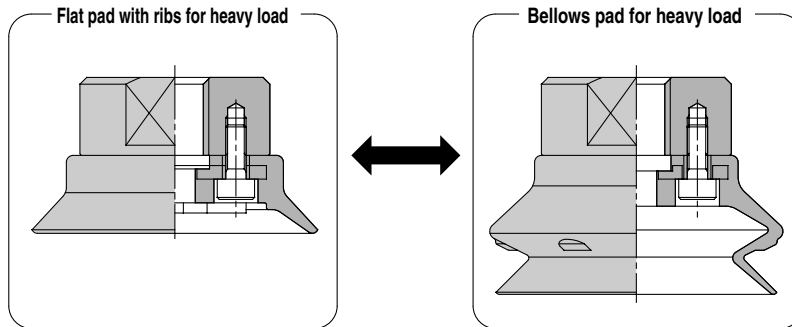

Possible combination — Same pad diameter, $\phi 40$ and $\phi 50$, $\phi 63$ and $\phi 80$, $\phi 100$ and $\phi 125$



Possible adsorption to cylindrical loads with easy fit to the load shape.

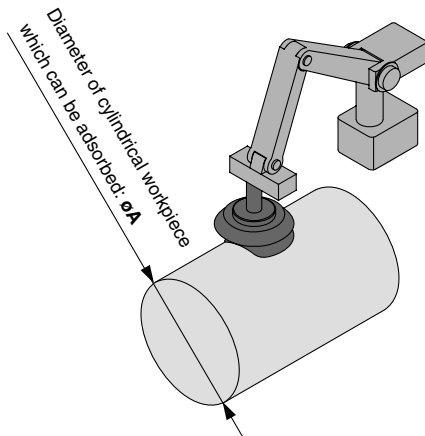

* Pushing force for adsorption is almost equivalent to return force of buffer spring.

Table (1) Diameter of Cylindrical Workpiece Which can be Adsorbed. (Reference value)

Model	Dia. of cylindrical workpiece which can be adsorbed: ϕA ⁽¹⁾
ZP 40HB□	80 or more
50HB□	100 or more
63HB□	120 or more
80HB□	160 or more
100HB□	180 or more
125HB□	230 or more

Note 1) Please consult with SMC when requiring a diameter smaller than shown in table.

Note 2) Regard values mentioned above as reference only, since actual values may depend on operating conditions.



Pad shape permits adsorption to sloped surfaces.

- When a workpiece could be deformed during adsorption or transportation. (Example of a cardboard box)

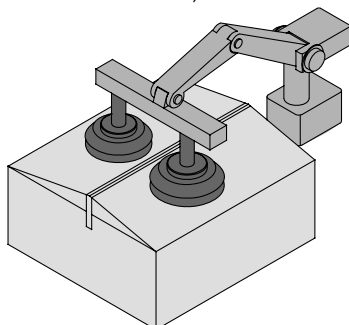

- When the adsorption surface of a workpiece is slanted. (Maximum angle: 5°*)

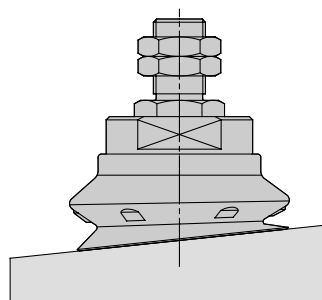

* Regard values mentioned above as reference only, since actual values may depend on operating conditions.

ZA

ZX

ZR

ZM

ZMA

ZQ

ZH

ZU

ZL

ZY□

ZF□

ZP□

SP

ZCUK

AMJ

AMV

AEP

HEP

Related Equipment

Vacuum Pad: Large Size Bellows Type Vertical Vacuum Entry Without Buffer Series ZPT



Specifications

Mounting	Vacuum entry direction		Vertical	
	Connection		Male thread	Female thread
	Thread dia.	ø40, ø50	M14 x 1	M8 x 1.25, M10 x 1.5
		ø63, ø80	M16 x 1.5	M8 x 1.25, M10 x 1.5, M12 x 1.75, M16 x 1.5
	ø100, ø125	M16 x 1.5	M12 x 1.75, M16 x 1.5	
Vacuum entry port		1/8 (Rc, NPT, NPTF)	Use the mounting port	

Pad Type

Pad diameter (mm)	40, 50, 63, 80, 100, 125
Material (Color)	NBR (Black), Silicone rubber (White), Urethane rubber (Brown), Fluororubber (Black with mark ⊕), EPR (Black with mark ⊖)
Durometer	NBR/Silicone rubber/EPR (50°), Urethane/Fluororubber (60°)

Mass

NBR		(g)	
Model	Mass	Model	Mass
ZPT40HBN-A14	73	ZPT 80HBN-A16	195
-B 8	40	-B 8	161
-B10	39	-B10	160
ZPT50HBN-A14	89	-B12	158
-B 8	56	-B16	156
-B10	55	ZPT100HBN-A16	396
ZPT63HBN-A16	155	-B12	347
-B 8	121	-B16	345
-B10	120	ZPT125HBN-A16	580
-B12	118	-B12	531
-B16	116	-B16	529

Mass Difference for Other Materials

Add NBR mass to below table for other materials. (g)

Pad dia.	Silicon rubber	Urethane rubber	Fluoro-rubber	EPR
ø40	-1	+1	+10	0
ø50	-2	+1	+19	0
ø63	-3	+2	+37	0
ø80	-6	+2	+61	0
ø100	-12	+4	+121	-1
ø125	-22	+7	+228	-3

How to Order

ZPT 40 HB N - A14

Pad diameter (mm)

40	40
50	50
63	63
80	80
100	100
125	125

Pad type

HB	Large bellows pad
----	-------------------

Material

N	NBR
S	Silicon rubber
U	Urethane rubber
F	Fluororubber
E	EPR

Mounting thread diameter (Vacuum entry)

Mounting		Symbol	Thread dia. Port size	Pad diameter		
				40, 50	63, 80	100, 125
Male thread	M14 x 1	A14	Rc 1/8	●	—	—
		A14N	NPT 1/8	●	—	—
		A14F	NPFT 1/8	●	—	—
	M16 x 1.5	A16	Rc 1/8	—	●	●
		A16N	NPT 1/8	—	●	●
		A16F	NPFT 1/8	—	●	●
Female thread	B8	M8 x 1.25	●	●	—	
	B10	M10 x 1.5	●	●	—	
	B12	M12 x 1.75	—	●	●	
	B16	M16 x 1.5	—	●	●	

ZPT⁴⁰₅₀HB□-A14 (Male thread)

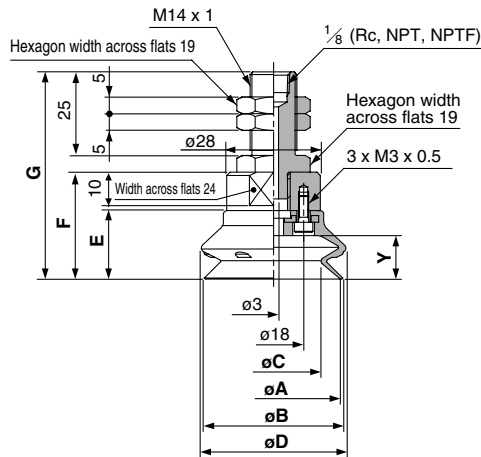

Dimensions

Model	A	B	C	D	E	F	G	Y
ZPT40HB□-A14	40	41	28	43	20.5	32	62	13
ZPT50HB□-A14	50	52	36	54	24	35.5	65.5	16.5

ZPT⁴⁰₅₀HB□-B□ (Female thread)

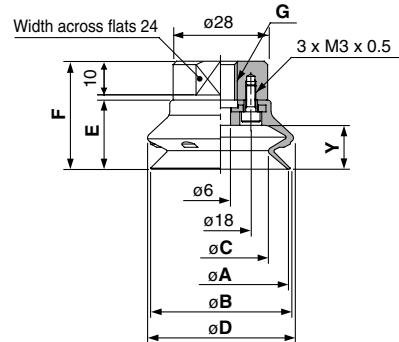

Dimensions

Model	A	B	C	D	E	F	G	Y
ZPT40HB□-B 8	40	41	28	43	20.5	32	M8 x 1.25	13
M10 x 1.5								
ZPT50HB□-B 8	50	52	36	54	24	35.5	M8 x 1.25	16.5
M10 x 1.5								

ZPT⁶³₈₀HB□-A16 (Male thread)

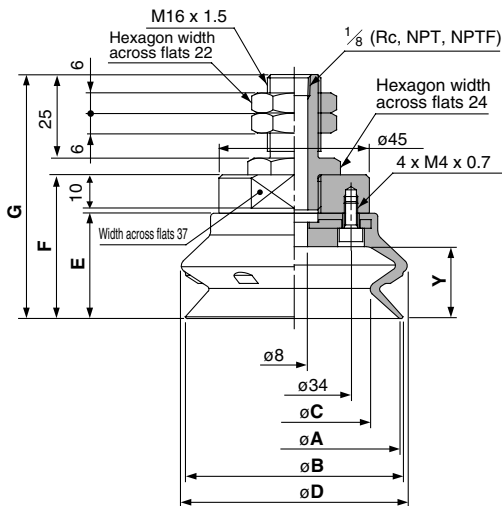

Dimensions

Model	A	B	C	D	E	F	G	Y
ZPT63HB□-A16	63	65	46	68	31.5	43	73	21.5
ZPT80HB□-A16	80	83	58	85	37	48.5	78.5	27.5

ZPT⁶³₈₀HB□-B□ (Female thread)

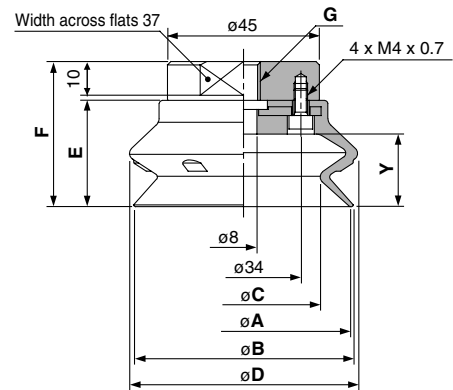

Dimensions

Model	A	B	C	D	E	F	G	Y
ZPT63HB□-B 8	63	65	46	68	31.5	43	M8 x 1.25	21.5
M10 x 1.5								
M12 x 1.75								
M16 x 1.5								
ZPT80HB□-B 8	80	83	58	85	37	48.5	M8 x 1.25	27.5
M10 x 1.5								
M12 x 1.75								
M16 x 1.5								

- ZA
- ZX
- ZR
- ZM
- ZMA
- ZQ
- ZH
- ZU
- ZL
- ZY□
- ZF□
- ZP□
- SP
- ZCUK
- AMJ
- AMV
- AEP
- HEP

Related Equipment

Series ZPT

ZPT¹⁰⁰/₁₂₅HB□-A16 (Male thread)

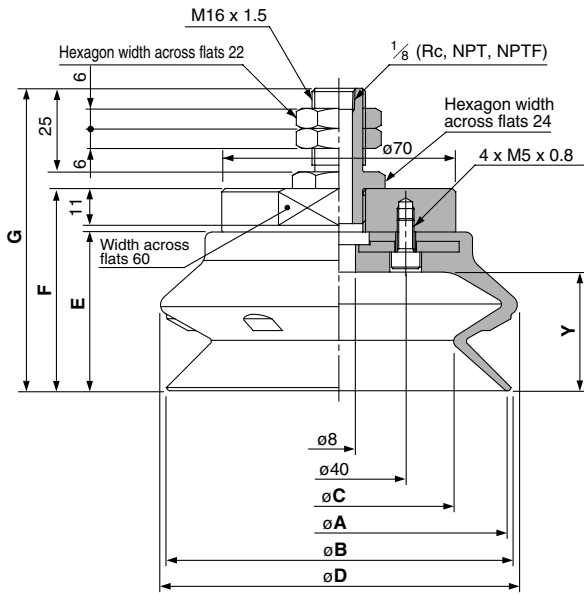

Dimensions

Model	A	B	C	D	E	F	G	Y
ZPT100HB□-A16	100	103	69	107	47.5	60.5	90.5	35.5
ZPT125HB□-A16	125	129	89	135	56	69	99	44

ZPT¹⁰⁰/₁₂₅HB□-B□ (Female thread)

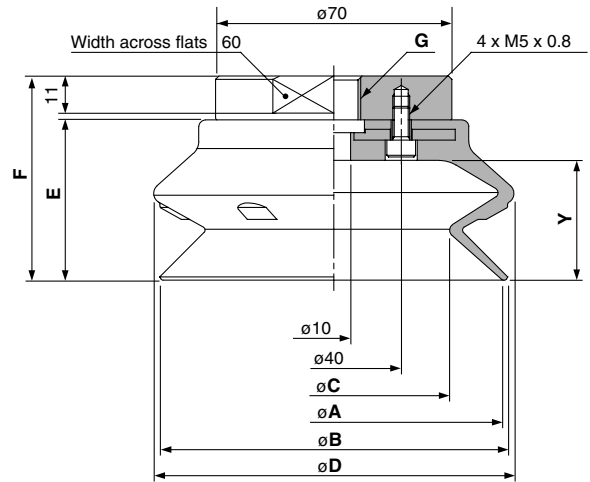

Dimensions

Model	A	B	C	D	E	F	G	Y
ZPT100HB□-B12	100	103	69	107	47.5	60.5	M12 x 1.75	35.5
-B16							M16 x 1.5	
ZPT125HB□-B12	125	129	89	135	56	69	M12 x 1.75	44
-B16							M16 x 1.5	

Vacuum Pad: Large Size Bellows Type Vertical Vacuum Entry With Buffer

Series ZPT



Specifications

Mounting Thread dia.	Vacuum entry direction	Vertical
	Connection	Male thread
	ø40, ø50	M18 x 1.5
	ø63, ø80	M18 x 1.5
	ø100, ø125	M22 x 1.5
Vacuum entry port		1/8 (Rc, NPT, NPTF)

Buffer Specifications

Buffer dia. (mm)	ø40 to ø80		ø100, ø125	
Stroke (mm)	25, 50, 75		25, 50, 75, 100	
Spring reactive force	0 stroke	6.9 N	0 stroke	10 N
	Full stroke	11.8 N	Full stroke	15 N
Non-rotating specification	Rotating (J)			

Pad Type

Pad diameter (mm)	ø40, ø50, ø63, ø80, ø100, ø125
Material (Color)	NBR (Black), Silicone rubber (White), Urethane rubber (Brown), Fluororubber (Black with mark ☉), EPR (Black with mark ☉)
Durometer	NBR/Silicone rubber/EPR (50°), Urethane/Fluororubber (60°)

Mass

NBR		(g)	
Model	Mass	Model	Mass
ZPT40HBNJ25-□01-A18	127	ZPT 80HBNJ50-□01-A18	268
50-□01-A18	147	75-□01-A18	289
75-□01-A18	168	ZPT100HBNJ25-□01-A22	535
ZPT50HBNJ25-□01-A18	143	50-□01-A22	575
50-□01-A18	163	75-□01-A22	620
75-□01-A18	201	100-□01-A22	659
ZPT63HBNJ25-□01-A18	208	ZPT125HBNJ25-□01-A22	719
50-□01-A18	228	50-□01-A22	759
75-□01-A18	249	75-□01-A22	804
ZPT80HBNJ25-□01-A18	231	100-□01-A22	843

Mass Difference for Other Materials

Add NBR mass to below table for other materials. (g)

Pad dia.	Silicon rubber	Urethane rubber	Fluoro-rubber	EPR
ø40	-1	+1	+10	0
ø50	-2	+1	+19	0
ø63	-3	+2	+37	0
ø80	-6	+2	+61	0
ø100	-12	+4	+121	-1
ø125	-22	+7	+228	-3

How to Order

ZPT 40 HB N J 25 - B01 - A18

Pad diameter (mm)

40	ø40
50	ø50
63	ø63
80	ø80
100	ø100
125	ø125

Pad type

HB	Large bellows pad
----	-------------------

Material

N	NBR
S	Silicon rubber
U	Urethane rubber
F	Fluororubber
E	EPR

Vacuum entry

B01	Rc 1/8
N01	NPT 1/8
T01	NPTF 1/8

Buffer stroke (Rotating)

Stroke	ø40	ø50	ø63	ø80	ø100	ø125
25	●	●	●	●	●	●
50	●	●	●	●	●	●
75	●	●	●	●	●	●
100	—	—	—	—	●	●

Mounting thread

A18	M18 x 1.5 (ø40 to ø80)
A22	M22 x 1.5 (ø100, ø125)

Tightening torque (N·m)

Mounting thread dia.	Torque
M18 x 1.5	10.0 ±0.5
M22 x 1.5	10.0 ±0.5

ZA
ZX
ZR
ZM
ZMA
ZQ
ZH
ZU
ZL
ZY□
ZF□
ZP□
SP
ZCUK
AMJ
AMV
AEP
HEP

Related Equipment

Series ZPT

ZPT₅₀⁴⁰HB□J□-B01-A18 (Male thread)

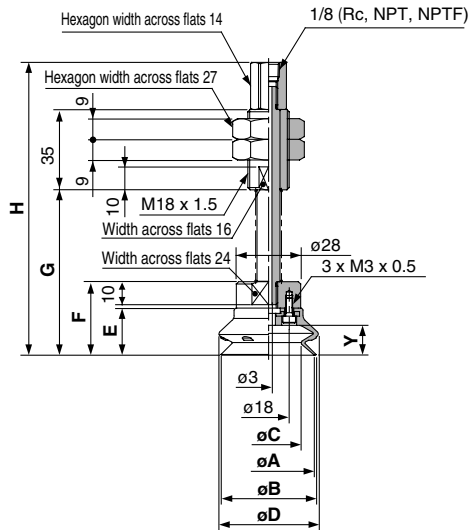

Dimensions

(mm)

Model	A	B	C	D	E	F	G	H	Y
ZPT40HB□J25-□01-A18							72	127.5	
50-□01-A18	40	41	28	43	20.5	32	107	162.5	13
75-□01-A18							143	198.5	
ZPT50HB□J25-□01-A18							75.5	131	
50-□01-A18	50	52	36	54	24	35.5	110.5	166	16.5
75-□01-A18							146.5	202	

ZPT₈₀⁶³HB□J□-B01-A18 (Male thread)

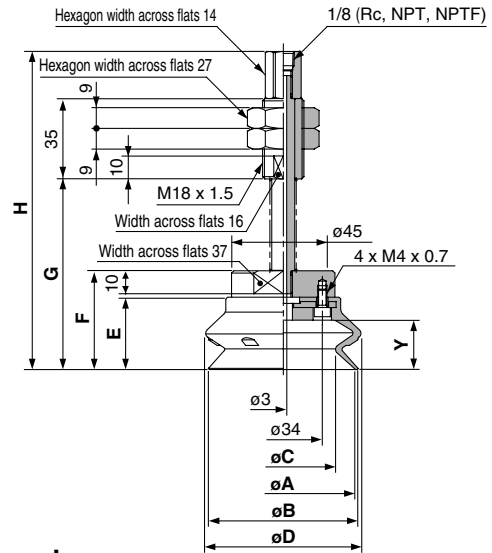

Dimensions

(mm)

Model	A	B	C	D	E	F	G	H	Y
ZPT63HB□J25-□01-A18							83	138.5	
50-□01-A18	63	65	46	68	31.5	43	118	173.5	21.5
75-□01-A18							154	209.5	
ZPT80HB□J25-□01-A18							88.5	144	
50-□01-A18	80	83	58	85	37	48.5	123.5	179	27.5
75-□01-A18							159.5	215	

ZPT₁₂₅¹⁰⁰HB□J□-B01-A22 (Male thread)

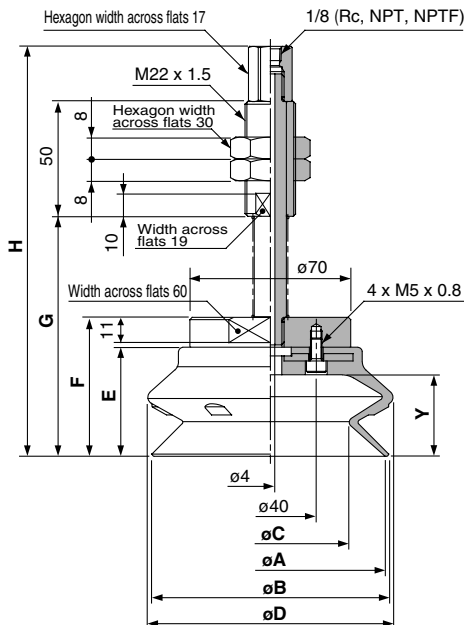

Dimensions

(mm)

Model	A	B	C	D	E	F	G	H	Y
ZPT100HB□J25-□01-A22							104.5	178.5	
50-□01-A22	100	103	69	107	47.5	60.5	140.5	214.5	35.5
75-□01-A22							180.5	254.5	
100-□01-A22							215.5	289.5	
ZPT125HB□J25-□01-A22							113	187	
50-□01-A22	125	129	89	135	56	69	149	223	44
75-□01-A22							189	263	
100-□01-A22							224	298	

Vacuum Pad: Large Size Bellows Type Lateral Vacuum Entry Without Buffer Series ZPX



Specifications

Mounting	Vacuum entry direction	Lateral	
	Connection	Female thread	
	Thread dia.	ø40, ø50	M8 x 1.25, M10 x 1.5
		ø63, ø80	M10 x 1.5, M12 x 1.75
ø100, ø125		M10 x 1.5, M12 x 1.75	
Vacuum entry port		1/8 (Rc, NPT, NPTF)	

Pad Type

Pad diameter (mm)	ø40, ø50, ø63, ø80, ø100, ø125
Material (Color)	NBR (Black), Silicone rubber (White), Urethane rubber (Brown), Fluororubber (Black with mark ☉), EPR (Black with mark ☉)
Durometer	NBR/Silicone rubber/EPR (50°), Urethane/Fluororubber (60°)

Mass

NBR		(g)	
Model	Mass	Model	Mass
ZPX40HBN-□01-B 8	150	ZPX 80HBN-□01-B10	275
-B10	152	-B12	271
ZPX50HBN-□01-B 8	166	ZPX100HBN-□01-B10	464
-B10	164	-B12	460
ZPX63HBN-□01-B10	235	ZPX125HBN-□01-B10	648
-B12	225	-B12	644

Mass Difference for Other Materials

Add NBR mass to below table for other materials.

Pad dia.	Silicon rubber	Urethane rubber	Fluoro-rubber	EPR
ø40	-1	+1	+10	0
ø50	-2	+1	+19	0
ø63	-3	+2	+37	0
ø80	-6	+2	+61	0
ø100	-12	+4	+121	+1
ø125	-22	+7	+228	+3

How to Order

ZPX **40** **HB** **N** - **B01** - **B10**

Pad diameter (mm)

40	40
50	50
63	63
80	80
100	100
125	125

Pad type

HB	Large bellows pad
-----------	-------------------

Mounting thread

		ø40, ø50	ø63, ø80	ø100, ø125
B 8	M8 x 1.25	●	—	—
B10	M10 x 1.5	●	●	●
B12	M12 x 1.75	—	●	●

Vacuum entry

B01	Rc 1/8
N01	NPT 1/8
T01	NPTF 1/8

Material

N	NBR
S	Silicon rubber
U	Urethane rubber
F	Fluororubber
E	EPR

ZA

ZX

ZR

ZM

ZMA

ZQ

ZH

ZU

ZL

ZY□

ZF□

ZP□

SP

ZCUK

AMJ

AMV

AEP

HEP

Related Equipment

Series ZPX

ZPX₄₀⁵⁰HB□-B01-B□ (Female thread)

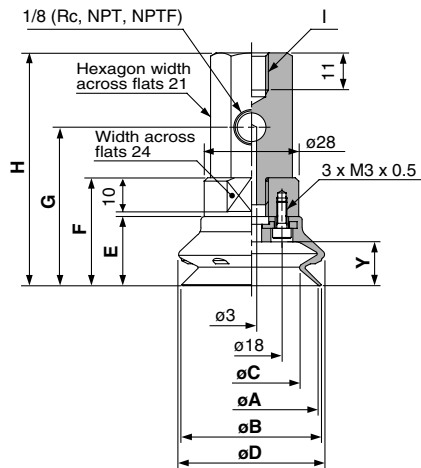

Dimensions (mm)

Model	A	B	C	D	E	F	G	H	I	Y
ZPX40HB□-□01-B 8	40	41	28	43	20.5	32	47	69	M8 x 1.25	13
-B10									M10 x 1.5	
ZPX50HB□-□01-B 8	50	52	36	54	24	35.5	50.5	72.5	M8 x 1.25	16.5
-B10									M10 x 1.5	

ZPX₆₅⁸⁰HB□-B01-B□ (Female thread)

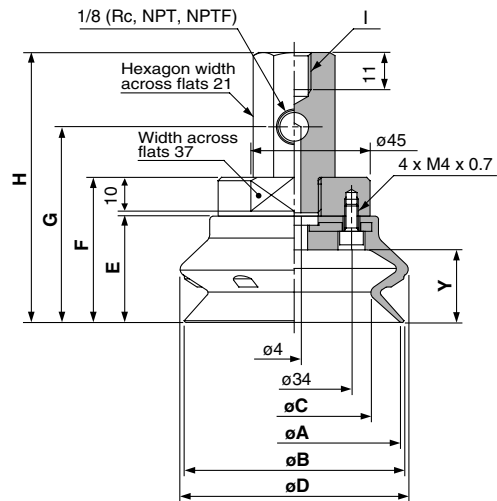

Dimensions (mm)

Model	A	B	C	D	E	F	G	H	I	Y
ZPX63HB□-□01-B10	63	65	46	68	31.5	43	58	80	M10 x 1.5	21.5
-B12									M12 x 1.75	
ZPX80HB□-□01-B10	80	83	58	85	37	48.5	63.5	85.5	M10 x 1.5	27.5
-B12									M12 x 1.75	

ZPX₁₀₀¹²⁵HB□-B01-B□ (Female thread)

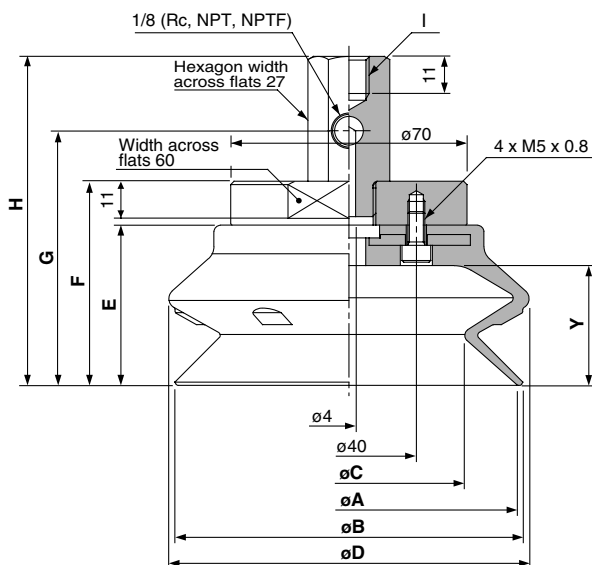

Dimensions (mm)

Model	A	B	C	D	E	F	G	H	I	Y
ZPX100HB□-□01-B10	100	103	69	107	47.5	60.5	75.5	97.5	M10 x 1.5	35.5
-B12									M12 x 1.75	
ZPX125HB□-□01-B10	125	129	89	135	56	69	84	106	M10 x 1.5	44
-B12									M12 x 1.75	

Vacuum Pad: Large Size Bellows Type Lateral Vacuum Entry: With Buffer

Series ZPX



Specifications

Mounting Thread dia.	Vacuum entry direction	Lateral
	Connection	Male thread
	ø40, ø50	M18 x 1.5
	ø63, ø80	M18 x 1.5
	ø100, ø125	M22 x 1.5
Vacuum entry port		1/8 (Rc, NPT, NPTF)

Buffer Specifications

Buffer dia. (mm)	ø40 to ø80		ø100, ø125	
Stroke (mm)	25, 50, 75		25, 50, 75, 100	
Spring reactive force	0 stroke	6.9 N	0 stroke	10 N
	Full stroke	11.8 N	Full stroke	15 N
Non-rotating specification	Rotating (J)			

Pad Type

Pad diameter (mm)	ø40, ø50, ø63, ø80, ø100, ø125
Material (Color)	NBR (Black), Silicone rubber (White), Urethane rubber (Brown), Fluororubber (Black with mark ☉), EPR (Black with mark ☉)
Durometer	NBR/Silicone rubber/EPR (50°), Urethane/Fluororubber (60°)

Mass

NBR		(g)	
Model	Mass	Model	Mass
ZPX40HBNJ25-□01-A18	268	ZPX 80HBNJ50-□01-A18	418
50-□01-A18	289	75-□01-A18	441
75-□01-A18	312	ZPX100HBNJ25-□01-A22	684
ZPX50HBNJ25-□01-A18	284	50-□01-A22	723
50-□01-A18	305	75-□01-A22	767
75-□01-A18	328	100-□01-A22	806
ZPX63HBNJ25-□01-A18	357	ZPX125HBNJ25-□01-A22	868
50-□01-A18	378	50-□01-A22	907
75-□01-A18	401	75-□01-A22	951
ZPX80HBNJ25-□01-A18	397	100-□01-A22	990

Mass Difference for Other Materials

Add NBR mass to below table for other materials.

Pad dia.	Silicon rubber	Urethane rubber	Fluoro-rubber	EPR
ø40	-1	+1	+10	0
ø50	-2	+1	+19	0
ø63	-3	+2	+37	0
ø80	-6	+2	+61	0
ø100	-12	+4	+121	-1
ø125	-22	+7	+228	-3

How to Order

ZPX **40** **HB** **N** **J** **25** - **B01** - **A18**

Pad diameter (mm)

40	40
50	50
63	63
80	80
100	100
125	125

Pad type

HB	Large bellows pad
----	-------------------

Material

N	NBR
S	Silicon rubber
U	Urethane rubber
F	Fluororubber
E	EPR

Vacuum entry

B01	Rc 1/8
N01	NPT 1/8
T01	NPTF 1/8

Buffer stroke (Rotating)

Stroke	ø40	ø50	ø63	ø80	ø100	ø125
25	●	●	●	●	●	●
50	●	●	●	●	●	●
75	●	●	●	●	●	●
100	—	—	—	—	●	●

Mounting thread

A18	M18 x 1.5 (ø40 to ø80)
A22	M22 x 1.5 (ø100, ø125)

Tightening torque (N·m)

Mounting thread dia.	Torque
M18 x 1.5	10.0 ±0.5
M22 x 1.5	10.0 ±0.5

Series ZPX

ZPX₅₀⁴⁰HB□J□-□01-A18 (Male thread)

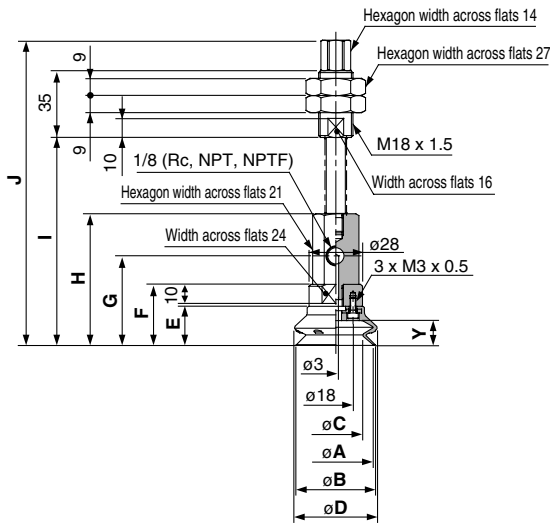

Dimensions (mm)

Model	A	B	C	D	E	F	G	H	I	J	Y
ZPX40HB□J25-□01-A18									109	160	
50-□01-A18	40	41	28	43	20.5	32	47	69	144	195	13
75-□01-A18									180	231	
ZPX50HB□J25-□01-A18									112.5	163.5	
50-□01-A18	50	52	36	54	24	35.5	50.5	72.5	147.5	198.5	16.5
75-□01-A18									183.5	234.5	

ZPX₈₀⁶³HB□J□-□01-A18 (Male thread)

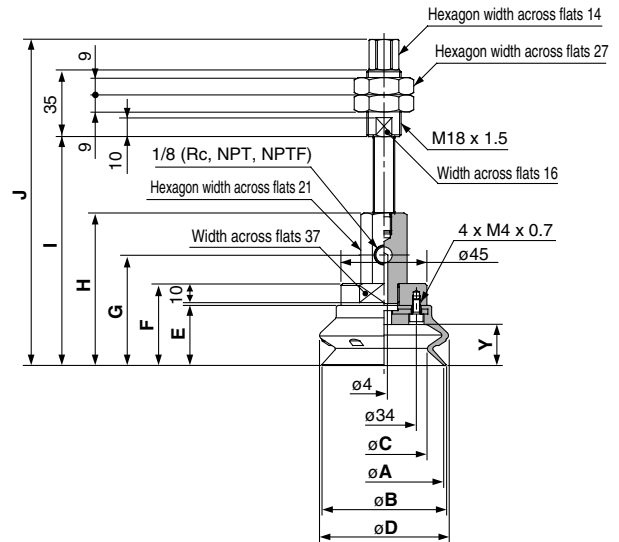

Dimensions (mm)

Model	A	B	C	D	E	F	G	H	I	J	Y
ZPX63HB□J25-□01-A18									120	171	
50-□01-A18	63	65	46	68	31.5	43	58	80	155	206	21.5
75-□01-A18									191	242	
ZPX80HB□J25-□01-A18									125.5	176.5	
50-□01-A18	80	83	58	85	37	48.5	63.5	85.5	160.5	211.5	27.5
75-□01-A18									196.5	247.5	

ZPX₁₂₅¹⁰⁰HB□J□-□01-A22 (Male thread)

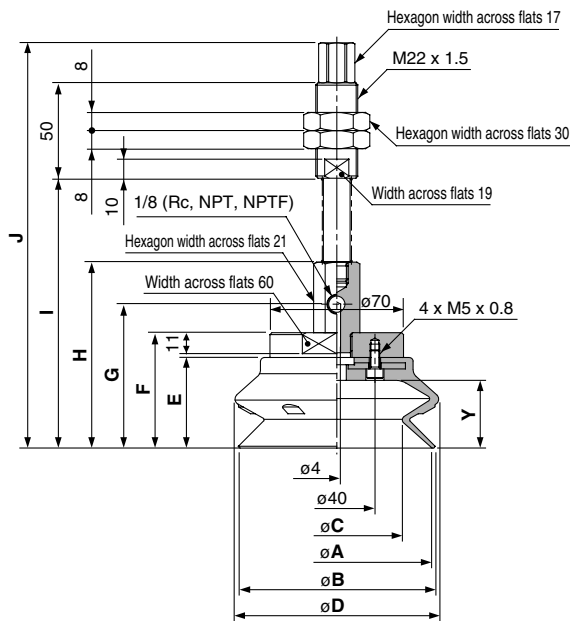

Dimensions (mm)

Model	A	B	C	D	E	F	G	H	I	J	Y
ZPX100HB□J25-□01-A22									141.5	212.5	
50-□01-A22	100	103	69	107	47.5	60.5	75.5	97.5	177.5	248.5	35.5
75-□01-A22									217.5	288.5	
100-□01-A22									252.5	323.5	
ZPX125HB□J25-□01-A22									150	221	
50-□01-A22	125	129	89	135	56	69	84	106	186	257	44
75-□01-A22									226	297	
100-□01-A22									261	332	

Construction

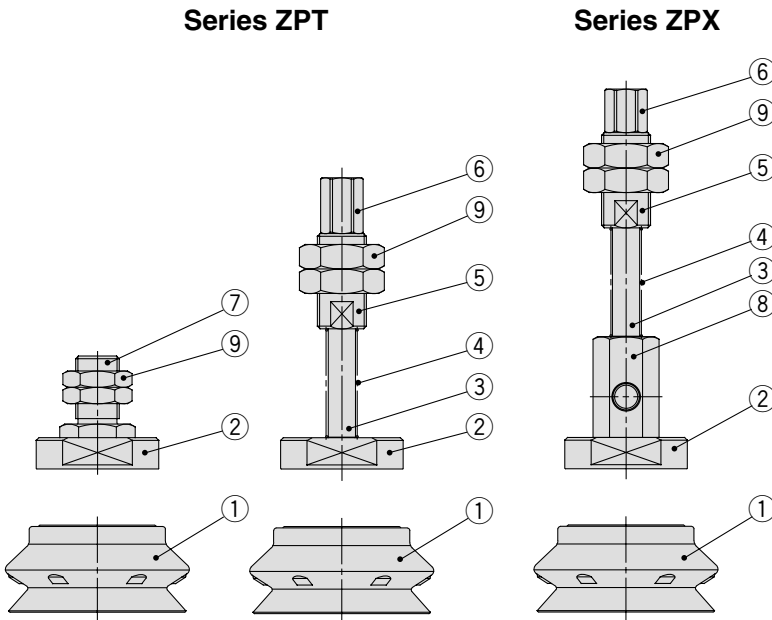

Component Parts

No.	Description	Material	Surface treatment
1	Pad	NBR, Silicone rubber, Urethane rubber, Fluororubber, EPR	—
2	Adapter plate	Aluminum	—
3	Piston rod	Carbon steel	Hard chrome plated
4	Spring	Stainless steel	—
5	Buffer body	Aluminum	—
6	Buffer adapter	Brass	Electroless nickel plated
7	Adapter A	Brass	Electroless nickel plated
8	X type adapter	Brass	Electroless nickel plated
9	Mounting nut	Rolled steel	Nickel plated

Replacement Parts/Pad Unit

How to Order

ZP 40 HB N

Pad diameter (mm)

40	ø40
50	ø50
63	ø63
80	ø80
100	ø100
125	ø125

Material

N	NBR
S	Silicon rubber
U	Urethane rubber
F	Fluororubber
E	EPR

Pad type

HB Large bellows pad

Mass

NBR (g)

Model	Mass
ZP 40HBN	17
ZP 50HBN	33
ZP 63HBN	63
ZP 80HBN	103
ZP100HBN	206
ZP125HBN	390

Mass Difference for Other Materials

Add NBR mass to below table for other materials.

(g)

Pad dia.	Silicon rubber	Urethane rubber	Fluoro-rubber	EPR
ø40	-1	+1	+10	0
ø50	-2	+1	+19	0
ø63	-3	+2	+37	0
ø80	-6	+2	+61	0
ø100	-12	+4	+121	-1
ø125	-22	+7	+228	-3

Dimensions

ZP⁴⁰₅₀40HB□

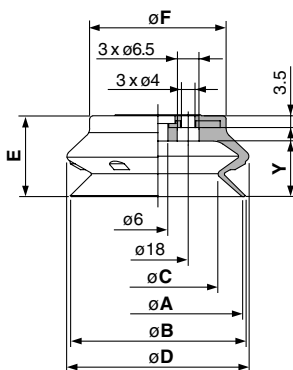

Dimensions (mm)

Model	A	B	C	D	E	F	Y
ZP40HB□	40	41	28	43	20.5	30	13
ZP50HB□	50	52	36	54	24	40.5	16.5

ZP⁶³₈₀63HB□

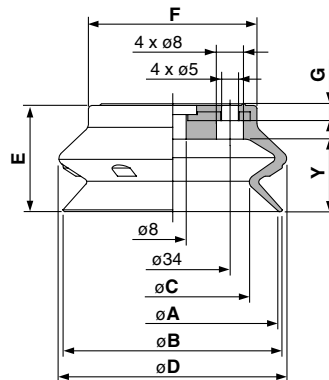

Dimensions (mm)

Model	A	B	C	D	E	F	G	Y
ZP63HB□	63	65	46	68	31.5	50	4.5	21.5
ZP80HB□	80	83	58	85	37	64	5	27.5

ZP¹⁰⁰₁₂₅100HB□

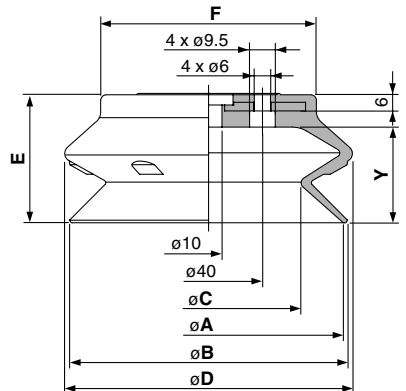

Dimensions (mm)

Model	A	B	C	D	E	F	Y
ZP100HB□	100	103	69	107	47.5	80	35.5
ZP125HB□	125	129	89	135	56	105	44

ZA
ZX
ZR
ZM
ZMA
ZQ
ZH
ZU
ZL
ZY□
ZF□
ZP□
SP
ZCUK
AMJ
AMV
AEP
HEP
Related Equipment

Series ZPT/ZPX

How to Replace the Pad

Remove bolts with a hex. key wrench from the pad underside. Tighten new pad with the bolts ensuring there is no gap between the adapter plate and the pad.

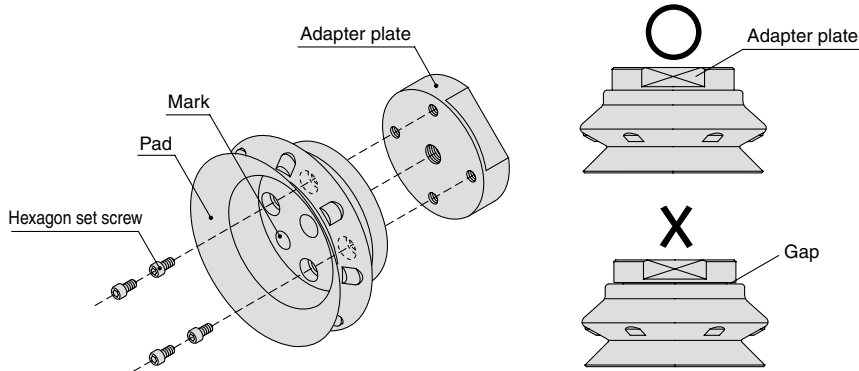

How to Distinguish Different Pad Materials

Check for the indicator mark on the pad's interior surface as shown in the figure at left.

Material	Color	Mark
NBR	Black	—
Silicon rubber	White	—
Urethane rubber	Brown	—
Fluororubber	Black	ⓕ
EPR	Black	ⓔ

Replacement Parts/Mounting Nut

How to Order

ZPNA - M16

● Mounting thread

M14	M14 x 1
M16	M16 x 1.5
M18	M18 x 1.5
M22	M22 x 1.5

Dimensions

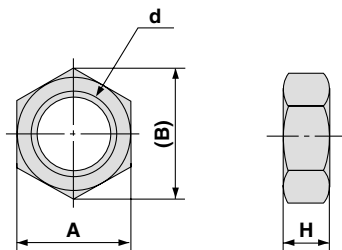

Dimensions

(mm)

Model	A	B	d	H
ZPNA-M14	19	21.9	M14 x 1	5
ZPNA-M16	22	25.4	M16 x 1.5	6
ZPNA-M18	27	31.2	M18 x 1.5	9
ZPNA-M22	30	34.6	M22 x 1.5	8

Bolts (Hexagonal Socket Head Cap Screw)

Dimensions

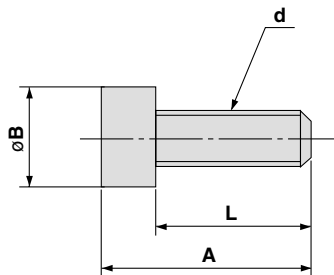

Dimensions

(mm)

A	B	d	L
11	5.5	M3 x 0.5	8
12	7	M4 x 0.7	8
15	8.5	M5 x 0.8	10