

Compact Single Acting Process Pump

Series *PB1000*

Built-in Solenoid Valve Type/Air Operated Type (External Switching Type)



■ A solenoid valve operated pump that fits in the palm of the hand

- 60 x 60 x 41 (mm), 170 g
- Space saving, because piping and wiring is concentrated on one side.

PA
PAP
PAX
PB
PAF
PA□
PB

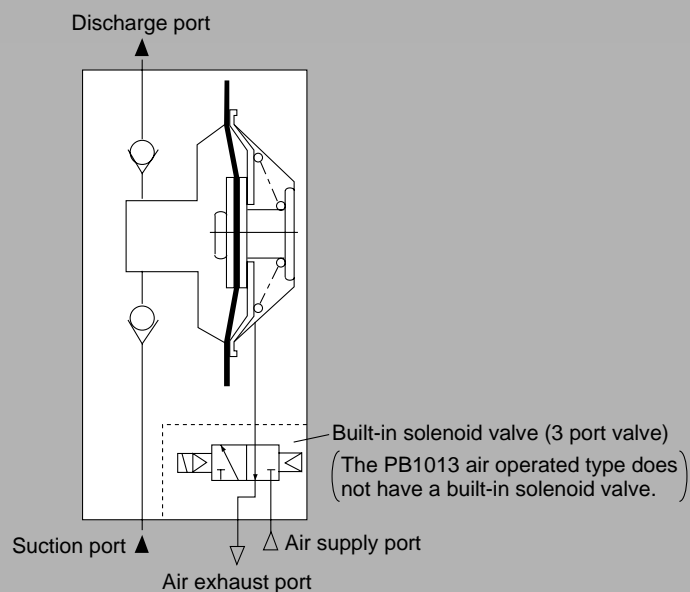

Process Pump Built-in Solenoid Valve Type Air Operated Type (External Switching Type) Series **PB1000**

How to Order



JIS Symbol

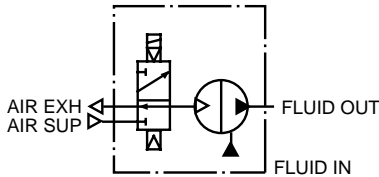

Built-in solenoid valve

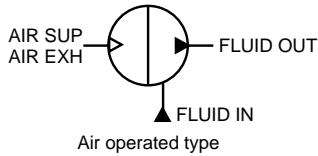

Air operated type

PB1011-01-

Actuation

Symbol	Actuation
1	Built-in solenoid valve
3	Air operated

Thread type

Symbol	Type
Nil	Rc
N	NPT
F	G
T	NPTF

Option

Symbol	Option	Applicable actuation	
		Built-in solenoid valve	Air operated
Nil	None	●	●
B	With foot	●	●
N	With silencer	●	—

* When option is more than one, suffix in alphabetical order.

Port size

Symbol	Port size
01	1/8"



Made to order specifications
(For details, refer to pages 725 and 726)

Wetted part seal SF7000 specification
Wetted part fluororesin specification

Specifications

Model		PB1011	PB1013
Actuation		Built-in solenoid valve	Air operated
Port size	Main fluid suction/discharge port	Rc, NPT, G, NPTF 1/8" Female thread	
	Pilot air	Supply port	Rc, NPT, G, NPTF 1/8" Female thread
		Exhaust port	M5 x 0.8 Female thread
Material	Body wetted areas	Polypropylene PP, Stainless steel (SUS316)	
	Diaphragm	PTFE	
	Check valve	PTFE, PP	
	Liquid contact seals	FKM	
Discharge rate		8 to 2000 mL/min	8 to 500 mL/min
Average discharge pressure		0 to 0.6 MPa	
Pilot air pressure		0.2 to 0.7 MPa	
Air consumption		40 L/min (ANR) or less	
Suction head	Dry	Up to 2.5 m (Interior of pump dry)	
		64 dB (A) or less (Option: with silencer, AN120-M5)	
Withstand pressure		1.05 MPa	
Diaphragm life		20 million times	
Fluid temperature		0 to 50°C (No freezing)	
Ambient temperature		0 to 50°C (No freezing)	
Recommended operating cycle		1 to 10 Hz (0.03 to 1 Hz also possible depending on conditions ^{Note 1)})	
Pilot air solenoid valve recommended Cv factor		—	0.2 ^{Note 2)}
Mass		0.17 kg	0.15 kg
Mounting position		FLUID OUT port at top	
Packaging		General environment	

* Each of the values above are for normal temperatures and when the transferred fluid is fresh water.

* Refer to page 727 for maintenance parts.

* For related products, refer to page 728 and 729.

* Faulty sheets from the check valves or accumulation of dust may cause operation to stop, so slurry processing is not available.

Note 1) After initial suction of liquid operating at 1 to 7 Hz, it can be used with operation at lower cycles. Since a large quantity of liquid will be pumped out, use a suitable throttle in the discharge port if problems occur.

Note 2) With low operating cycles, even a valve with a small Cv factor can be operated.

Performance Curves: Built-in Solenoid Valve Type/Air Operated Type

Cycle (1 Hz)

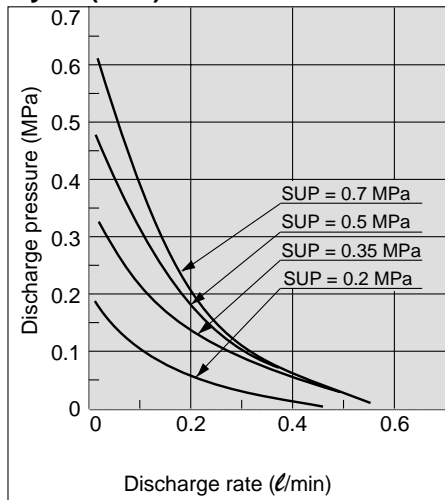

Cycle (5 Hz)

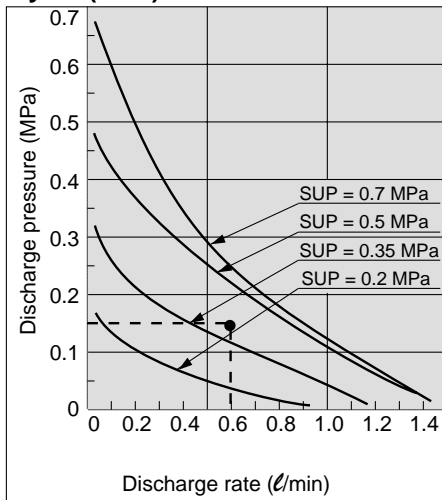

Cycle (10 Hz)

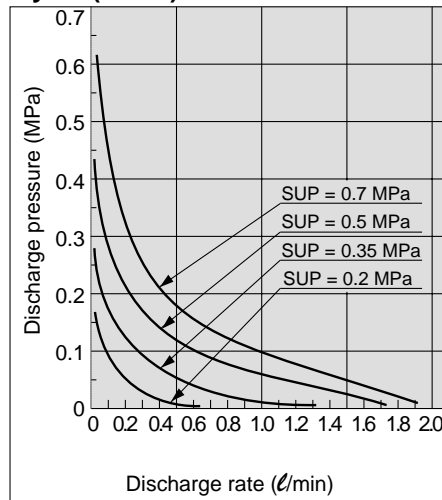

PB1000 Air Consumption

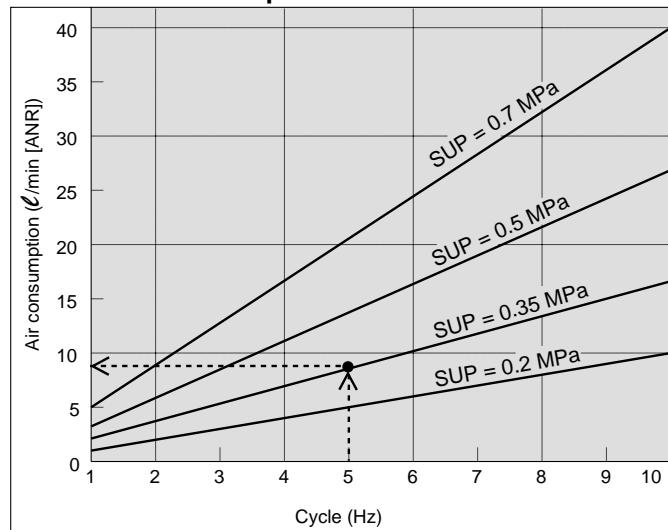

Selection from Flow Characteristic Graph

Required specification example: Find the pilot air pressure and pilot air consumption for a discharge rate of 600 ml/min and a discharge pressure of 0.15 MPa. <The transferred fluid is clean water (viscosity 1 mPa-s, specific gravity 1.0) solenoid valve cycle 5 Hz>

* If the total lifting height is required instead of the discharge pressure, a discharge pressure of 0.1 MPa corresponds to a total lift of 10 m.

Selection procedure:

1. First mark the intersection point for a discharge rate of 600 ml/min and a discharge pressure of 0.15 MPa.
2. Find the pilot air pressure for the marked point. In this case, the point is between the discharge curves for 0.35 MPa and 0.5 MPa, and based on the proportional relationship to these lines, the pilot air pressure for this point is approximately 0.4 MPa.

Calculating Air Consumption

Find the air consumption for operation with a 5 Hz switching cycle and pilot air pressure of 0.35 MPa from the air consumption graph.

Selection procedure

1. Look up from the 5 Hz switching cycle to find the intersection with SUP = 0.35 MPa.
2. From the point just found, draw a line to the Y-axis to find the air consumption. The result is approximately 9 l/min (ANR).

Caution

1. These flow characteristics are for fresh water (viscosity 1 mPa-s, specific gravity 1.0).
2. The discharge rate differs greatly depending on properties (viscosity, specific gravity) of the fluid being transferred and operating conditions (density, lifting range, transfer distance), etc.

Viscosity Characteristics (Flow rate correction for viscous fluids)

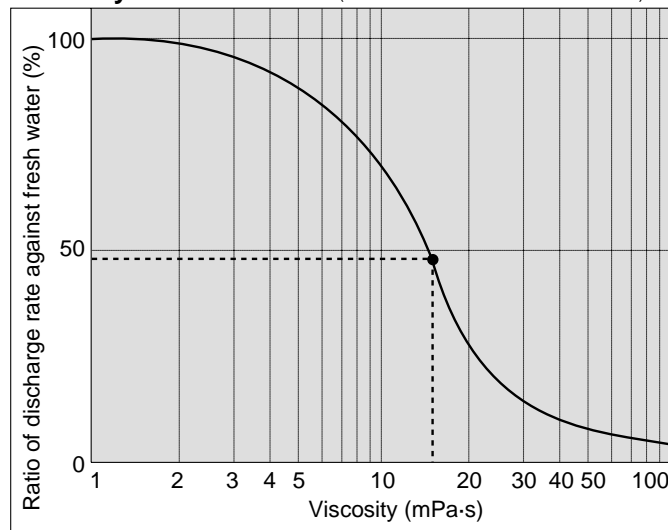

Selection from Viscosity Characteristic Graph

Required specification example:

Find the pilot air pressure and pilot air consumption for a discharge rate of 270 ml/min, and a viscosity of 15 mPa-s.

Selection procedure:

1. First find the ratio of the discharge rate for fresh water when viscosity is 15 mPa-s from the graph to the left. It is determined to be 45%.
2. Next, the viscosity of 15 mPa-s and the discharge rate of 270 l/min in the required specification example are converted to the discharge rate for fresh water. Since 45% of the fresh water discharge rate is equivalent to 270 ml/min in the required specifications, 270 ml/min ÷ 0.45 = approximately 600 ml/min, indicating that a discharge rate of 600 ml/min is required for fresh water.
3. Finally, find the pilot air pressure and pilot air consumption based on viewing of the flow characteristics.

Viscosity: Transfer is possible up to about 100 mPa-s.

Dynamic viscosity ν = Viscosity μ /Density ρ .

$$\nu = \frac{\mu}{\rho}$$

$$\nu(10^{-3}m^2/s) = \mu(mPa-s)/\rho(kg/m^3)$$

- PA
- PAP
- PAX
- PB
- PAF
- PA
- PB

Series PB1000

Working Principle: Built-in Solenoid Valve Type/Air Operated Type

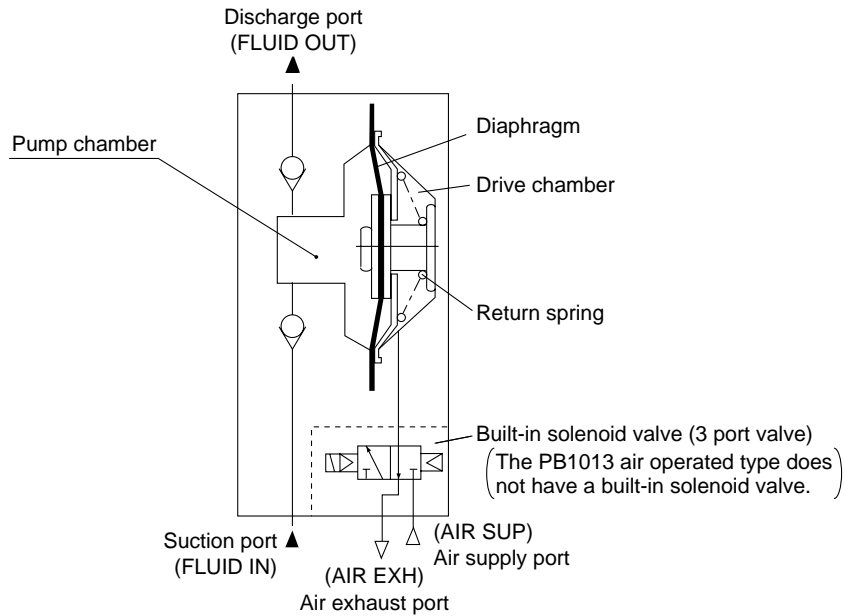

When air is supplied and the built-in solenoid valve is turned ON, air enters the drive chamber and the diaphragm moves to the left. Due to this movement, the fluid in the pump chamber passes through the upper check valve and is discharged to the OUT side. When the solenoid valve is turned OFF, the air inside the drive chamber is evacuated to EXH, and the diaphragm is moved to the right by the return force of the return spring. Due to this movement, the fluid on the FLUID IN side passes through the lower check valve and is sucked into the pump chamber.

The PB1011 repeats this suction and discharge with the repetition of the built-in solenoid valve's ON/OFF operation. The PB1013 air operated type is operated by the ON/OFF operation of an external solenoid valve.

Piping and Operation: Built-in Solenoid Valve Type/Air Operated Type

Piping diagram

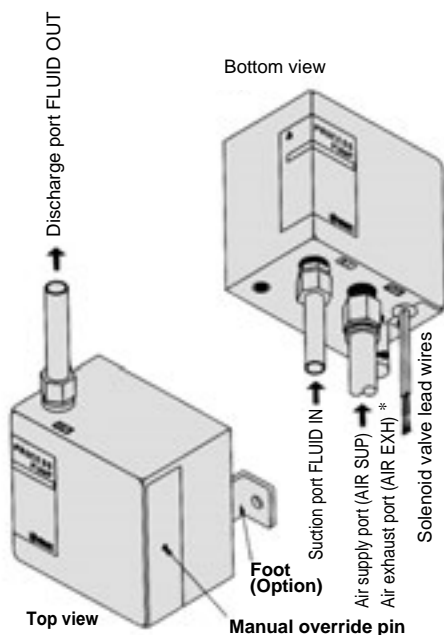

* The PB1013 air operated type has a plug in the air exhaust port <AIR EXH>.

Recommended Valve (Air operated type)

PB1013	SYJ3□4
--------	--------

PA

PAP

PAX

PB

PAF

PA□

PB

⚠ Caution

Be sure that the discharge port <FLUID OUT> is on top when the pump is mounted. Supply clean air that has passed through an AF filter, etc., to the air supply port <AIR SUP>. Air that contains debris or drainage, etc., will have an adverse effect on the built-in solenoid valve, and will cause malfunction of the pump. In cases that particularly require air cleaning, use a filter (Series AF) together with a mist separator (Series AM).

Maintain the proper tightening torque for fittings and mounting bolts, etc.

Looseness can cause problems such as fluid and air leakage, while over tightening can cause damage to threads and parts, etc.

Operation

1. Connect air piping to the air supply port <AIR SUP>, and connect piping for the transfer fluid to the suction port <FLUID IN> and the discharge port <FLUID OUT>.
2. Connect the solenoid valve lead wires to a 24 VDC power supply. Red is (+) and Black is (-). (The PB1013 air operated type must be equipped with a separate solenoid valve.)
3. Using a regulator, set the pilot air pressure within the range of 0.2 to 0.7 MPa. By continuously turning the 24 VDC power ON/OFF the fluid flows from the suction port IN to the discharge port OUT. The pump performs suction with its own power even without priming.
4. To stop the pump turn OFF the 24 VDC power. Also be sure to turn OFF the power when the discharge side is closed. The manual override pin is used for manual operation when there is no electric power. Each time it is pressed, there is one reciprocal operation.

Circuit example/Built-in solenoid valve

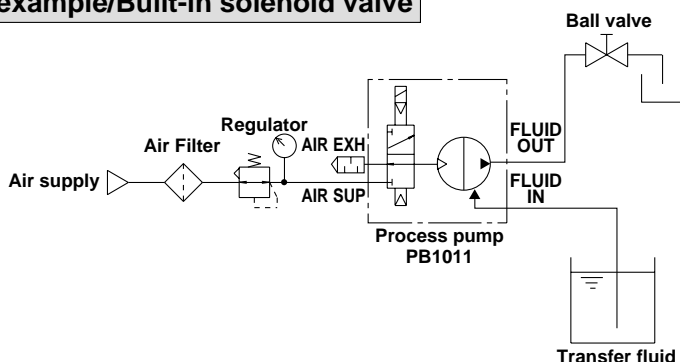

Series PB1000

Dimensions: Built-in Solenoid Valve Type/Air Operated Type

PB1000

