

High Purity Chemical Valve Non-Metallic Exterior

Series LVQ

Clean Wet Series

Constructed without screws

Non-metallic construction without using metal screws to fasten the body of the actuator.

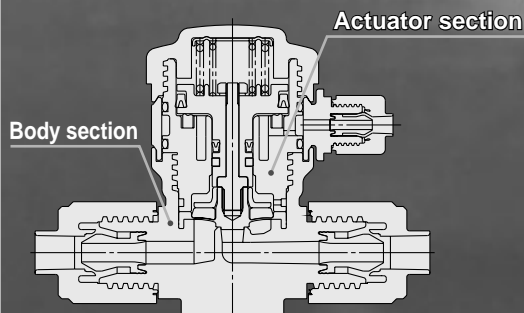

Body: New PFA
 Diaphragm: PTFE
 Actuator section: PVDF

- LVC
- LVA
- LVH
- LVD
- LVQ**
- LQ1
- LVN
- TL/TIL
- LQ3

Integral fitting construction

Hyper fitting/
 Series LQ1, LQ2
 LQ3 is used.

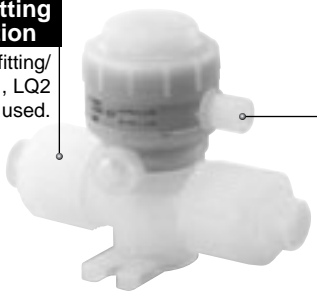

Piping from 8 directions are possible.

Pilot port

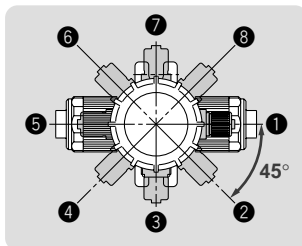

Integral fitting construction

Hyper fitting/Series LQ1, LQ3 is used.
 Can select female thread.

Space Saving Type

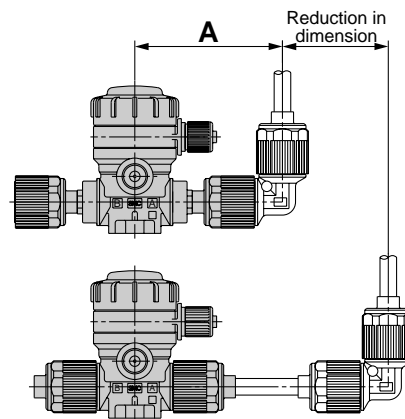

Model	A (mm)	Reduction in dimension (mm)
LVQ20	56.5	40.5 or more
LVQ30	70	49.5 or more
LVQ40	80	61.5 or more
LVQ50	104.5	64.5 or more
LVQ60	114.5	73.5 or more

Piping example

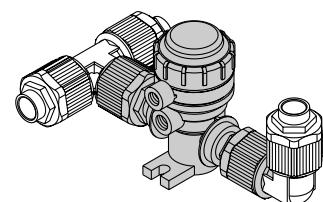

● Integral Fitting and Flare Integral Fitting Types Available

Integral Fitting Type

Series LVQ-V/LVQ-S

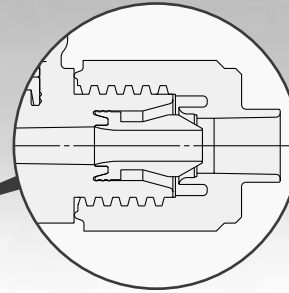
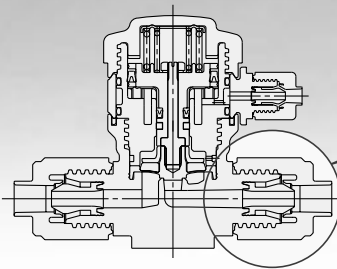

Hyper Fittings
Series LQ1
 (Series LVQ-V)
Series LQ2
 (Series LVQ-S)
 • Insert bushing
 • Quadruple sealing

Flare Integral Fitting Type

Series LVQ-Z

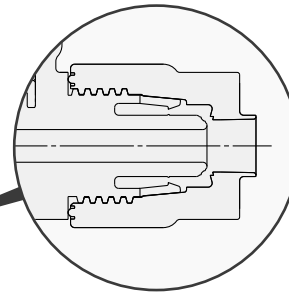
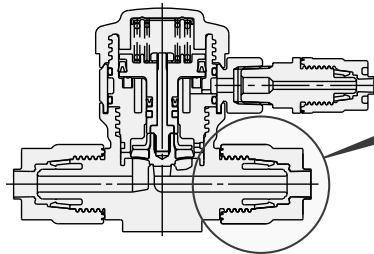

Hyper Fittings
 Flare Type
Series LQ3
 • Flared grip
 • Triple sealing

● Manual Type 2 Types of Handle Operation Selectable

90 Degree Turn Type



- Allows quick switching between valve open/close.

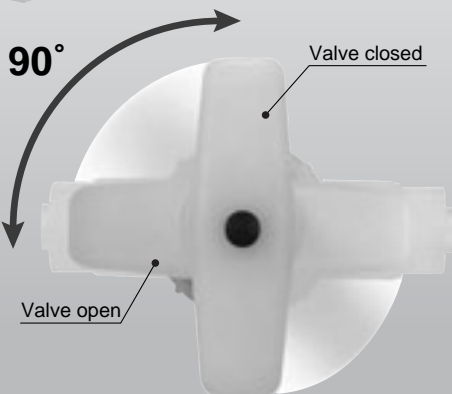

Multi-Turn Type



- Prevents handle from idle turning at the final valve open/closed position and over-twisting.
- Indicator allows visual check of the open/close state of the valve.
- Locknut allows locking at desired open position.

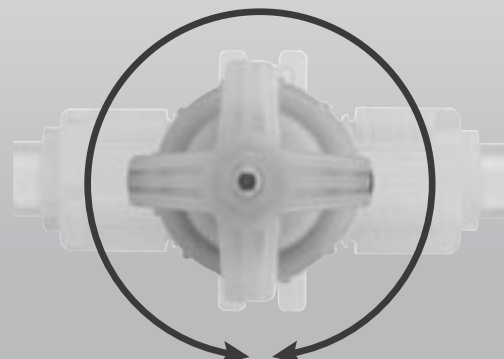



Guide ring

Eliminates lateral motion of the poppet which reduces internal leakage.

Piston damper

Absorbs piston momentum to minimize impact-induced particle generation.

Buffer

Protects diaphragm from deformation and damage due to back pressure.

Integral fittings construction

Offers quadruple seal construction. Nut lock mechanism—no additional tightening required. High flexural strength. Different tubing sizes can be selected.

Diaphragm (PTFE)

Special diaphragm construction ensures gentle opening and closing that prevents the formation of micro-bubbles.

Minimal residual liquid

Residual liquid is minimized by the tapered shape and integral fitting construction, allowing liquid to flow smoothly, achieving improved swept flow characteristics.

Body (New PFA)

Compatible with chemicals such as acids, bases and de-ionized water.

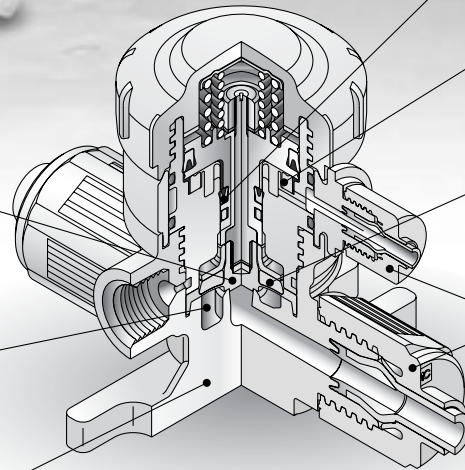

LVC

LVA

LVH

LVD

LVO

LQ1

LVN

TL/TIL

LQ3

Option

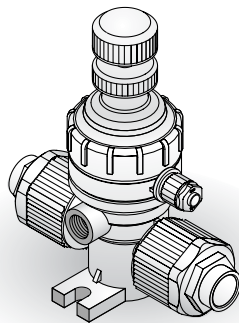

With flow rate adjustment

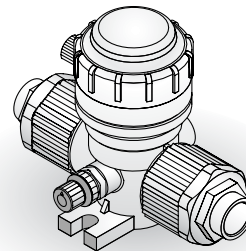

With bypass

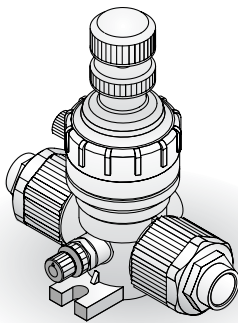

With flow rate adjustment & bypass

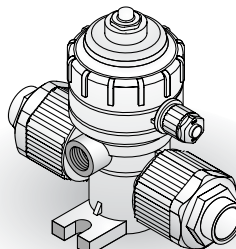

With indicator

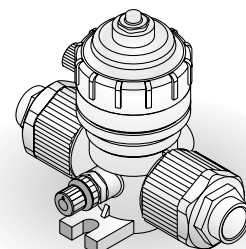

With indicator & bypass

Variations

Integral Fitting Type Series LVQ/LVQH



Orifice dia.	Flow characteristics Av x 10 ⁻⁶ m ² (Cv)	Series	Applicable tubing O.D.																
			Metric sizes						Inch sizes										
			3	4	6	8	10	12	19	25	1/8	3/16	1/4	3/8	1/2	3/4	1		
ø4	8.4 (0.35)	LVQ(H)20	●	●	○								●	●	○				
ø8	31.2 (1.3)	LVQ(H)30			●	●	○							●	○				
ø10	45.6 (1.9)	LVQ(H)40					●	○						●	○				
ø16	120 (5)	LVQ(H)50						●	○					●	○				
ø22	192 (8)	LVQ(H)60							●	○						●	○		

● With reducer ○ Basic size

Integral Fitting Type Space saving/space saving connection Series LVQS/LVQHS

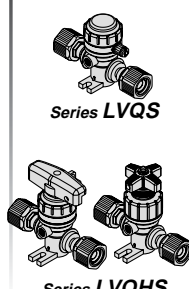

Orifice dia.	Flow characteristics Av x 10 ⁻⁶ m ² (Cv)	Series	Fitting size					
			2	3	4	5	6	
ø4	8.4 (0.35)	LVQ(H)S20	●					
ø8	31.2 (1.3)	LVQ(H)S30		●				
ø10	45.6 (1.9)	LVQ(H)S40			●			
ø16	120 (5)	LVQ(H)S50				●		
ø22	192 (8)	LVQ(H)S60					●	

Flare Integral Fitting Type Series LVQ-Z/LVQH-Z



Orifice dia.	Flow characteristics Av x 10 ⁻⁶ m ² (Cv)	Series	Applicable tubing O.D.																
			Metric sizes						Inch sizes										
			3	4	6	8	10	12	19	25	1/8	3/16	1/4	3/8	1/2	3/4	1		
ø4	8.4 (0.35)	LVQ20(H)-Z	●	●	●									●	●				
ø8	31.2 (1.3)	LVQ30(H)-Z					●								●				
ø10	45.6 (1.9)	LVQ40(H)-Z						●							●				
ø16	120 (5)	LVQ50(H)-Z							●						●				
ø22	192 (8)	LVQ60(H)-Z								●						●			

Flare Integral Fitting Type Space saving/space saving connection Series LVQS-Z/LVQHS-Z

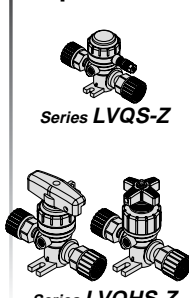

Orifice dia.	Flow characteristics Av x 10 ⁻⁶ m ² (Cv)	Series	Fitting size					
			2	3	4	5	6	
ø4	8.4 (0.35)	LVQ20(H)S-Z	●					
ø8	31.2 (1.3)	LVQ30(H)S-Z		●				
ø10	45.6 (1.9)	LVQ40(H)S-Z			●			
ø16	120 (5)	LVQ50(H)S-Z				●		
ø22	192 (8)	LVQ60(H)S-Z					●	

Tube Extension Fitting Type Series LVQ-T/LVQH-T

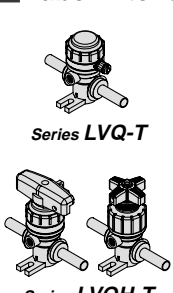

Orifice dia.	Flow characteristics Av x 10 ⁻⁶ m ² (Cv)	Series	Tubing size																
			Metric sizes					Inch sizes											
			6	10	12	19	25	1/4	3/8	1/2	3/4	1							
ø4	8.4 (0.35)	LVQ20(H)-T	●							●									
ø8	31.2 (1.3)	LVQ30(H)-T		●							●								
ø10	45.6 (1.9)	LVQ40(H)-T			●							●							
ø16	120 (5)	LVQ50(H)-T				●							●						
ø22	192 (8)	LVQ60(H)-T					●							●					

LVC

LVA

LVH

LVD

LVQ

LQ1

LVN

TL/TIL

LQ3

INDEX

Integral Fitting Type

Air Operated Type
Integral Fitting Type
Hyper Fittings
● **Series LVQ**

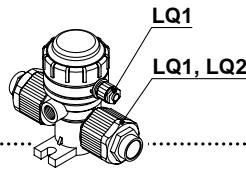

P.518

Air Operated Type
Integral Fitting Type
Space Saving/Space Saving Connection
● **Series LVQS**

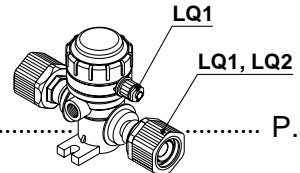

P.526

Manual Type
Integral Fitting Type
Hyper Fittings
● **Series LVQH**

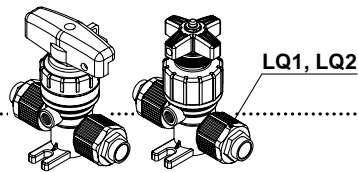

P.535

Manual Type
Integral Fitting Type
Space Saving/Space Saving Connection
● **Series LVQHS**

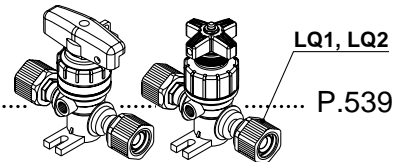

P.539

Fittings and Special Tools

P.544

Flare Integral Fitting Type

Air Operated Type
Flare Integral Fitting Type
Hyper Fittings
● **Series LVQ-Z**

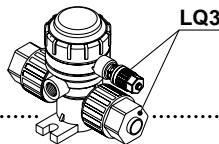

P.545

Air Operated Type
Flare Integral Fitting Type
Space Saving/Space Saving Connection
● **Series LVQS-Z**

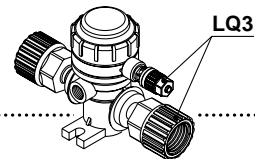

P.553

Manual Type
Flare Integral Fitting Type
Hyper Fittings
● **Series LVQH-Z**

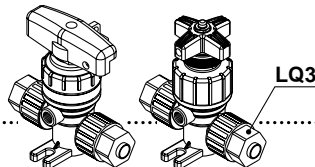

P.562

Manual Type
Flare Integral Fitting Type
Space Saving/Space Saving Connection
● **Series LVQHS-Z**

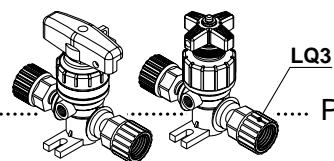

P.566

INDEX

Tube Extension
Fitting Type

Air Operated Type
Tube Extension Fitting Type

● **Series LVQ-T**

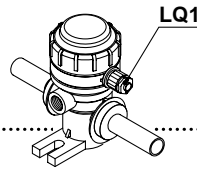

P.571

Manual Type
Tube Extension Fitting Type

● **Series LVQH-T**

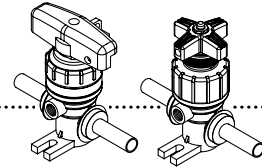

P.578

Integral
Fitting Type

Air Operated Type for Back Pressure 0.5 MPa
Integral Fitting Type
Hyper Fittings

● **Series LVQ□□H**

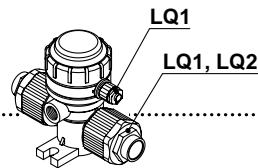

P.581

Flare Integral
Fitting Type

Air Operated Type for Back Pressure 0.5 MPa
Flare Integral Fitting Type
Hyper Fittings

● **Series LVQ□□H-Z**

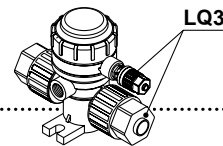

P.582

Applicable Fluids

P.584

High Purity Chemical Valve Non-Metallic Exterior
Specific Product Precautions

P.585, 586

LVC

LVA

LVH

LVD

LVQ

LQ1

LVN

TL/TIL

LQ3

Standard Specifications

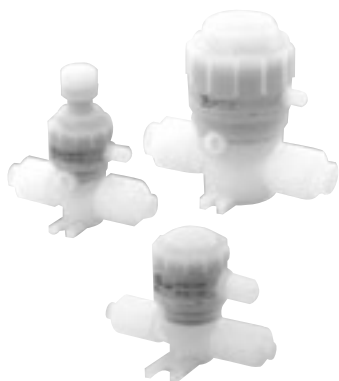

Model		LVQ20	LVQ30	LVQ40	LVQ50	LVQ60
Tubing O.D.	Metric size	6	10	12	19	25
	Inch size	1/4	3/8	1/2	3/4	1
Fitting type	IN/OUT port	LQ1 or LQ2				LQ1
	Pilot port	LQ1				
Orifice diameter		ø4	ø8	ø10	ø16	ø22
Flow characteristics	Av x 10 ⁻⁶ m ²	8.4	31.2	45.6	120	192(228) ^{Note)}
	Cv	0.35	1.3	1.9	5	8(9.5) ^{Note)}
Withstand pressure (MPa)		1				
Operating pressure <A→B flow>	Standard	-98 kPa to 0.5 MPa			-98 kPa to 0.4 MPa	
	High temperature	-98 kPa to 0.3 MPa				
Back pressure (MPa)	Standard	0.3 or less			0.2 or less	
	High back pressure	0.42				
	High temperature	0.3 or less			0.2 or less	
Valve leakage (cm ³ /min)		0 (With water pressure)				
Pilot air pressure (MPa)		0.3 to 0.5 (High back pressure: 0.45 to 0.55)				
Pilot port size		1/8" (ø3), ø4, Rc 1/8, NPT 1/8				
Fluid temperature (°C)	Standard	0 to 100				
	High temperature	0 to 170				
Ambient temperature (°C)		0 to 60				
Mass (kg)		0.08	0.17	0.22	0.70	0.81

Note) () is high flow specification.

Different Diameter Tubing Applicable with Reducer

Different diameter tubing can be selected (within a body class) by using a nut and insert bushing (reducer). ● With reducer

Body class	Tubing O.D.														
	Metric sizes							Inch sizes							
	3	4	6	8	10	12	19	25	1/8	3/16	1/4	3/8	1/2	3/4	1
2	●	●	○	—	—	—	—	—	●	●	○	—	—	—	—
3	—	—	●	●	○	—	—	—	—	—	●	○	—	—	—
4	—	—	—	—	●	○	—	—	—	—	—	●	○	—	—
5	—	—	—	—	—	●	○	—	—	—	—	—	●	○	—
6	—	—	—	—	—	—	●	○	—	—	—	—	—	●	○

🔍 Note) Refer to page 544 for information on changing tubing sizes.

⚠️ Specific Product Precautions

Be sure to read before handling. Refer to front matters 42 and 43 for Safety Instructions, and pages 585 and 586 for High Purity Chemical Valve Non-Metallic Exterior Precautions.

Piping

⚠️ Caution

1. Connect tubing with special tools.

Refer to the pamphlet "High-Purity Fluoropolymer Fittings HYPER FITTING®/Series LQ1, 2 Work Procedure Instructions" (M-E05-1) for connecting tubing and special tools. (Downloadable from our web site.)

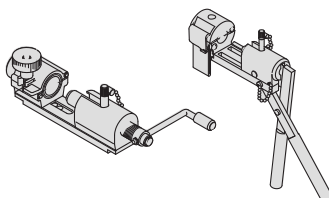

⚠️ Caution

2. Tighten the nut to the end surface of the body. As a guide, refer to the proper tightening torques shown below.

Tightening torque for piping

Body class	Torque (N·m)	
	LQ1	LQ2
2	0.3 to 0.4	1.5 to 2.0
3	0.8 to 1.0	3.0 to 3.5
4	1.0 to 1.2	7.5 to 9.0
5	2.5 to 3.0	11.0 to 13.0
6	5.5 to 6.0	—

Series LVQ

Construction

Basic type

N.C. type

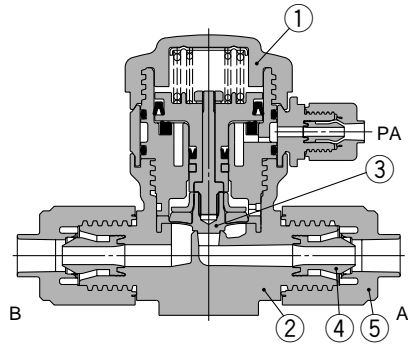

N.O. type

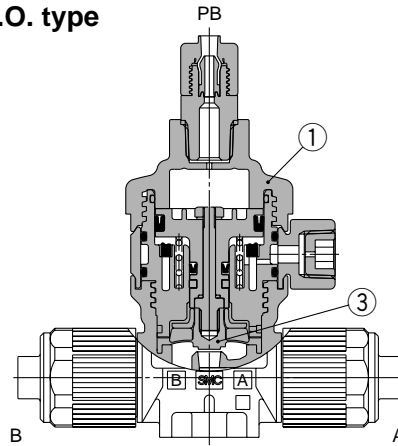

Double acting type

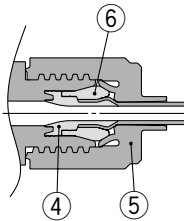
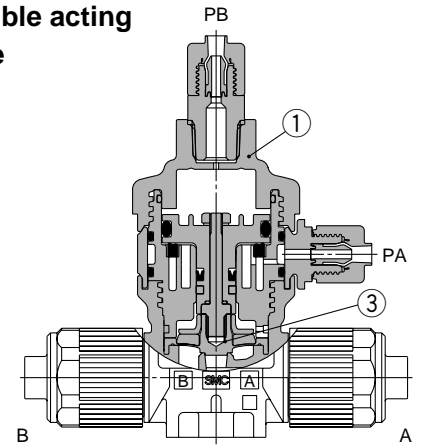

With reducer

With flow rate adjustment

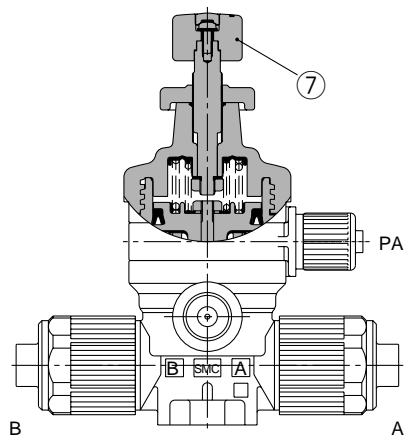

With bypass

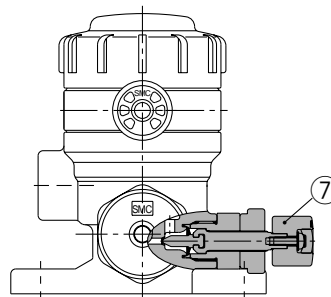

With indicator

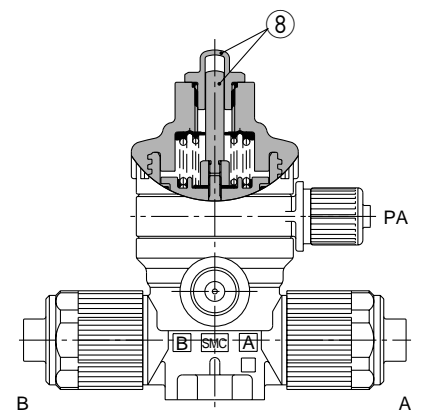

Parts list

No.	Description	Material
1	Actuator section	PVDF
2	Body	PFA
3	Diaphragm	PTFE
4	Insert bushing	PFA
5	Nut	PFA
6	Collar	PFA
7	Flow rate adjuster section	PVDF
8	Indicator, cover	PP

Dimensions

Basic type, High back pressure spec.
N.C. valve

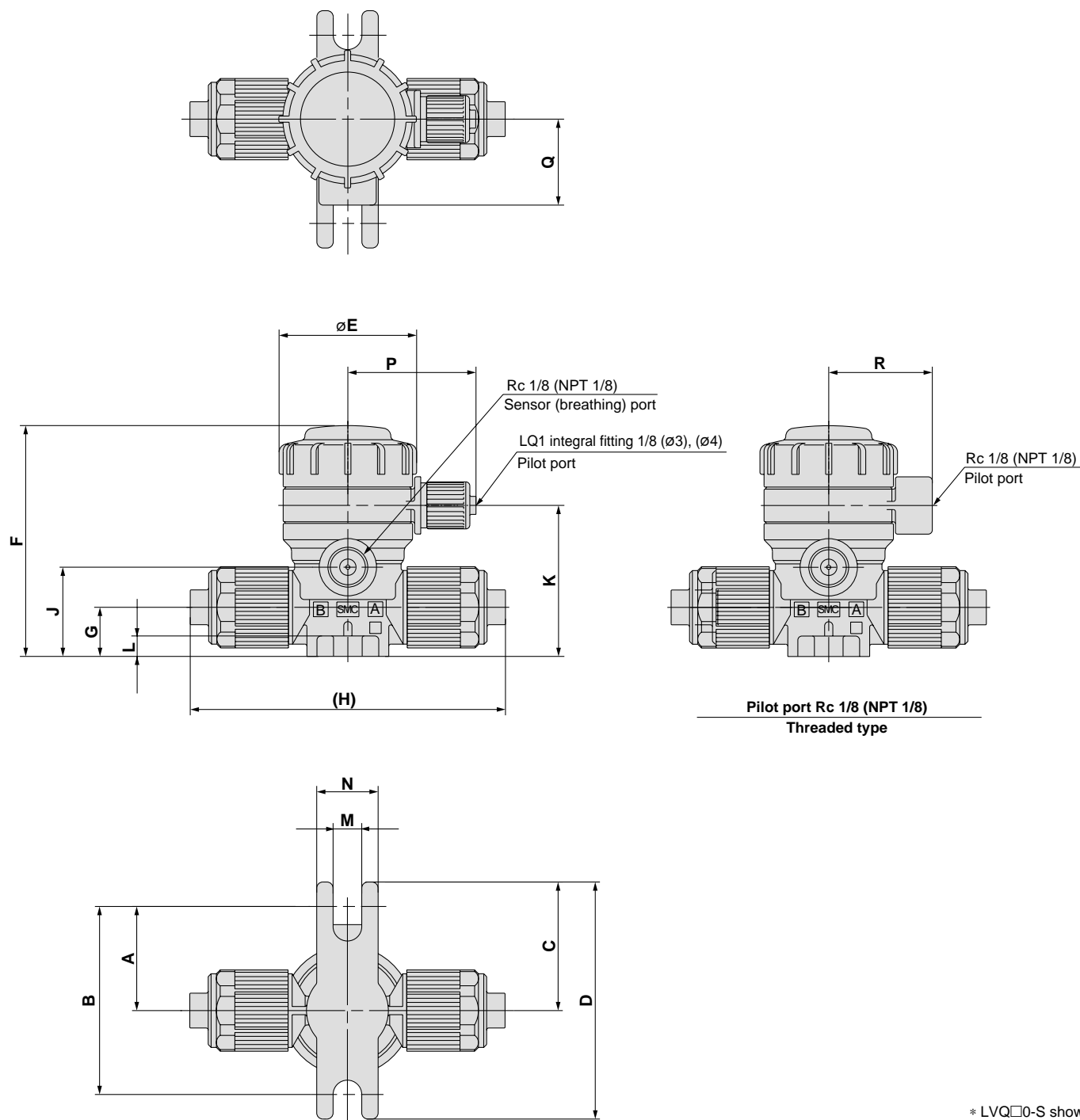

- LVC
- LVA
- LVH
- LVD
- LVQ**
- LQ1
- LVN
- TL/TIL
- LQ3

* LVQ□0-S shown.

LVQ□0- $\frac{V}{S}$ □ Dimensions (N.C. valve)

(mm)

Model	A	B	C	D	E	F	G	H		J	K	L	M	N	P	Q	R
								V□	S□								
LVQ20- $\frac{V}{S}$ □	25.5	46	31.5	58	33.6	56.5	12	70	77	21.8	37	5	7	15	31.3	21	25.3
LVQ30- $\frac{V}{S}$ □	28.5	57	34.5	69	45.4	77	16.5	83	95	32	50	6	7	20	37.2	25	31.2
LVQ40- $\frac{V}{S}$ □	28.5	57	34.5	69	45.4	82.5	22	95	109	37.5	55.5	6	7	20	37.2	25	31.2
LVQ50- $\frac{V}{S}$ □	42	84	48	96	75	127	25	130	141	50.2	78.2	10	7	20	50.8	38.5	45
LVQ60-V□*	42	84	48	96	75	136.8	32	150	—	60	88	10	7	20	50.8	38.5	45

* LVQ60 available only as "V".

Series LVQ

Dimensions

With flow rate adjustment, High back pressure spec. with flow rate adjustment

N.C. valve

Dimensions (mm)	
Model	S
LVQ20- $\frac{V}{S}$ □-1	83
LVQ30- $\frac{V}{S}$ □-1	113.5
LVQ40- $\frac{V}{S}$ □-1	119
LVQ50- $\frac{V}{S}$ □-1	171.5
LVQ60-V□-1*	182.5

* LVQ60 available only as "V".

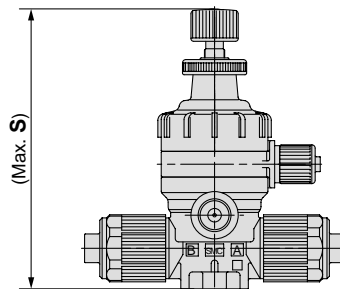

With bypass, High back pressure spec. with bypass

N.C. valve

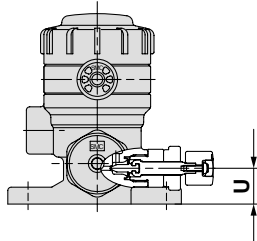
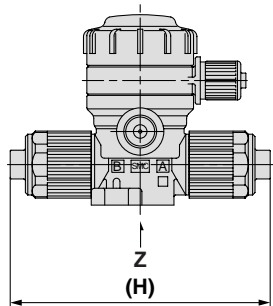
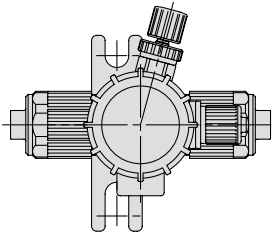

LVQ20

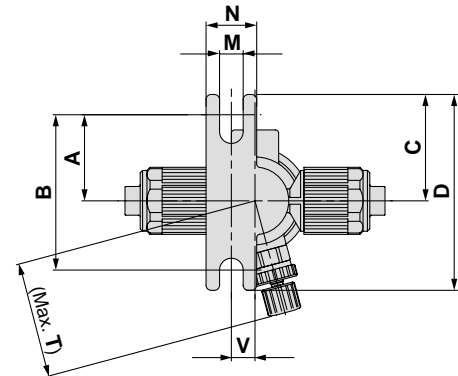

LVQ30, LVQ40
LVQ50, LVQ60

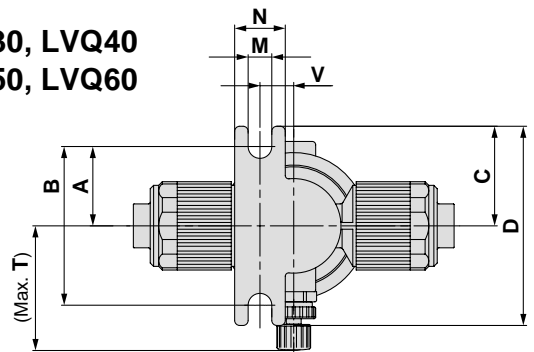

View Z

* LVQ□0-S shown.

Model	A	B	C	D	M	N	T	U	V	H (mm)	
										V□	S□
LVQ20- $\frac{V}{S}$ □-2	25.5	46	31.5	58	7	15	34.3	10.6	7	64	77
LVQ30- $\frac{V}{S}$ □-2	25.5	51	31.5	63	7	15	36.9	16.5	10	83	95
LVQ40- $\frac{V}{S}$ □-2	25.5	51	31.5	63	7	15	37.9	22	10	95	109
LVQ50- $\frac{V}{S}$ □-2	38	76	44	88	7	20	64	25	17	130	141
LVQ60-V□-2*	38	76	44	88	7	20	66	32	17	150	—

* LVQ60 available only as "V".

With flow rate adjustment & bypass
High back pressure spec. with flow rate adjustment & bypass
N.C. valve

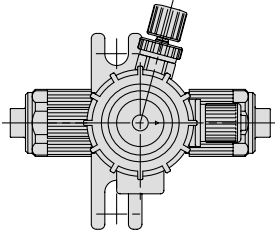

LVQ20

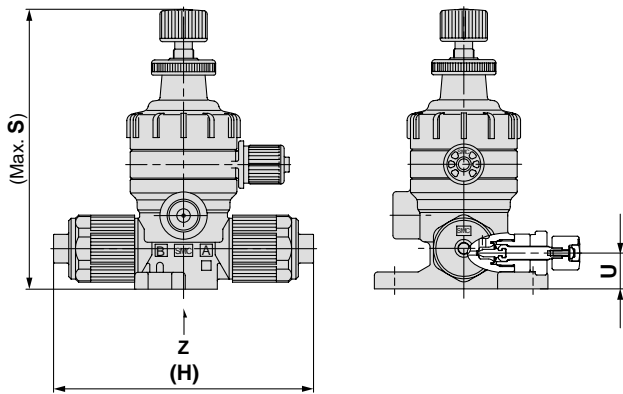
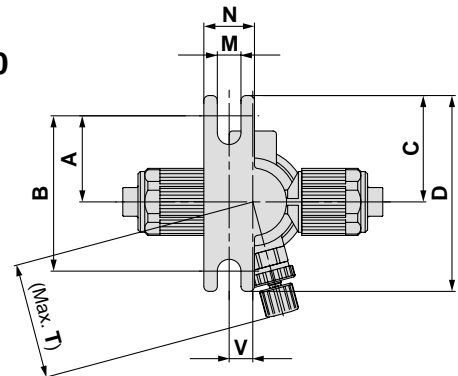

LVQ30, LVQ40
LVQ50, LVQ60

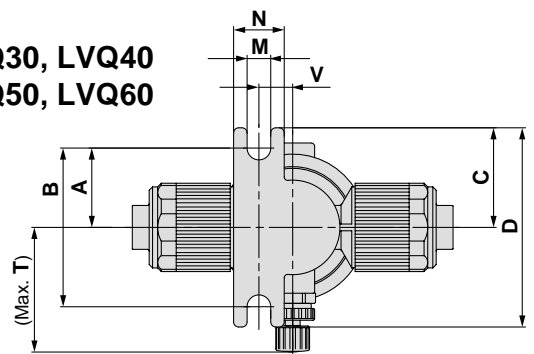

View Z

LVC

LVA

L VH

LVD

LVQ

LQ1

LVN

TL/TIL

LQ3

* LVQ□0-S shown.

Dimensions

(mm)

Model	A	B	C	D	M	N	S	T	U	V	H	
											V□	S□
LVQ20- $\frac{1}{8}$ □-3	25.5	46	31.5	58	7	15	83	34.3	10.6	7	64	77
LVQ30- $\frac{1}{8}$ □-3	25.5	51	31.5	63	7	15	113.5	36.9	16.5	10	83	95
LVQ40- $\frac{1}{8}$ □-3	25.5	51	31.5	63	7	15	119	37.9	22	10	95	109
LVQ50- $\frac{1}{8}$ □-3	38	76	44	88	7	20	171.5	64	25	17	130	141
LVQ60-V□-3*	38	76	44	88	7	20	182.5	66	32	17	150	-

* LVQ60 available only as "V".

With indicator, High back pressure spec. with indicator
N.C. valve

Dimensions

(mm)

Model	S
LVQ20- $\frac{1}{8}$ □-4	70.5
LVQ30- $\frac{1}{8}$ □-4	88.5
LVQ40- $\frac{1}{8}$ □-4	94
LVQ50- $\frac{1}{8}$ □-4	134.5
LVQ60-V□-4*	144

* LVQ60 available only as "V".

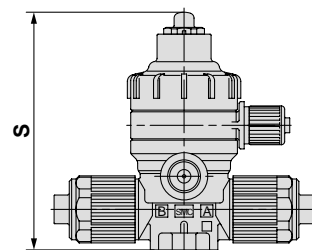

* LVQ□0-S shown.

Series LVQ

Dimensions

Basic type N.O. valve

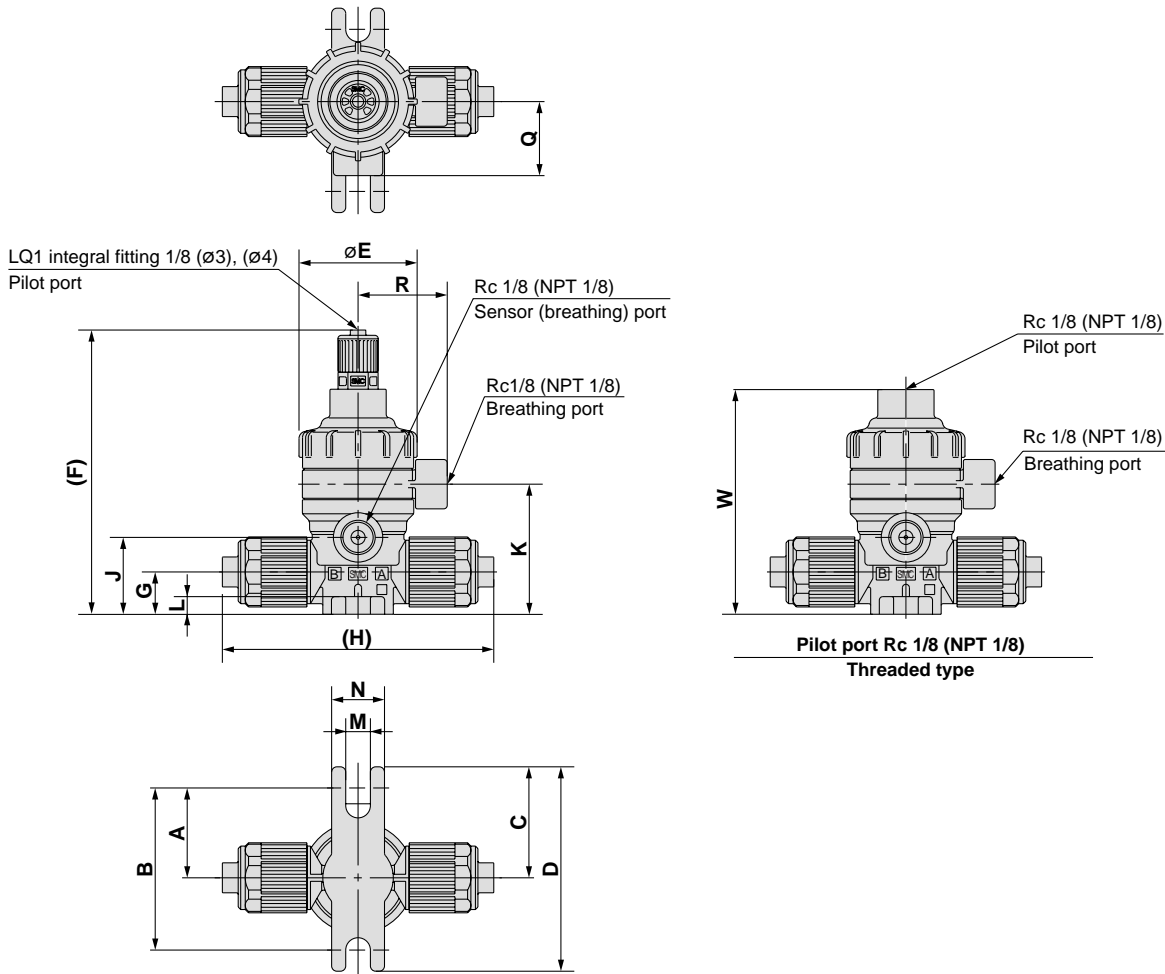

* LVQ□0-S shown.

Double acting valve

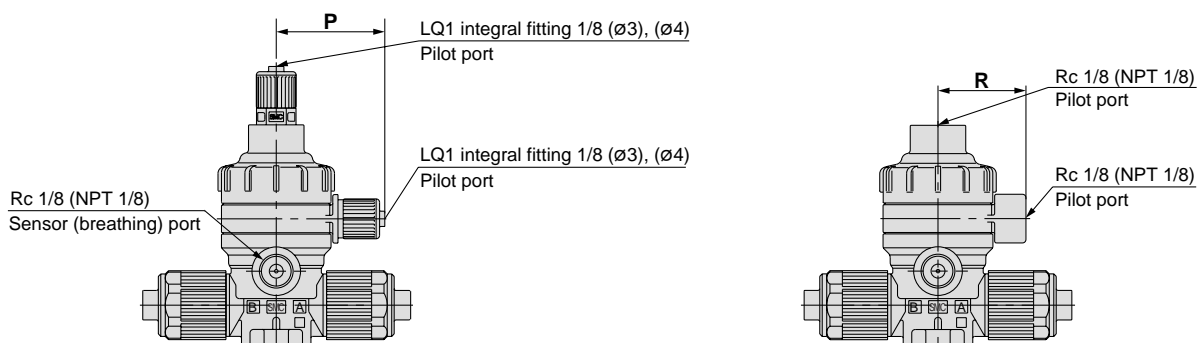

* LVQ□0-S shown.

LVQ□₂¹-V□_s□ Dimensions (N.O. valve, double acting valve)

(mm)

Model	A	B	C	D	E	F	G	H		J	K	L	M	N	P	Q	R	W
								V□	S□									
LVQ2 ₂ ¹ -V□ _s □	25.5	46	31.5	58	33.6	81	12	70	77	21.8	37	5	7	15	31.3	21	25.3	64
LVQ3 ₂ ¹ -V□ _s □	28.5	57	34.5	69	45.4	99	16.5	83	95	32	50	6	7	20	37.2	25	31.2	82
LVQ4 ₂ ¹ -V□ _s □	28.5	57	34.5	69	45.4	104.5	22	95	109	37.5	55.5	6	7	20	37.2	25	31.2	87.5
LVQ5 ₂ ¹ -V□ _s □	42	84	48	96	75	145	25	130	141	50.2	78.2	10	7	20	50.8	38.5	45	128
LVQ6 ₂ ¹ -V□ _s □*	42	84	48	96	75	154.5	32	150	—	60	88	10	7	20	50.8	38.5	45	137.5

* LVQ60 available only as "V".

With bypass
Double acting valve

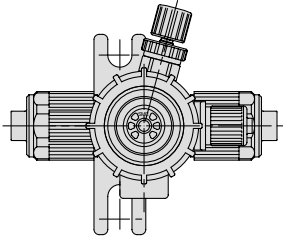

LVQ2_{1/2}

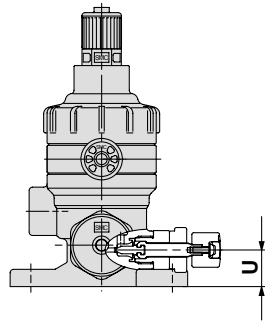
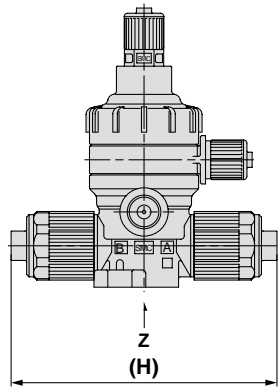
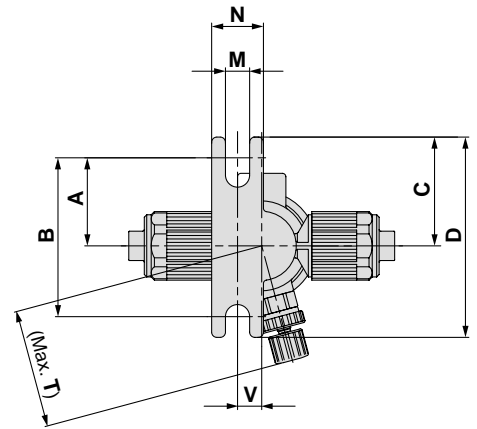

LVQ3_{1/2}, LVQ4_{1/2}
LVQ5_{1/2}, LVQ6_{1/2}

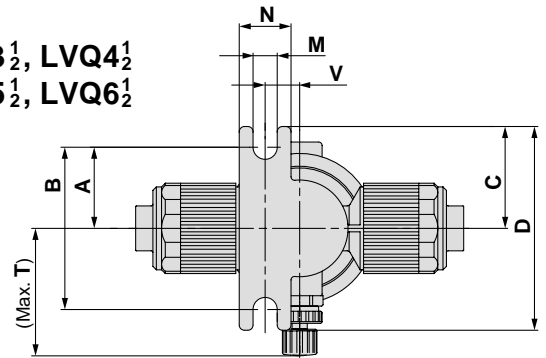

View Z

LVC

LVA

LVH

LVD

LVQ

LQ1

LVN

TL/TIL

LQ3

* LVQ□0-S shown.

Dimensions (N.O valve, double acting valve)

(mm)

Model	A	B	C	D	M	N	T	U	V	H	
										V□	S□
LVQ2 _{1/2} ¹ -V□-2	25.5	46	31.5	58	7	15	34.3	10.6	7	64	77
LVQ3 _{1/2} ¹ -V□-2	25.5	51	31.5	63	7	15	36.9	16.5	10	83	95
LVQ4 _{1/2} ¹ -V□-2	25.5	51	31.5	63	7	15	37.9	22	10	95	109
LVQ5 _{1/2} ¹ -V□-2	38	76	44	88	7	20	64	25	17	130	141
LVQ6 _{1/2} ¹ -V□-2*	38	76	44	88	7	20	66	32	17	150	—

* LVQ60 available only as "V".

Air Operated Type Integral Fitting Type Space Saving/Space Saving Connection Series **LVQS**

How to Order

LVQ **2** **0** **S** - **S** **07** - - - **Option (2)**

Body class

Symbol	Body class	Orifice dia.
2	2	ø4
3	3	ø8
4	4	ø10
5	5	ø16
6	6	ø22

Valve type

0	N.C.
1	N.O.
2	Double acting

Note) Refer to variations in the table below for valve type combinations.

Body type

S	Space saving connection
---	-------------------------

Fitting type

Symbol	Fittings	Body class
V	LQ1	2, 3, 4, 5, 6
S	LQ2	2, 3, 4, 5

Applicable fitting size

Symbol	Fitting size	Body class					
		2	3	4	5	6	
07	2	○					
11	3		○				
13	4			○			
19	5				○		
25	6					○	

Note) Refer to page 527 for How to order fitting parts. Select the fittings of the same size as the one at the valve side.

Pilot port thread type

Nil	LQ1 integral fitting	Connection tubing O.D. 1/8" (ø3)
M	LQ1 integral fitting	Connection tubing O.D. ø4
R	Threaded	Rc 1/8
N	Threaded	NP T1/8

Symbol	Applicable option										Note	
	1	2	3	4	5	6	7	8	9	24		
Nil	○	○	○	○	○	○	○	○	○	○	—	—
J	○	—	—	—	○	○	—	—	—	—	—	For high temperature
K	○	○	○	○	○	○	○	○	○	○	○	Buffer material FFKM
N	○	○	○	○	○	○	○	○	○	○	○	For ammonium hydroxide
P	—	—	—	○	○	—	—	—	—	—	—	High flow spec. LVQ6□ only





Note) Options (2) cannot be combined with each other.

Option (1)

Nil	None	6	High back pressure with flow rate adjustment
1	With flow rate adjustment	7	High back pressure with bypass
2	With bypass	8	High back pressure with flow rate adjustment & bypass
3	With flow rate adjustment & bypass	9	High back pressure with indicator
4	With indicator	24	With indicator & bypass
5	High back pressure (0.42 MPa)		

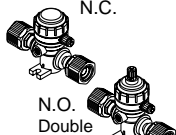
Note) Refer to variations in the table below for valve type and option (1) combinations. Options (1) can not be combined each other.

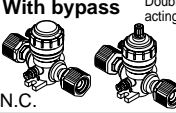
Variations

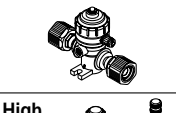
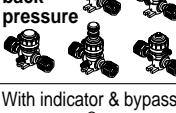
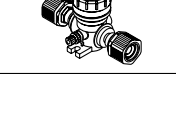
Type	Symbol	Model	LVQ20	LVQ30	LVQ40	LVQ50	LVQ60	
			Orifice diameter Applicable fitting size	ø4	ø8	ø10	ø16	ø22
Basic type N.C. 	N.C.	N.C.	2	3	4	5	6	
			N.O.	○	○	○	○	○
			Double acting	○	○	○	○	○
With flow rate adjustment 	N.C.	N.C.	○	○	○	○	○	
			Double acting	○	○	○	○	○
With bypass 	N.C.	N.C.	○	○	○	○	○	
			Double acting	○	○	○	○	○
With flow rate adjustment & bypass 	N.C.	N.C.	○	○	○	○	○	
			Double acting	○	○	○	○	○
With indicator 	N.C.	N.C.	○	○	○	○	○	
			Double acting	○	○	○	○	○
High back pressure 	N.C.	N.C.	○	○	○	○	○	
			Double acting	○	○	○	○	○
With indicator & bypass 	N.C.	N.C.	○	○	○	○	○	
			Double acting	○	○	○	○	○

How to Order Fittings for Space Saving

Applicable tubing size

Size	No.	Applicable tubing size (mm)	Reducing
2	1	6 x 4	○
2	2	4 x 3	●
3	1	10 x 8	○
3	2	8 x 6	●
3	3	6 x 4	●
4	1	12 x 10	○
4	2	10 x 8	●
5	1	19 x 16	○
5	2	12 x 10	●
6	1	25 x 22	○
6	2	19 x 16	●

Size	Symbol	Applicable tubing size (inch)	Reducing
2	A	1/4" x 5/32"	○
2	B	3/16" x 1/8"	●
2	C	1/8" x 0.086"	●
3	A	3/8" x 1/4"	○
3	B	1/4" x 5/32"	●
4	A	1/2" x 3/8"	○
4	B	3/8" x 1/4"	●
5	A	3/4" x 5/8"	○
5	B	1/2" x 3/8"	●
6	A	1" x 7/8"	○
6	B	3/4" x 5/8"	●



○ Basic size ● With reducer

Note 1) Select a fitting the same size as the valve fitting.

LQ1 E 61 - S
LQ2 E 21 - S

One nut (including insert bushing) of the nuts is not attached.

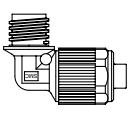
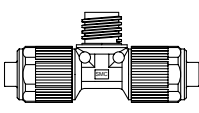
Type of fitting

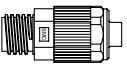
E	T
Union elbow 	Union tee 
P	U
Panel mount union 	Union 

Applicable tubing size

Size	No.	Applicable tubing size (mm)	Reducing
2	1	6 x 4	○
2	2	4 x 3	●
3	1	10 x 8	○
3	2	8 x 6	●
3	3	6 x 4	●
4	1	12 x 10	○
4	2	10 x 8	●
5	1	19 x 16	○
5	2	12 x 10	●

Size	Symbol	Applicable tubing size (inch)	Reducing
2	A	1/4" x 5/32"	○
2	B	3/16" x 1/8"	●
2	C	1/8" x 0.086"	●
3	A	3/8" x 1/4"	○
3	B	1/4" x 5/32"	●
4	A	1/2" x 3/8"	○
4	B	3/8" x 1/4"	●
5	A	3/4" x 5/8"	○
5	B	1/2" x 3/8"	●

○ Basic size ● With reducer

Note 1) Select a fitting the same size as the valve fitting.

Piping example

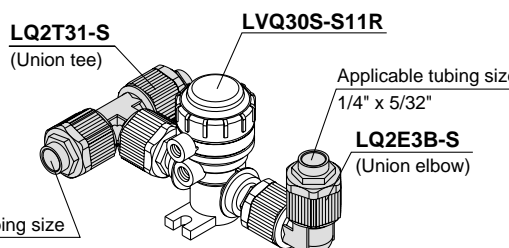

LQ2T31-S (Union tee)

LVQ30S-S11R

Applicable tubing size 10 x 8

Applicable tubing size 1/4" x 5/32"

LQ2E3B-S (Union elbow)

Example

LVQ30S-S11R	1
LQ2T31-S (Union tee)	1
LQ2E3B-S (Union elbow)	1

Note) For shipment, the valve and fittings are individually packaged and dispatched together in 1 box.



Standard Specifications

Model		LVQ20S	LVQ30S	LVQ40S	LVQ50S	LVQ60S
Connection fitting size		2	3	4	5	6
Fitting type	IN/OUT port	LQ1 or LQ2				LQ1
	Pilot port	LQ1				
Orifice diameter		ø4	ø8	ø10	ø16	ø22
Flow characteristics	Av x 10 ⁻⁶ m ²	8.4	31.2	45.6	120	192 (228) ^{Note)}
	Cv	0.35	1.3	1.9	5	8 (9.5) ^{Note)}
Withstand pressure (MPa)		1				
Operating pressure <A→B flow>	Standard	-98 kPa to 0.5 MPa			-98 kPa to 0.4 MPa	
	High temperature	-98 kPa to 0.3 MPa				
Back pressure (MPa)	Standard	0.3 or less			0.2 or less	
	High back pressure	0.42				
	High temperature	0.3 or less			0.2 or less	
Valve leakage (cm ³ /min)		0 (with water pressure)				
Pilot air pressure (MPa)		0.3 to 0.5 (High back pressure: 0.45 to 0.55)				
Pilot port size		1/8" (ø3), ø4, Rc 1/8, NPT 1/8				
Fluid temperature (°C)	Standard	0 to 100				
	High temperature	0 to 170				
Ambient temperature (°C)		0 to 60				
Mass (kg)		0.085	0.175	0.223	0.725	0.835

Note) () is high flow specification.

⚠ Specific Product Precautions

Be sure to read before handling. Refer to front matters 42 and 43 for Safety Instructions, and pages 585 and 586 for High Purity Chemical Valve Non-Metallic Exterior Precautions.

Piping

⚠ Caution

1. Take extra care with the insert bushing when connecting the fittings.
2. Tighten the nut to the end surface of the body. As a guide, refer to the proper tightening torques shown below.

Tightening torque for piping

Body class	Torque (N·m)	
	LQ1	LQ2
2	0.3 to 0.4	1.5 to 2.0
3	0.8 to 1.0	3.0 to 3.5
4	1.0 to 1.2	7.5 to 9.0
5	2.5 to 3.0	11.0 to 13.0
6	5.5 to 6.0	—

Construction

Basic type
N.C. type

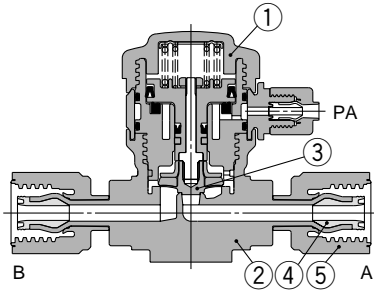

N.O. type

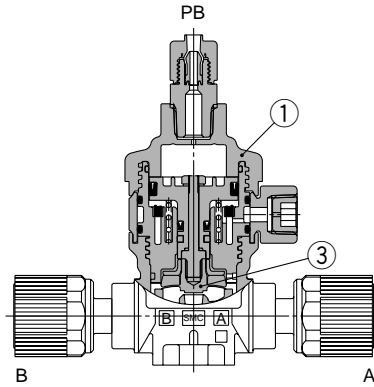

Double acting type

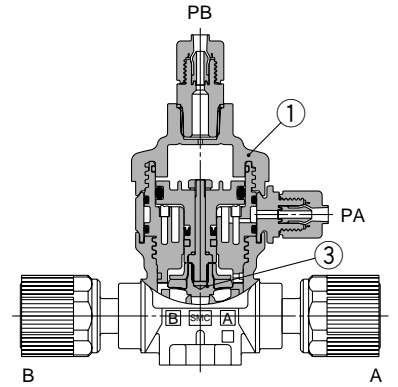

With flow rate adjustment

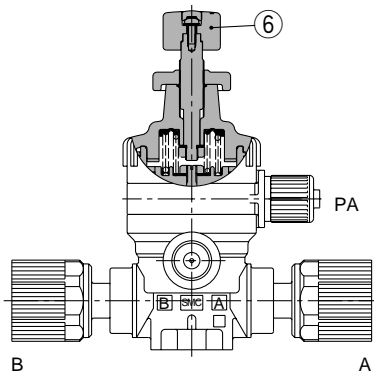

With bypass

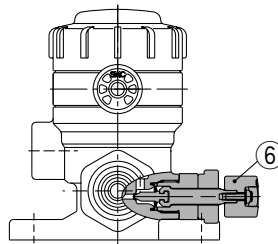

With indicator

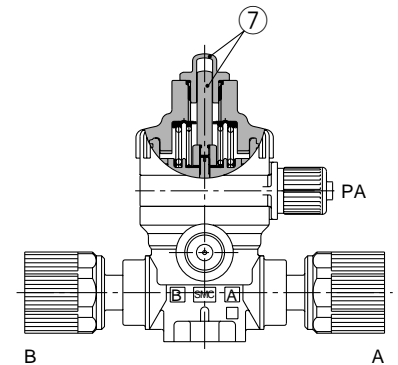

LVC

LVA

LVH

LVD

LVQ

LQ1

LVN

TL/TIL

LQ3

Parts list

No.	Description	Material
1	Actuator section	PVDF
2	Body	PFA
3	Diaphragm	PTFE
4	Insert bushing	PFA
5	Nut	PFA
6	Flow rate adjuster section	PVDF
7	Indicator, cover	PP

Series LVQS

Dimensions

Basic type, High back pressure spec.
N.C. valve

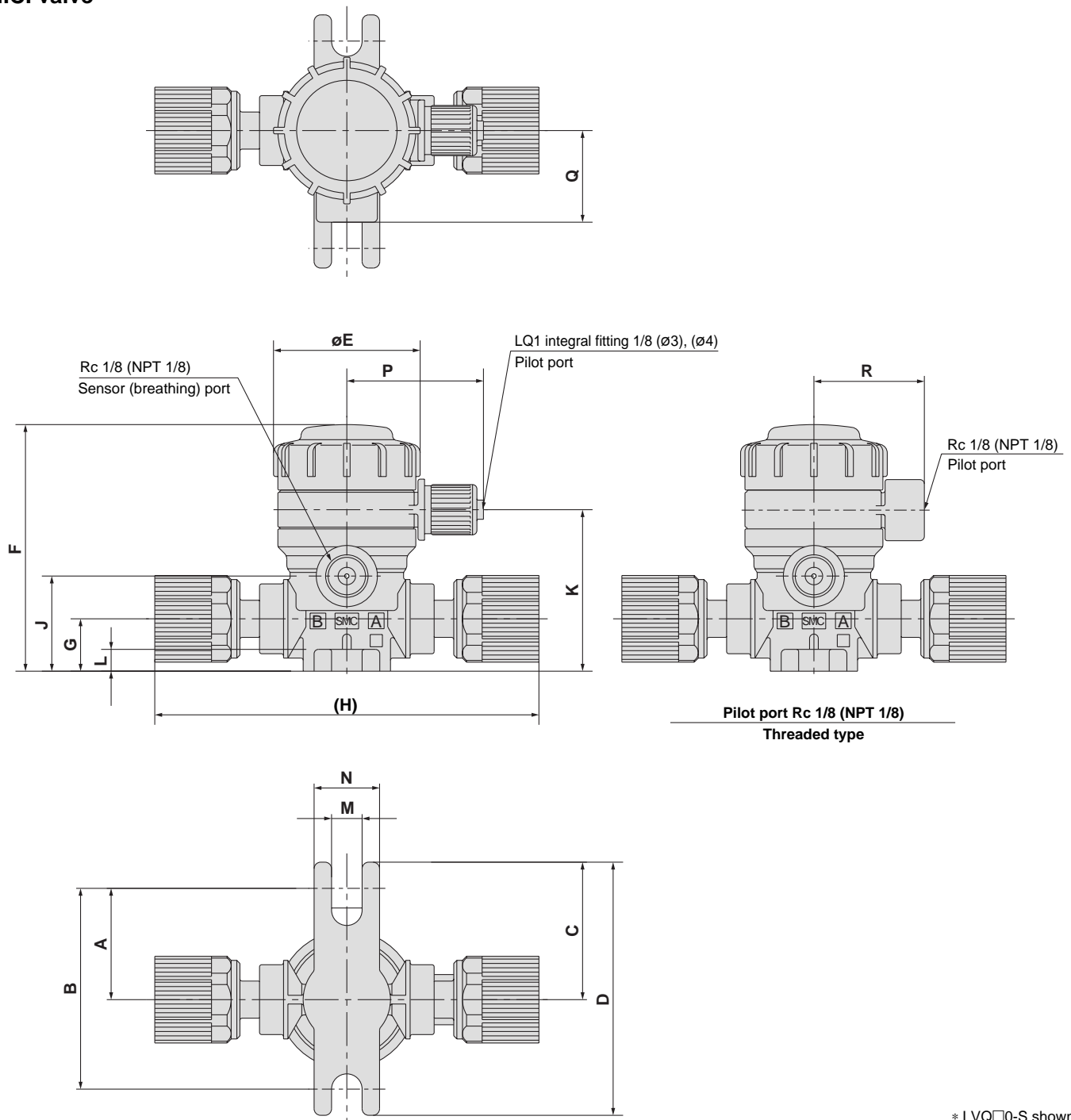

* LVQ□0-S shown.

LVQ□0S-V□□ Dimensions (N.C. valve)

(mm)

Model	A	B	C	D	E	F	G	H		J	K	L	M	N	P	Q	R
								V□	S□								
LVQ20S-V□07	25.5	46	31.5	58	33.6	56.5	12	89	92	21.8	37	5	7	15	31.3	21	25.3
LVQ30S-V□11	28.5	57	34.5	69	45.4	77	16.5	106	112	32	50	6	7	20	37.2	25	31.2
LVQ40S-V□13	28.5	57	34.5	69	45.4	82.5	22	120	126	37.5	55.5	6	7	20	37.2	25	31.2
LVQ50S-V□19	42	84	48	96	75	127	25	164	168	50.2	78.2	10	7	20	50.8	38.5	45
LVQ60S-V25*	42	84	48	96	75	136.8	32	177	—	60	88	10	7	20	50.8	38.5	45

* LVQ60 available only as "V".

With flow rate adjustment, High back pressure spec. with flow rate adjustment

N.C. valve

Dimensions (mm)	
Model	S
LVQ20S- $\frac{V}{S}$ 07-1	83
LVQ30S- $\frac{V}{S}$ 11-1	113.5
LVQ40S- $\frac{V}{S}$ 13-1	119
LVQ50S- $\frac{V}{S}$ 19-1	171.5
LVQ60S-V25-1*	182.5

* LVQ60 available only as "V".

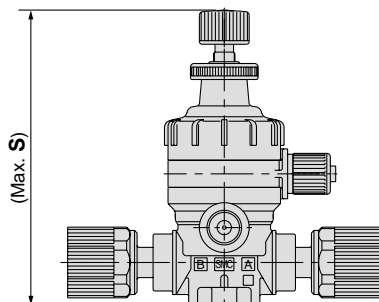

* LVQ□0-S shown.

With bypass, High back pressure spec. with bypass

N.C. valve

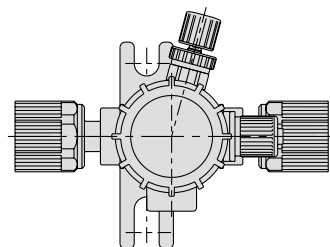

LVQ20S

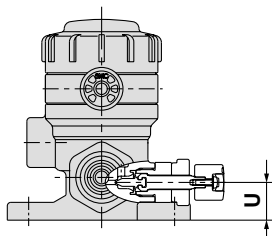
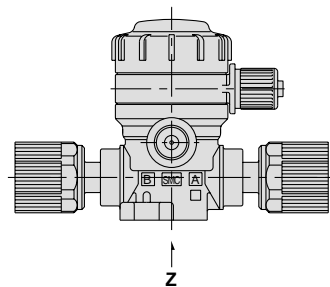
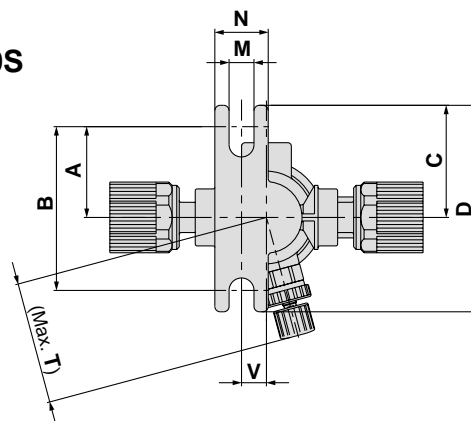

LVQ30S, LVQ40S
LVQ50S, LVQ60S

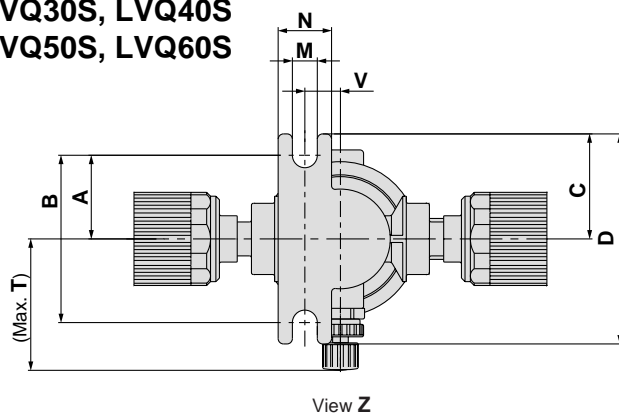

Dimensions (mm)		A	B	C	D	M	N	T	U	V
Model										
LVQ20S- $\frac{V}{S}$ 07-2		25.5	46	31.5	58	7	15	34.3	10.6	7
LVQ30S- $\frac{V}{S}$ 11-2		25.5	51	31.5	63	7	15	36.9	16.5	10
LVQ40S- $\frac{V}{S}$ 13-2		25.5	51	31.5	63	7	15	37.9	22	10
LVQ50S- $\frac{V}{S}$ 19-2		38	76	44	88	7	20	64	25	17
LVQ60S-V25-2*		38	76	44	88	7	20	66	32	17

* LVQ60 available only as "V".

* LVQ□0-S shown.

- LVC
- LVA
- LVH
- LVD
- LVQ**
- LQ1
- LVN
- TL/TIL
- LQ3

Series LVQS

Dimensions

With flow rate adjustment & bypass
High back pressure spec.
with flow rate adjustment & bypass
N.C. valve

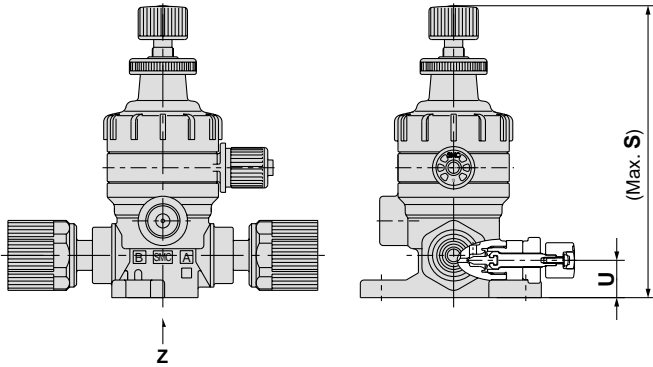
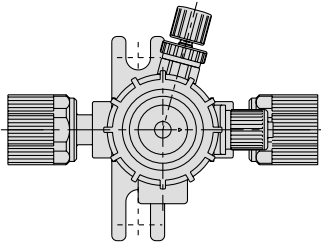

LVQ20S

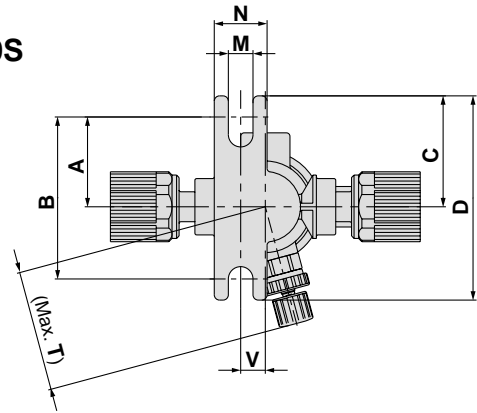

LVQ30S, LVQ40S
LVQ50S, LVQ60S

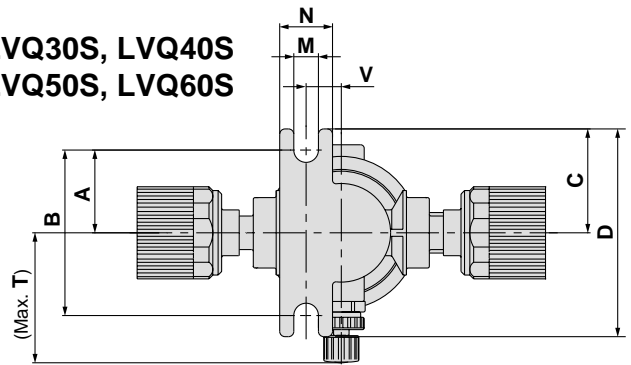

View Z

* LVQ□0-S shown.

Model	A	B	C	D	M	N	S	T	U	V
LVQ20S- ^V / _S 07-3	25.5	46	31.5	58	7	15	83	34.3	10.6	7
LVQ30S- ^V / _S 11-3	25.5	51	31.5	63	7	15	113.5	36.9	16.5	10
LVQ40S- ^V / _S 13-3	25.5	51	31.5	63	7	15	119	37.9	22	10
LVQ50S- ^V / _S 19-3	38	76	44	88	7	20	171.5	64	25	17
LVQ60S-V25-3*	38	76	44	88	7	20	182.5	66	32	17

* LVQ60 available only as "V".

With indicator, High back pressure spec. with indicator
N.C. valve

Model	S
LVQ20S- ^V / _S 07-4	70.5
LVQ30S- ^V / _S 11-4	88.5
LVQ40S- ^V / _S 13-4	94
LVQ50S- ^V / _S 19-4	134.5
LVQ60S-V25-4*	144

* LVQ60 available only as "V".

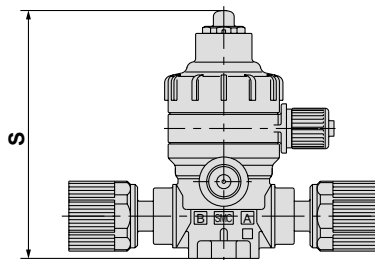

* LVQ□0-S shown.

**Basic type
N.O. valve**

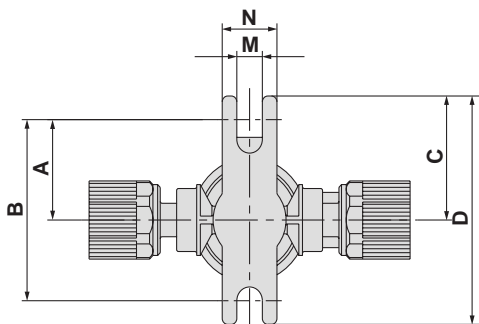
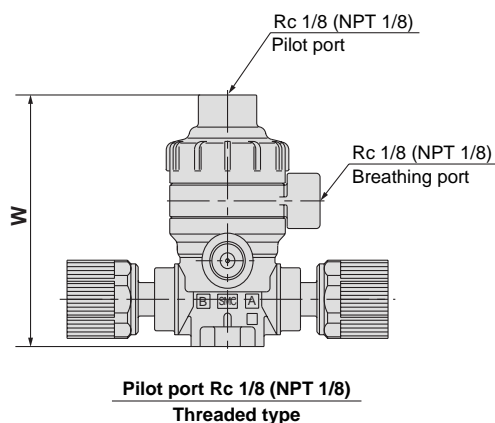
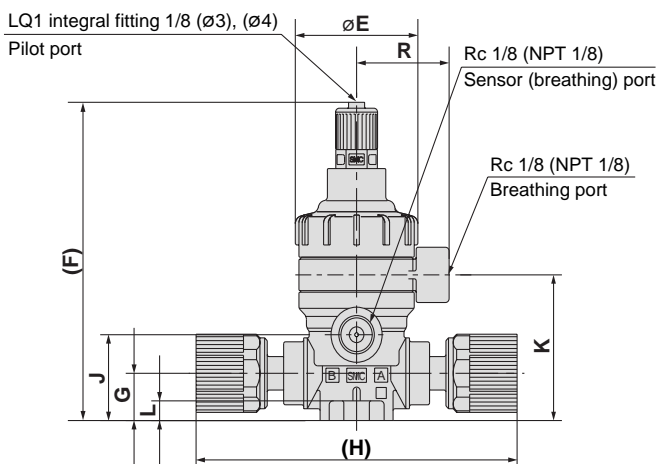
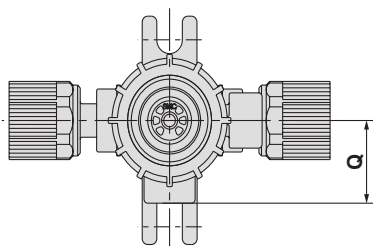

* LVQ□0-S shown.

- LVC
- LVA
- LVH
- LVD
- LVQ**
- LQ1
- LVN
- TL/TIL
- LQ3

Double acting valve

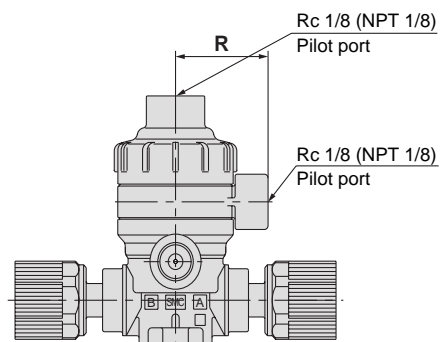
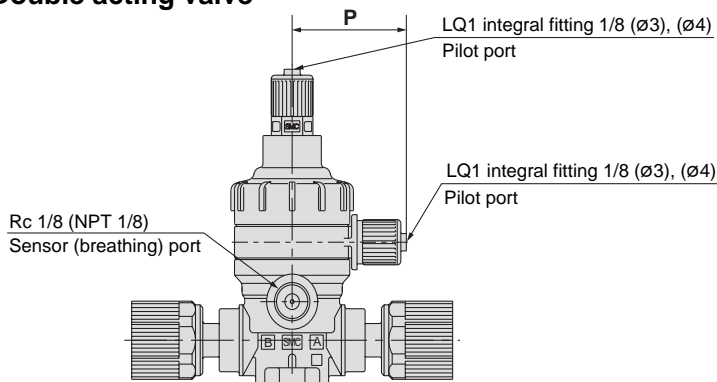

* LVQ□0-S shown.

LVQ□ $\frac{1}{2}$ S-V□□ Dimensions (N.O. valve, double acting valve)

(mm)

Model	A	B	C	D	E	F	G	H		J	K	L	M	N	P	Q	R	W
								V□	S□									
LVQ $\frac{1}{2}$ S-V07	25.5	46	31.5	58	33.6	81	12	89	92	21.8	37	5	7	15	31.3	21	25.3	64
LVQ $\frac{3}{4}$ S-V11	28.5	57	34.5	69	45.4	99	16.5	106	112	32	50	6	7	20	37.2	25	31.2	82
LVQ $\frac{1}{2}$ S-V13	28.5	57	34.5	69	45.4	104.5	22	120	126	37.5	55.5	6	7	20	37.2	25	31.2	87.5
LVQ $\frac{1}{2}$ S-V19	42	84	48	96	75	145	25	164	168	50.2	78.2	10	7	20	50.8	38.5	45	128
LVQ $\frac{1}{2}$ S-V25*	42	84	48	96	75	154.5	32	177	—	60	88	10	7	20	50.8	38.5	45	137.5

* LVQ60 available only as "V".

Series LVQS

Dimensions

With bypass

Double acting valve

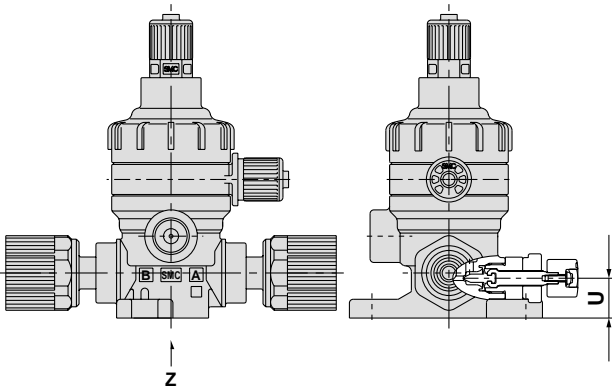
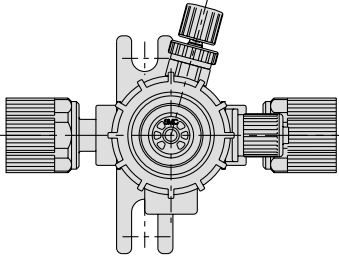

LVQ2 $\frac{1}{2}$ S

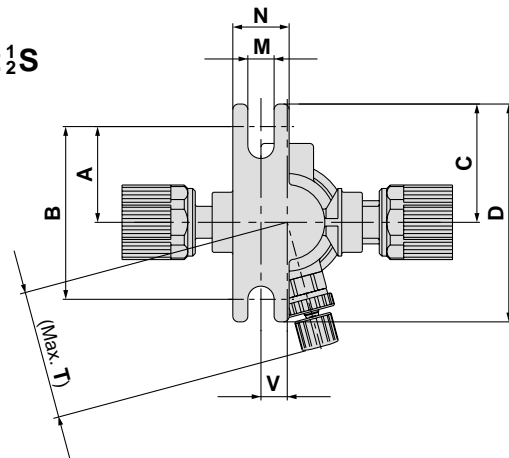

LVQ3 $\frac{1}{2}$ S, LVQ4 $\frac{1}{2}$ S
LVQ5 $\frac{1}{2}$ S, LVQ6 $\frac{1}{2}$ S

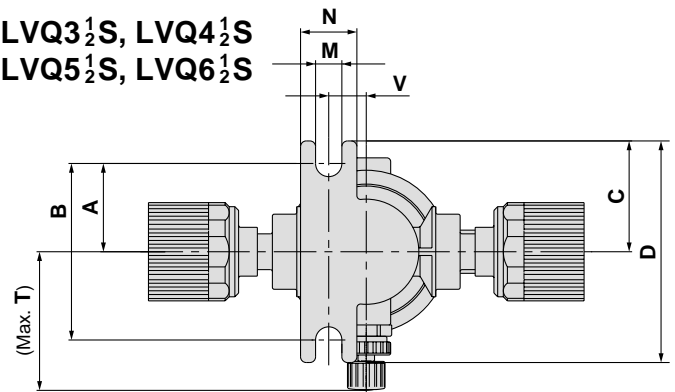

View Z

* LVQ□0-S shown.

Dimensions (N.O. valve, double acting valve)

(mm)

Model	A	B	C	D	M	N	T	U	V
LVQ2 $\frac{1}{2}$ S-V $\frac{1}{8}$ 07-2	25.5	46	31.5	58	7	15	34.3	10.6	7
LVQ3 $\frac{1}{2}$ S-V $\frac{1}{8}$ 11-2	25.5	51	31.5	63	7	15	36.9	16.5	10
LVQ4 $\frac{1}{2}$ S-V $\frac{1}{8}$ 13-2	25.5	51	31.5	63	7	15	37.9	22	10
LVQ5 $\frac{1}{2}$ S-V $\frac{1}{8}$ 19-2	38	76	44	88	7	20	64	25	17
LVQ6 $\frac{1}{2}$ S-V25-2*	38	76	44	88	7	20	66	32	17

* LVQ60 available only as "V".

Manual Type Integral Fitting Type (Hyper Fittings) Series **LVQH**

How to Order

LVQH **2** 0 - **S** **07** - **1** -

Body class

Symbol	Body class	Orifice dia.
2	2	ø4
3	3	ø8
4	4	ø10
5	5	ø16
6	6	ø22

Fitting type

Symbol	Fittings	Body class
V	LQ1	2, 3, 4, 5, 6
S	LQ2	2, 3, 4, 5

Applicable tubing size

Symbol	Connecting tubing O.D.	Body class				
		2	3	4	5	6
Metric sizes						
03	ø3	●				
04	ø4	●				
06	ø6	○	●			
08	ø8		●			
10	ø10		○	●		
12	ø12			○	●	
19	ø19				○	●
25	ø25					○
Inch sizes						
03	1/8	●				
05	3/16	●				
07	1/4	○	●			
11	3/8		○	●		
13	1/2			○	●	
19	3/4				○	●
25	1					○

○ Basic size ● With reducer

Option

Symbol	Note
Nil	Standard
K	Buffer material FFKM
N	For ammonium hydroxide



Note) Options cannot be combined with each other.

Handle operation

1	90 Degree turn type
4	Multi-turn type (with indicator)

Breathing port thread type

Nil	Threaded	NPT 1/8
R	Threaded	Rc 1/8

Port B (OUT) different dia. size

Symbol	Application
Nil	Ports A & B same size
Refer to the applicable tubing table to the left.	Different diameter tubings can be selected within the same body class.

Variations

Type	Symbol	Model				
		LVQH20	LVQH30	LVQH40	LVQH50	LVQH60
		Orifice diameter				
90 Degree turn type		Tubing outside dia.				
		Millimeter				
Multi-turn type		Tubing outside dia.				
		Inch				
		ø4	ø8	ø10	ø16	ø22
		6	10	12	19	25
		1/4	3/8	1/2	3/4	1
		○	○	○	○	○
		○	○	○	○	○

LVC

LVA

LVH

LVD

LVQ

LQ1

LVN

TL/TIL

LQ3



Standard Specifications

Model		LVQH20	LVQH30	LVQH40	LVQH50	LVQH60
Tubing O.D.	Metric size	6	10	12	19	25
	Inch size	1/4	3/8	1/2	3/4	1
Fitting type		LQ1 or LQ2				LQ1
Orifice diameter		ø4	ø8	ø10	ø16	ø22
Flow characteristics	$Av \times 10^{-6}m^2$	8.4	31.2	45.6	120	192 (228) ^{Note)}
	Cv	0.35	1.3	1.9	5	8 (9.5) ^{Note)}
Withstand pressure (MPa)		1				
Operating pressure <A→B flow>		-98 kPa to 0.5 MPa			-98 kPa to 0.4 MPa	
Back pressure (MPa)		0.3 or less			0.2 or less	
Valve leakage (cm ³ /min)		0 (With water pressure)				
Fluid temperature (°C)		0 to 100				
Ambient temperature (°C)		0 to 60				
Mass (kg)	LVQH□0-1	0.12	0.27	0.31	1.10	1.16
	LVQH□0-4	0.11	0.20	0.22	0.67	0.87

Note) () is high flow specification.

⚠ Specific Product Precautions

Be sure to read before handling. Refer to front matters 42 and 43 for Safety Instructions, and pages 585 and 586 for High Purity Chemical Valve Non-Metallic Exterior Precautions.

Piping

⚠ Caution

1. Connect tubing with special tools.

Refer to the pamphlet "High-Purity Fluoropolymer Fittings HYPER FITTING®/Series LQ1, 2 Work Procedure Instructions" (M-E05-1) for connecting tubing and special tools. (Downloadable from our web site.)

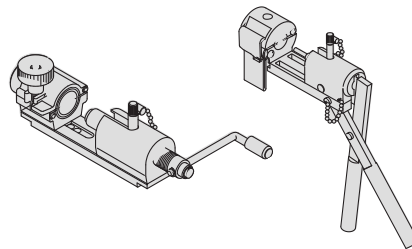

2. Tighten the nut to the end surface of the body. As a guide, refer to the proper tightening torques shown below.

Tightening torque for piping

Body class	Torque (N·m)	
	LQ1	LQ2
2	0.3 to 0.4	1.5 to 2.0
3	0.8 to 1.0	3.0 to 3.5
4	1.0 to 1.2	7.5 to 9.0
5	2.5 to 3.0	11.0 to 13.0
6	5.5 to 6.0	—

Construction

90 Degree turn type

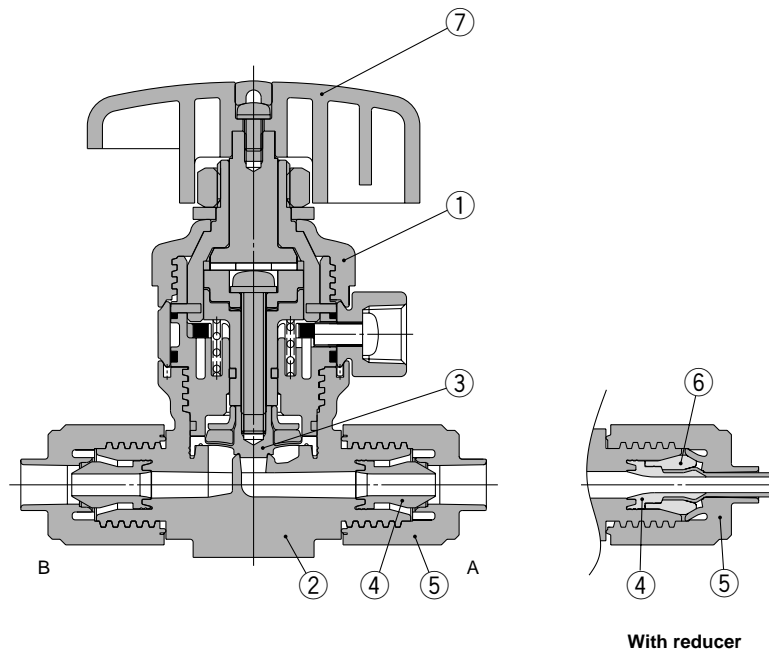

LVC
LVA
LVH
LVD
LVQ
LQ1
LVN
TL/TIL
LQ3

Multi-turn type (with indicator)

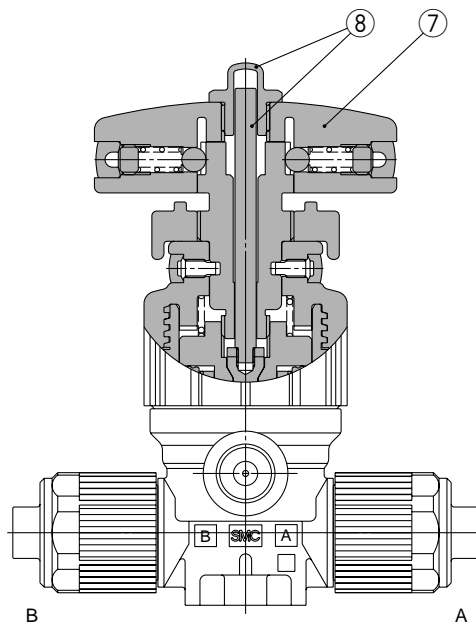

Parts list

No.	Description	Material
1	Actuator section	PVDF
2	Body	PFA
3	Diaphragm	PTFE
4	Insert bushing	PFA
5	Nut	PFA
6	Collar	PFA
7	Handle section	PVDF
8	Indicator, cover	PP

Series LVQH

Dimensions

90 Degree turn type

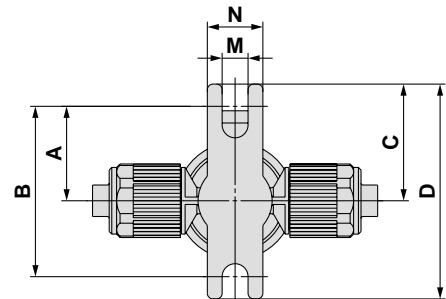
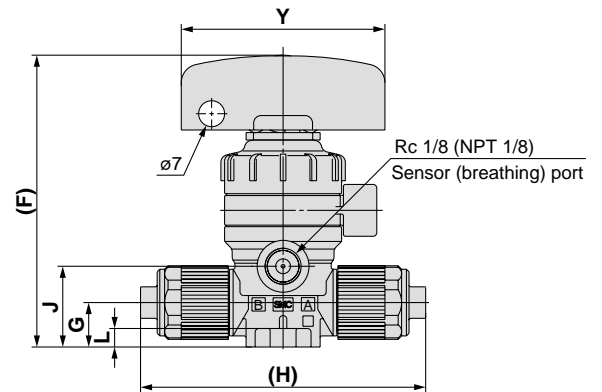
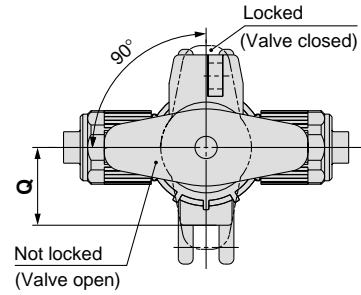

Dimensions (mm)

Model	A	B	C	D	F	G	H	
							V□	S□
LVQH20-V□-1	25.5	46	31.5	58	79	12	70	77
LVQH30-V□-1	28.5	57	34.5	69	103	16.5	83	95
LVQH40-V□-1	28.5	57	34.5	69	108	22	95	109
LVQH50-V□-1	42	84	48	96	165	25	130	141
LVQH60-V□-1*	42	84	48	96	175	32	150	—

Model	J	K	L	M	N	Q	Y
LVQH20-V□-1	21.8	37	5	7	15	21	55
LVQH30-V□-1	32	50	6	7	20	25	80
LVQH40-V□-1	37.5	55.5	6	7	20	25	80
LVQH50-V□-1	50.2	78.2	10	7	20	38.5	110
LVQH60-V□-1*	60	88	10	7	20	38.5	110

* LVQ60 available only as "V".
* LVQ□0-S shown.

Multi-turn type (with indicator)

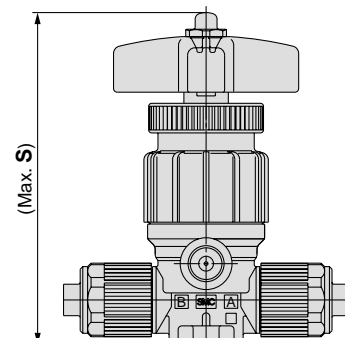
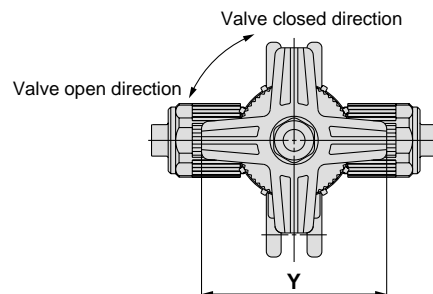

Dimensions (mm)

Model	S	Y
LVQH20-V□-4	89.6	50
LVQH30-V□-4	107.2	50
LVQH40-V□-4	112.7	50
LVQH50-V□-4	165	71
LVQH60-V□-4*	174.5	71

* LVQ60 available only as "V".
* LVQ□0-S shown.

Manual Type Integral Fitting Type Space Saving/Space Saving Connection Series **LVQHS**

How to Order

LVQH **2** **0** **S** - **S** **07** **1** - **1** - **1**

Body class

Symbol	Body class	Orifice dia.
2	2	ø4
3	3	ø8
4	4	ø10
5	5	ø16
6	6	ø22

Body type

S	Space saving connection
----------	-------------------------

Fitting type

Symbol	Fittings	Body class
V	LQ1	2, 3, 4, 5, 6
S	LQ2	2, 3, 4, 5

Option

Symbol	Note
Nil	Standard
K	Buffer material FFKM
N	For ammonium hydroxide

Note) Options cannot be combined with each other.

Handle operation

1	90 Degree turn type
4	Multi-turn type (with indicator)

Breathing port thread type

Nil	Threaded	NPT 1/8
R	Threaded	Rc 1/8

Applicable fitting size

Symbol	Connecting tubing O.D.	Body class				
		2	3	4	5	6
07	1/4	○				
11	3/8		○			
13	1/2			○		
19	3/4				○	
25	1					○

Note) Refer to page 540 for How to order fitting parts.
Select the fittings of the same size as the one at the valve side.

LVC

LVA

LVH

LVD

LVQ

LQ1

LVN

TL/TIL

LQ3

Variations

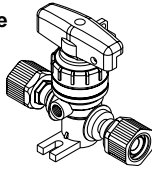
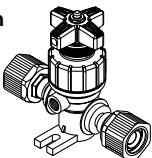
Type	Model	Orifice diameter				
		LVQH20S	LVQH30S	LVQH40S	LVQH50S	LVQH60S
		ø4	ø8	ø10	ø16	ø22
		2	3	4	5	6
90 Degree turn type		○	○	○	○	○
Multi-turn type		○	○	○	○	○

How to Order Fittings for Space Saving

Applicable tubing size

Size	No.	Applicable tubing size (mm)	Reducing
2	1	6 x 4	○
2	2	4 x 3	●
3	1	10 x 8	○
3	2	8 x 6	●
3	3	6 x 4	●
4	1	12 x 10	○
4	2	10 x 8	●
5	1	19 x 16	○
5	2	12 x 10	●
6	1	25 x 22	○
6	2	19 x 16	●

Size	Symbol	Applicable tubing size (inch)	Reducing
2	A	1/4" x 5/32"	○
2	B	3/16" x 1/8"	●
2	C	1/8" x 0.086"	●
3	A	3/8" x 1/4"	○
3	B	1/4" x 5/32"	●
4	A	1/2" x 3/8"	○
4	B	3/8" x 1/4"	●
5	A	3/4" x 5/8"	○
5	B	1/2" x 3/8"	●
6	A	1" x 7/8"	○
6	B	3/4" x 5/8"	●

○ Basic size ● With reducer



Note 1) Select a fitting the same size as the valve fitting.

LQ1 E 61 - S
LQ2 E 21 - S

One nut (including insert bushing) of the nuts is not attached.

Type of fitting

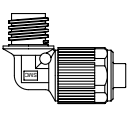
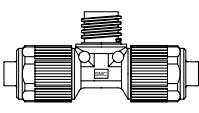
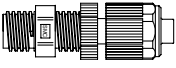
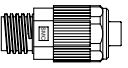
E	T
Union elbow 	Union tee 
P	U
Panel mount union 	Union 

Applicable tubing size

Size	No.	Applicable tubing size (mm)	Reducing
2	1	6 x 4	○
2	2	4 x 3	●
3	1	10 x 8	○
3	2	8 x 6	●
3	3	6 x 4	●
4	1	12 x 10	○
4	2	10 x 8	●
5	1	19 x 16	○
5	2	12 x 10	●

Size	Symbol	Applicable tubing size (inch)	Reducing
2	A	1/4" x 5/32"	○
2	B	3/16" x 1/8"	●
2	C	1/8" x 0.086"	●
3	A	3/8" x 1/4"	○
3	B	1/4" x 5/32"	●
4	A	1/2" x 3/8"	○
4	B	3/8" x 1/4"	●
5	A	3/4" x 5/8"	○
5	B	1/2" x 3/8"	●

○ Basic size ● With reducer



Note 1) Select a fitting the same size as the valve fitting.

Piping example

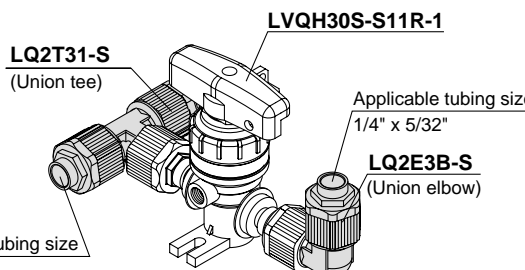

LVQH30S-S11R-1

LQ2T31-S (Union tee)

LQ2E3B-S (Union elbow)

Applicable tubing size 10 x 8

Applicable tubing size 1/4" x 5/32"

Example

LVQH30S-S11R-1	1
LQ2T31-S (Union tee)	1
LQ2E3B-S (Union elbow)	1

Note) For shipment, the valve and fittings are individually packaged and dispatched together in 1 box.

Standard Specifications



Model		LVQH20S	LVQH30S	LVQH40S	LVQH50S	LVQH60S
Connection fitting size		2	3	4	5	6
Fitting type		LQ1 or LQ2				LQ1
Orifice diameter		ø4	ø8	ø10	ø16	ø22
Flow characteristics	Av x 10 ⁻⁶ m ²	8.4	31.2	45.6	120	192 (228) ^{Note)}
	Cv	0.35	1.3	1.9	5	8 (9.5) ^{Note)}
Withstand pressure (MPa)		1				
Operating pressure <A→B flow>		-98 kPa to 0.5 MPa			-98 kPa to 0.4 MPa	
Back pressure (MPa)		0.3 or less			0.2 or less	
Valve leakage (cm ³ /min)		0 (With water pressure)				
Fluid temperature (°C)		0 to 100				
Ambient temperature (°C)		0 to 60				
Mass (kg)	LVQH□0S-1	0.14	0.30	0.33	1.14	1.18
	LVQH□S0-4	0.13	0.23	0.24	0.71	0.89

Note) () is high flow specification.

⚠ Specific Product Precautions

Be sure to read before handling. Refer to front matters 42 and 43 for Safety Instructions, and pages 585 and 586 for High Purity Chemical Valve Non-Metallic Exterior Precautions.

Piping

⚠ Caution

1. Take extra care with the insert bushing when connecting the fittings.
2. Tighten the nut to the end surface of the body. As a guide, refer to the proper tightening torques shown below.

Tightening torque for piping

Body class	Torque (N·m)	
	LQ1	LQ2
2	0.3 to 0.4	1.5 to 2.0
3	0.8 to 1.0	3.0 to 3.5
4	1.0 to 1.2	7.5 to 9.0
5	2.5 to 3.0	11.0 to 13.0
6	5.5 to 6.0	—

LVC

LVA

LVH

LVD

LVQ

LQ1

LVN

TL/TIL

LQ3

Series LVQHS

Construction

90 Degree turn type

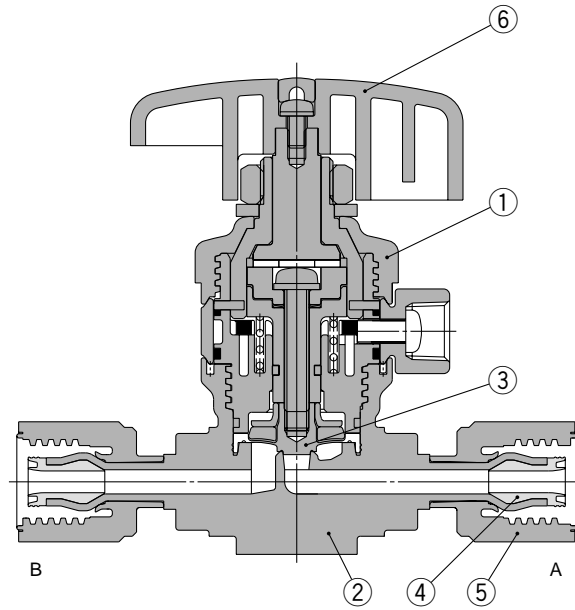

Multi-turn type (with indicator)

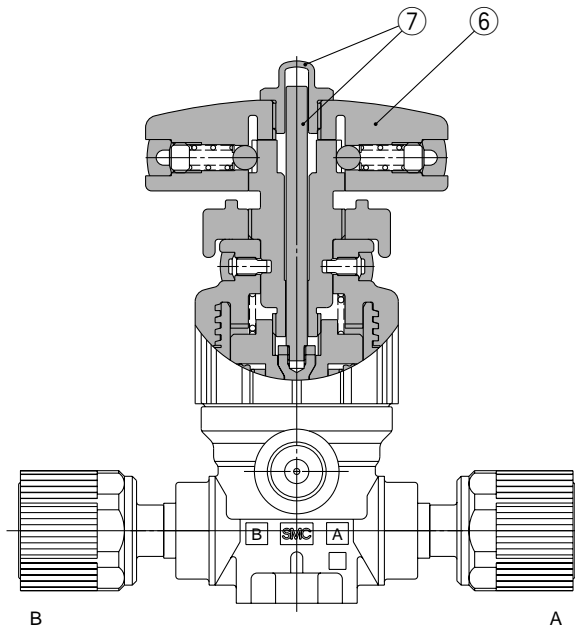

Parts list

No.	Description	Material
1	Actuator section	PVDF
2	Body	PFA
3	Diaphragm	PTFE
4	Insert bushing	PFA
5	Nut	PFA
6	Handle section	PVDF
7	Indicator, cover	PP

Dimensions

90 Degree turn type

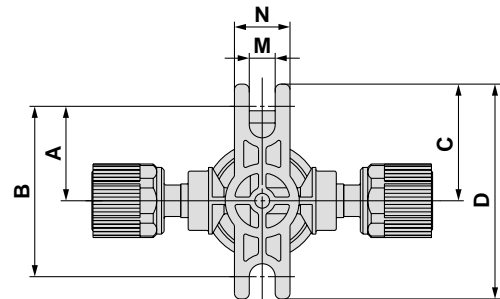
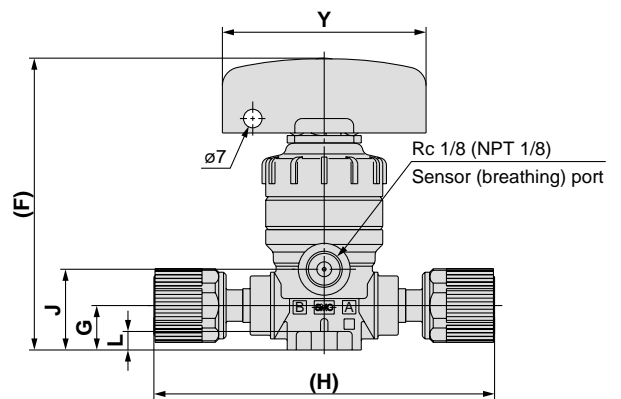
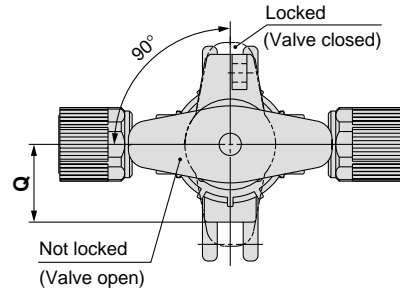

Dimensions (mm)

Model	A	B	C	D	F	G	H	
							V□	S□
LVQH20S-V□-1	25.5	46	31.5	58	79	12	89	92
LVQH30S-V□-1	28.5	57	34.5	69	103	16.5	106	112
LVQH40S-V□-1	28.5	57	34.5	69	108	22	120	126
LVQH50S-V□-1	42	84	48	96	165	25	164	168
LVQH60S-V□-1*	42	84	48	96	175	32	177	—

Model	J	L	M	N	Q	Y
LVQH20S-V□-1	21.8	5	7	15	21	55
LVQH30S-V□-1	32	6	7	20	25	80
LVQH40S-V□-1	37.5	6	7	20	25	80
LVQH50S-V□-1	50.2	10	7	20	38.5	110
LVQH60S-V□-1*	60	10	7	20	38.5	110

* LVQ60 available only as "V".
* LVQ□0-S shown.

Multi-turn type (with indicator)

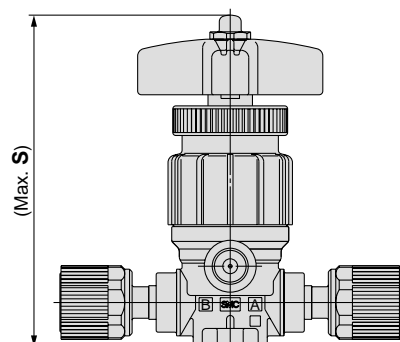
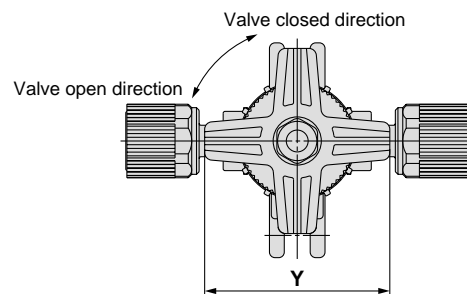

Dimensions (mm)

Model	S	Y
LVQH20S-V□-4	89.6	50
LVQH30S-V□-4	107.2	50
LVQH40S-V□-4	112.7	50
LVQH50S-V□-4	165	71
LVQH60S-V□-4*	174.5	71

* LVQ60 available only as "V".
* LVQ□0-S shown.

- LVC
- LVA
- LVH
- LVD
- LVQ**
- LQ1
- LVN
- TL/TIL
- LQ3

Series LVQ Fittings and Special Tools

Fittings

Changing tubing sizes

The tubing size can be changed within the same body class (body size) by replacing the nut and insert bushing.

Body class	Tubing O.D.													
	Metric sizes							Inch sizes						
	4	6	8	10	12	19	25	1/8	3/16	1/4	3/8	1/2	3/4	1
2	●	○	—	—	—	—	—	●	●	○	—	—	—	—
3	—	●	●	○	—	—	—	—	—	●	○	—	—	—
4	—	—	—	●	○	—	—	—	—	—	●	○	—	—
5	—	—	—	—	●	○	—	—	—	—	—	●	○	—
6	—	—	—	—	—	●	○	—	—	—	—	—	●	○

Part composition

	Component parts		
	Nut	Insert	Collar (insert assembly)
○ Basic size	Yes	Yes	No
● Reducer type	Yes	Yes	Yes

⚠ Caution

1. Connect tubing with special tools.

Refer to the pamphlet "High-Purity Fluoro polymer Fittings HYPER FITTING®/Series LQ1, 2 Work Procedure Instructions" (M-E05-1) for connecting tubing and special tools. (Downloadable from our web site.)

Changing the tubing size

Example) Changing the tubing from an O.D. 1/4" to O.D. 1/8" in body class 2.

Prepare an insert bushing and nut for 1/8" O.D. tubing (LQ-2U03) and change the tubing size.

(Refer to the section on how to order fitting parts.)

Note) Tubing is sold separately.

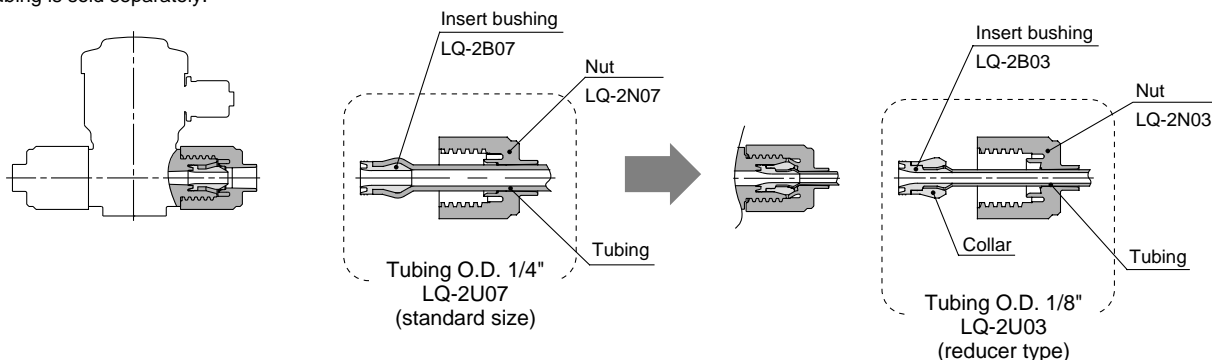

How to order fitting parts

LQ 2 U 03 * Type U is recommended when changing tubing sizes.

Type of fitting

Symbol	Applicable fitting
Nil	LQ2
1	LQ1

Body class

Symbol	Body class	Applicable fitting
2	2	LQ1
3	3	
4	4	LQ2
5	5	LQ1
6	6	

Type of part

Symbol	Type of part
U	Nut & insert bushing
B	Insert bushing
N	Nut

Tubing size

Symbol	Tubing O.D.	Body class	Applicable fitting
03	1/8" (ø3)	2	LQ1
04	ø4		
05	3/16"		
06	ø6		
07	1/4"		
08	ø8		
06	ø6	3	LQ2
10	ø10		
07	1/4"		
11	3/8"		
12	ø12		
11	3/8"		
13	1/2"		
12	ø12	5	LQ2
13	1/2"		
19	3/4", ø19	6	LQ1
19	3/4", ø19		
25	1", ø25		

For pilot port

LQ1 1 U 03

Body class

Symbol	Body class	Applicable fitting
1	1	LQ1

Type of part

Symbol	Type of part
U	Nut & insert bushing
B	Insert bushing
N	Nut

Tubing size

Symbol	Tubing O.D.	Body class
03	1/8" (ø3)	1
04	ø4	

Note) Cannot change to tubing of different diameter.

Air Operated Type Flare Integral Fitting Type (Hyper Fittings) Series **LVQ-Z**

How to Order

LVQ **2** **0** - **Z** **07** □ - □ - □

Body class

Symbol	Body class	Orifice dia.
2	2	ø4
3	3	ø8
4	4	ø10
5	5	ø16
6	6	ø22

Valve type

0	N.C.
1	N.O.
2	Double acting

Note) Refer to variations in the table below for valve type combinations.

LQ3 integral fittings

Applicable fitting size

Symbol	Connecting tubing O.D.	Body class					
		2	3	4	5	6	
Metric sizes							
03	ø3	○					
04	ø4	○					
06	ø6	○					
08	ø8		○				
10	ø10		○				
12	ø12			○			
19	ø19				○		
25	ø25					○	
Inch sizes							
07	1/4	○					
11	3/8		○				
13	1/2			○			
19	3/4				○		
25	1					○	

Pilot port thread type

Nil	LQ3 integral fitting	Connection tubing O.D. 1/8" (ø3)
M	LQ3 integral fitting	Connection tubing O.D. ø4
R	Threaded	Rc 1/8
N	Threaded	NPT 1/8

Option (1)

Nil	None	6	High back pressure with flow rate adjustment
1	With flow rate adjustment	7	High back pressure with bypass
2	With bypass	8	High back pressure with flow rate adjustment & bypass
3	With flow rate adjustment & bypass	9	High back pressure with indicator
4	With indicator	24	With indicator & bypass
5	High back pressure (0.42 MPa)		

Note) Refer to variations in the table below for valve type and option (1) combinations. Options (1) can not be combined each other.

Option (2)

Symbol	Applicable option										Note
	1	2	3	4	5	6	7	8	9	24	
Nil	○	○	○	○	○	○	○	○	○	○	—
J	○	—	—	—	○	○	—	—	—	—	For high temperature
K	○	○	○	○	○	○	○	○	○	○	Buffer material FFKM
N	○	○	○	○	○	○	○	○	○	○	For ammonium hydroxide
P	—	—	—	○	○	—	—	—	—	—	High flow spec. LVQ6□ only

Note) Options (2) cannot be combined with each other.

Variations

Type	Symbol	Valve type	Model					
			LVQ20	LVQ30	LVQ40	LVQ50	LVQ60	
			Orifice diameter		Tubing outside dia.			
		Millimeter	6	10	12	19	25	
		Inch	1/4	3/8	1/2	3/4	1	
Basic type								
N.C.		N.C.	○	○	○	○	○	
N.O.		N.O.	○	○	○	○	○	
Double acting		Double acting	○	○	○	○	○	
With flow rate adjustment								
N.C.		N.C.	○	○	○	○	○	
With bypass								
N.C.		N.C.	○	○	○	○	○	
Double acting		Double acting	○	○	○	○	○	
With flow rate adjustment & bypass								
N.C.		N.C.	○	○	○	○	○	
With indicator								
N.C.		N.C.	○	○	○	○	○	
High back pressure								
N.C.		N.C.	○	○	○	○	○	
With indicator & bypass								
N.C.		N.C.	○	○	○	○	○	



Standard Specifications

Model		LVQ20	LVQ30	LVQ40	LVQ50	LVQ60
Tubing O.D.	Metric size	6	10	12	19	25
	Inch size	1/4	3/8	1/2	3/4	1
Orifice diameter		ø4	ø8	ø10	ø16	ø22
Flow characteristics	$Av \times 10^{-6} m^2$	8.4	31.2	45.6	120	192 (228) ^{Note)}
	Cv	0.35	1.3	1.9	5	8 (9.5) ^{Note)}
Withstand pressure (MPa)		1				
Operating pressure <A→B flow>	Standard	-98 kPa to 0.5 MPa			-98 kPa to 0.4 MPa	
	High temperature	-98 kPa to 0.3 MPa				
Back pressure (MPa)	Standard	0.3 or less			0.2 or less	
	High back pressure	0.42				
	High temperature	0.3 or less			0.2 or less	
Valve leakage (cm ³ /min)		0 (With water pressure)				
Pilot air pressure (MPa)		0.3 to 0.5 (High back pressure: 0.45 to 0.55)				
Pilot port size		1/8" (ø3), ø4, Rc 1/8, NPT 1/8				
Fluid temperature (°C)	Standard	0 to 100				
	High temperature	0 to 170				
Ambient temperature (°C)		0 to 60				
Mass (kg)		0.08	0.18	0.22	0.72	0.87

Note) () is high flow specification.

⚠ Specific Product Precautions

Be sure to read before handling. Refer to front matters 42 and 43 for Safety Instructions, and pages 585 and 586 for High Purity Chemical Valve Non-Metallic Exterior Precautions.

Piping

⚠ Caution

1. Connect tubing with special tools.

Refer to the pamphlet "High-Purity Fluoropolymer Fittings HYPER FITTING®/Flare Type Series LQ3 Fitting Procedure" (M-E06-4) for connecting tubing and special tools. (Downloadable from our web site.)

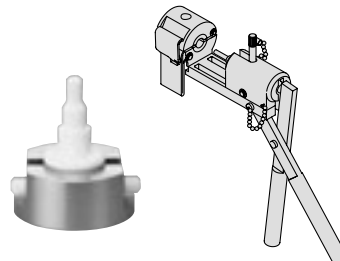

2. Tighten the nut to the end surface of the body. As a guide, refer to the proper tightening torques shown below.

Tightening torque for piping

Body class	Torque (N·m)
2	1.6 to 1.8
3	3.2 to 3.5
4	5.0 to 5.3
5	10.0 to 10.5
6	22.5 to 23.0

Construction

Basic type

N.C. type

N.O. type

Double acting type

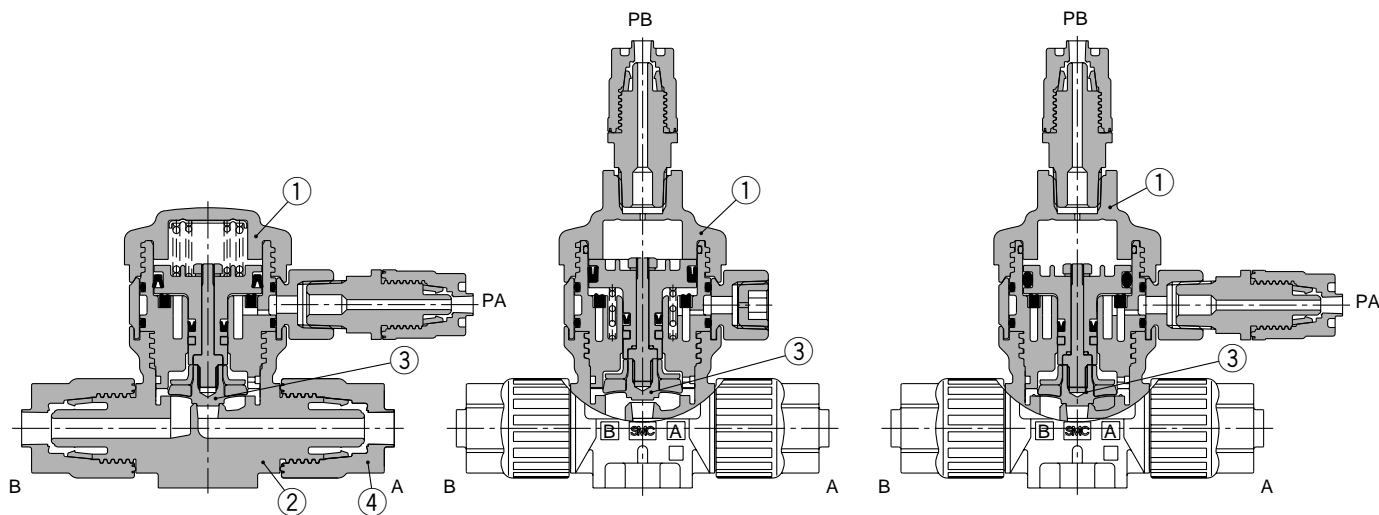

LVC

LVA

LVH

LVD

LVQ

LQ1

LVN

TL/TIL

LQ3

With flow rate adjustment

With bypass

With indicator

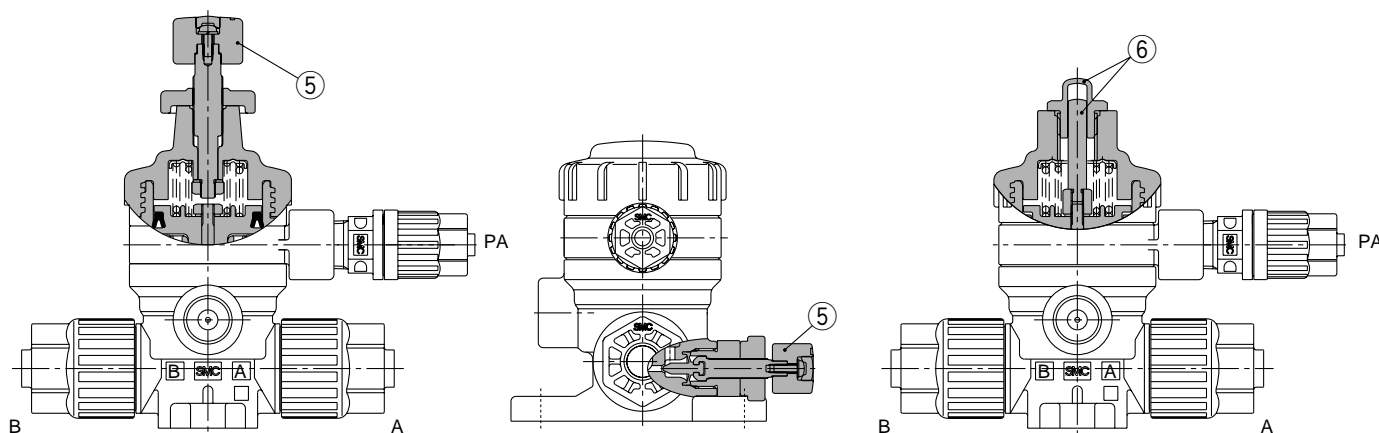

Parts list

No.	Description	Material
1	Actuator section	PVDF
2	Body	PFA
3	Diaphragm	PTFE
4	Nut	PFA
5	Flow rate adjuster section	PVDF
6	Indicator, cover	PP

Series LVQ-Z

Dimensions

Basic type, High back pressure spec.

N.C. valve

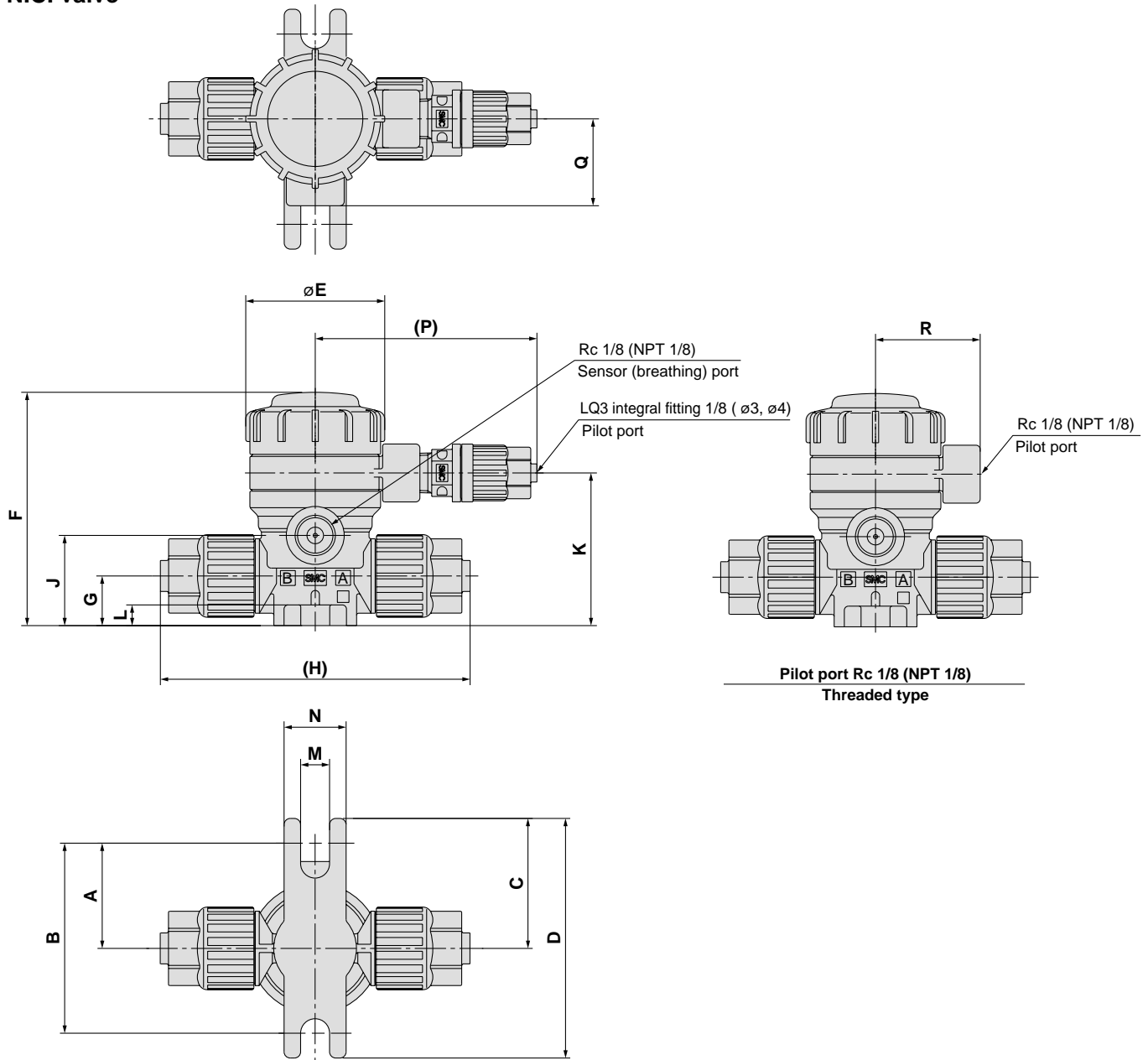

LVQ□0-Z□□ Dimensions (N.C. valve)

(mm)

Model	A	B	C	D	E	F	G	H	J	K	L	M	N	P	Q	R
LVQ20-Z□□	25.5	46	31.5	58	33.6	56.5	12	75	21.8	37	5	7	15	53.5	21	25.3
LVQ30-Z□□	28.5	57	34.5	69	45.4	77	16.5	103	32	50	6	7	20	59.5	25	31.2
LVQ40-Z□□	28.5	57	34.5	69	45.4	82.5	22	114	37.5	55.5	6	7	20	59.5	25	31.2
LVQ50-Z□□	42	84	48	96	75	127	25	150	50.2	78.2	10	7	20	73	38.5	45
LVQ60-Z□□	42	84	48	96	75	136.8	32	167	60	88	10	7	20	73	38.5	45

**With flow rate adjustment
N.C. valve**

Dimensions (mm)	
Model	S
LVQ20-Z□□-1	83
LVQ30-Z□□-1	113.5
LVQ40-Z□□-1	119
LVQ50-Z□□-1	171.5
LVQ60-Z□□-1	182.5

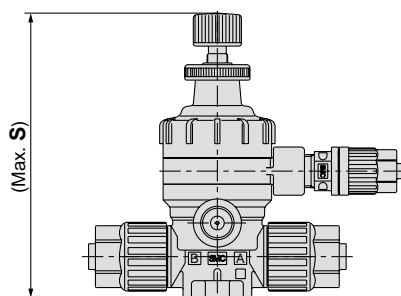

**With bypass
N.C. valve**

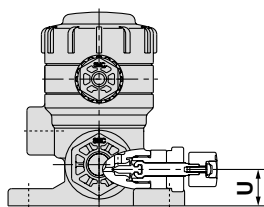
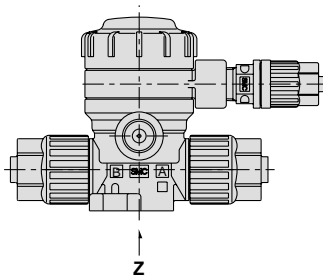
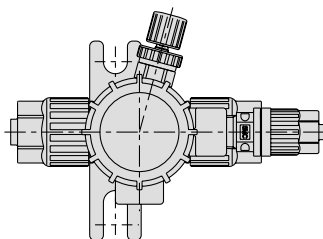

LVQ20

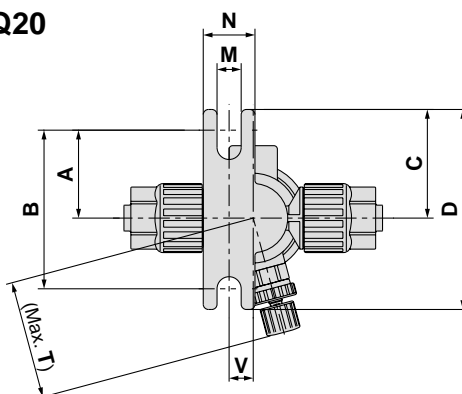

**LVQ30, LVQ40
LVQ50, LVQ60**

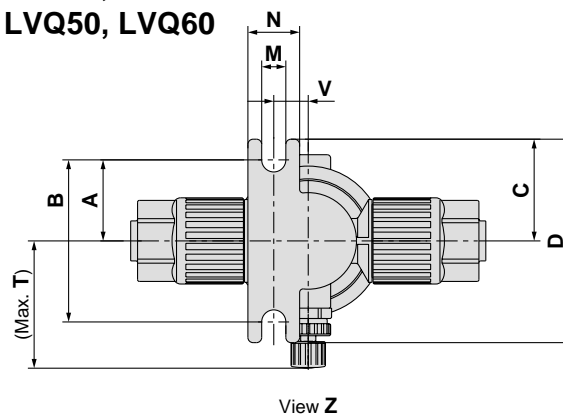

Dimensions (mm)									
Model	A	B	C	D	M	N	T	U	V
LVQ20-Z□□-2	25.5	46	31.5	58	7	15	34.3	10.6	7
LVQ30-Z□□-2	25.5	51	31.5	63	7	15	36.9	16.5	10
LVQ40-Z□□-2	25.5	51	31.5	63	7	15	37.9	22	10
LVQ50-Z□□-2	38	76	44	88	7	20	64	25	17
LVQ60-Z□□-2	38	76	44	88	7	20	66	32	17

- LVC
- LVA
- LVH
- LVD
- LVQ**
- LQ1
- LVN
- TL/TIL
- LQ3

Series LVQ-Z

Dimensions

With flow rate adjustment & bypass
N.C. valve

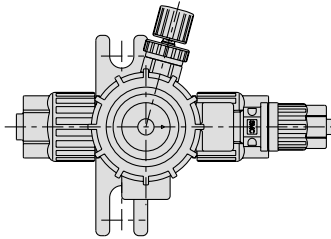

LVQ20

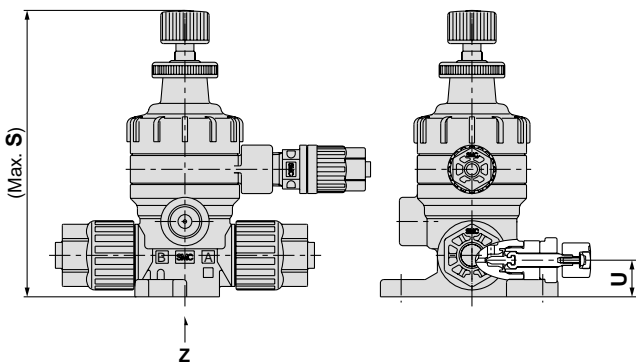
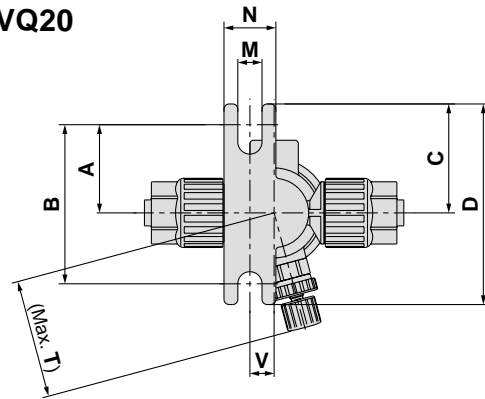

LVQ30, LVQ40
LVQ50, LVQ60

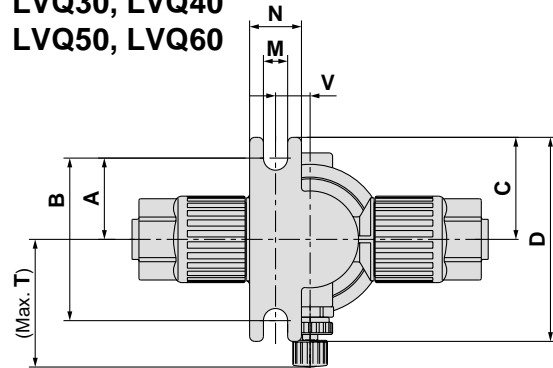

View Z

Dimensions (mm)

Model	A	B	C	D	M	N	S	T	U	V
LVQ20-Z□□-3	25.5	46	31.5	58	7	15	83	34.3	10.6	7
LVQ30-Z□□-3	25.5	51	31.5	63	7	15	113.5	36.9	16.5	10
LVQ40-Z□□-3	25.5	51	31.5	63	7	15	119	37.9	22	10
LVQ50-Z□□-3	38	76	44	88	7	20	171.5	64	25	17
LVQ60-Z□□-3	38	76	44	88	7	20	182.5	66	32	17

With indicator
N.C. valve

Dimensions (mm)

Model	S
LVQ20-Z□□-4	70.5
LVQ30-Z□□-4	88.5
LVQ40-Z□□-4	94
LVQ50-Z□□-4	134.5
LVQ60-Z□□-4	144

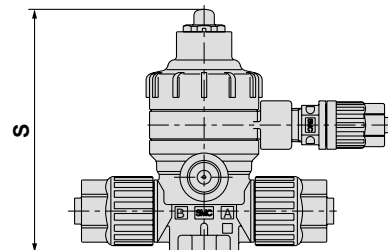

**Basic type
N.O. valve**

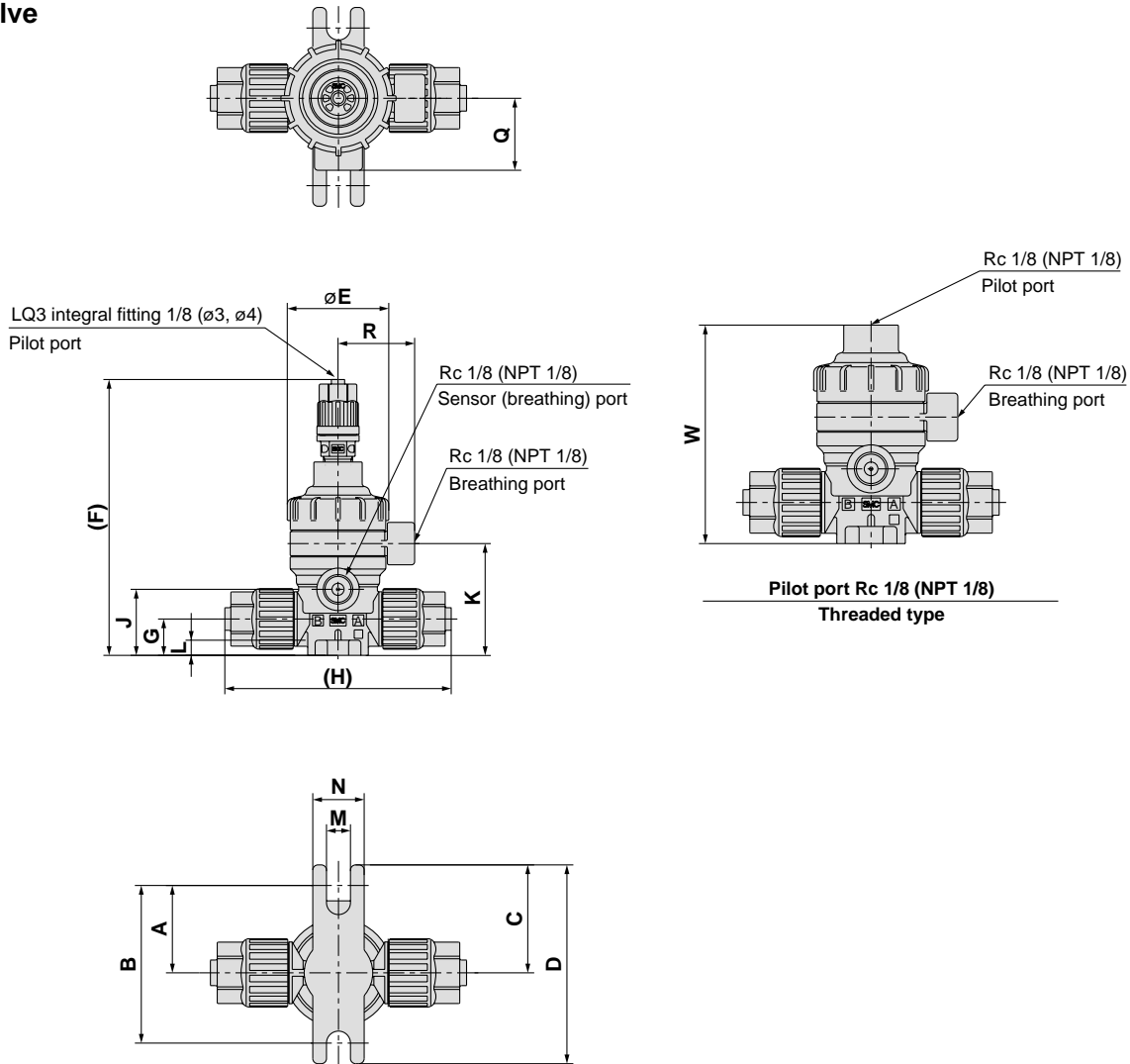

- LVC
- LVA
- LVH
- LVD
- LVQ**
- LQ1
- LVN
- TL/TIL
- LQ3

Double acting valve

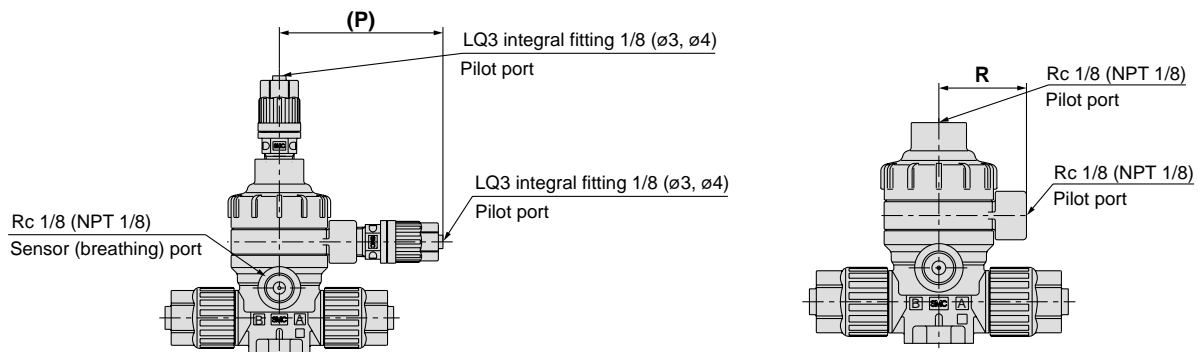

LVQ□₂-Z□□ Dimensions (N.O. valve, double acting valve)

Model	A	B	C	D	E	F	G	H	J	K	L	M	N	P	Q	R	W
LVQ2 ₂ -Z□□	25.5	46	31.5	58	33.6	89.5	12	75	21.8	37	5	7	15	53.5	21	25.3	64
LVQ3 ₂ -Z□□	28.5	57	34.5	69	45.4	107.5	16.5	103	32	50	6	7	20	59.5	25	31.2	82
LVQ4 ₂ -Z□□	28.5	57	34.5	69	45.4	113	22	114	37.5	55.5	6	7	20	59.5	25	31.2	87.5
LVQ5 ₂ -Z□□	42	84	48	96	75	153.2	25	150	50.2	78.2	10	7	20	73	38.5	45	128
LVQ6 ₂ -Z□□	42	84	48	96	75	163	32	167	60	88	10	7	20	73	38.5	45	137.5

Series LVQ-Z

Dimensions

With bypass

Double acting valve

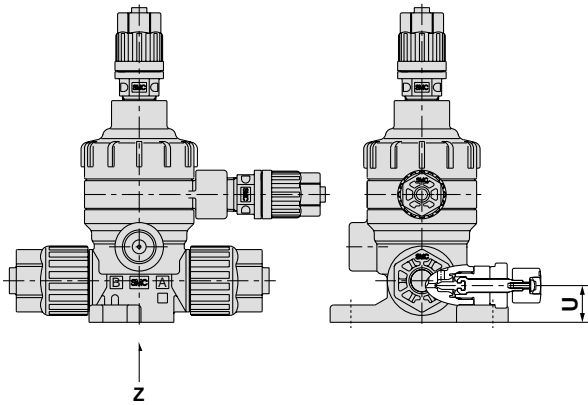
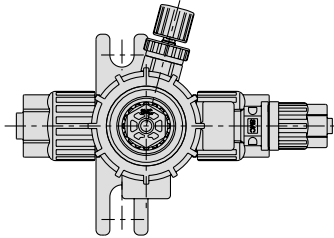

LVQ2¹₂

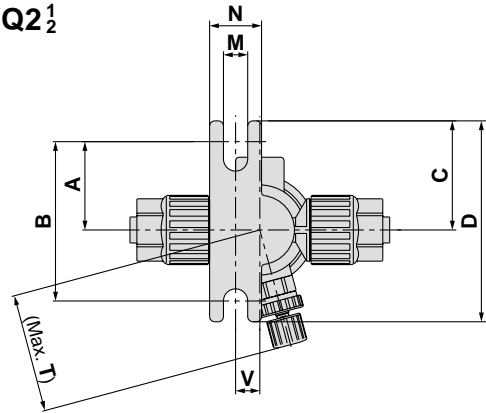

LVQ3¹₂, LVQ4¹₂
LVQ5¹₂, LVQ6¹₂

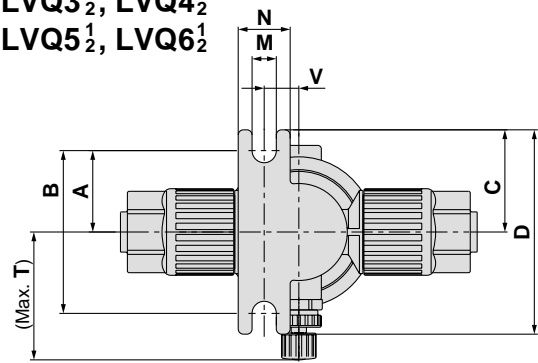

View Z

Dimensions (N.O valve, double acting valve)

(mm)

Model	A	B	C	D	M	N	T	U	V
LVQ2 ¹ ₂ -Z□□-2	25.5	46	31.5	58	7	15	34.3	10.6	7
LVQ3 ¹ ₂ -Z□□-2	25.5	51	31.5	63	7	15	36.9	16.5	10
LVQ4 ¹ ₂ -Z□□-2	25.5	51	31.5	63	7	15	37.9	22	10
LVQ5 ¹ ₂ -Z□□-2	38	76	44	88	7	20	64	25	17
LVQ6 ¹ ₂ -Z□□-2	38	76	44	88	7	20	66	32	17

Air Operated Type Flare Integral Fitting Type Space Saving/Space Saving Connection Series **LVQS-Z**

How to Order

LVQ **2** **0** **S** - **Z** **07** □ - □ - □

Body class

Symbol	Body class	Orifice dia.
2	2	ø4
3	3	ø8
4	4	ø10
5	5	ø16
6	6	ø22

Valve type

0	N.C.
1	N.O.
2	Double acting

Note) Refer to variations in the table below for valve type combinations.

Body type

S	Space saving connection
---	-------------------------

LQ3 integral fitting

Applicable fitting size

Symbol	Connecting tubing O.D.	Body class				
		2	3	4	5	6
07	1/4	○				
11	3/8		○			
13	1/2			○		
19	3/4				○	
25	1					○

Note) Refer to page 554 for How to order fitting parts. Select the fittings of the same size as the one at the valve side.

Option (2)

Symbol	Applicable option									Note	
	1	2	3	4	5	6	7	8	9		24
Nil	○	○	○	○	○	○	○	○	○	○	—
J	○	—	—	—	—	—	—	—	—	—	For high temperature
K	○	○	○	○	○	○	○	○	○	○	Buffer material FFKM
N	○	○	○	○	○	○	○	○	○	○	For ammonium hydroxide
P	—	—	—	○	○	—	—	—	—	—	High flow spec. LVQ6□ only

Pilot port thread type

Nil	LQ3 integral fitting	Connection tubing O.D. 1/8" (ø3)
M	LQ3 integral fitting	Connection tubing O.D. ø4
R	Threaded	Rc 1/8
N	Threaded	NPT 1/8

Option (1)

Nil	None	6	High back pressure with flow rate adjustment
1	With flow rate adjustment	7	High back pressure with bypass
2	With bypass	8	High back pressure with flow rate adjustment & bypass
3	With flow rate adjustment & bypass	9	High back pressure with indicator
4	With indicator	24	With indicator & bypass
5	High back pressure (0.42 MPa)		

Note) Options (2) cannot be combined with each other.

Note) Refer to variations in the table below for valve type and option (1) combinations. Options (1) can not be combined with each other.

Variations

Type	Symbol	Model	Orifice diameter				
			LVQ20S	LVQ30S	LVQ40S	LVQ50S	LVQ60S
			ø4	ø8	ø10	ø16	ø22
			2	3	4	5	6
Basic type N.C.		N.C.	○	○	○	○	○
N.O. Double acting		N.O. Double acting	○	○	○	○	○
With flow rate adjustment		N.C.	○	○	○	○	○
With bypass N.C.		N.C.	○	○	○	○	○
With flow rate adjustment & bypass		N.C.	○	○	○	○	○
With indicator		N.C.	○	○	○	○	○
High back pressure		N.C.	○	○	○	○	○
With indicator & bypass		N.C.	○	○	○	○	○

How to Order Fittings for Space Saving

LQ3 E 6A - S

• One nut of the nuts is not attached.

Type of fitting

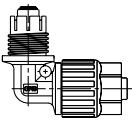
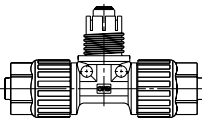
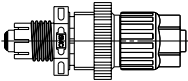
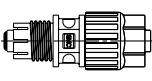
E	T
Union elbow 	Union tee 
P	U
Panel mount union 	Union 

• Applicable tubing size

Size	Symbol	Applicable tubing size (inch)
2	A	1/4" x 5/32"
3	A	3/8" x 1/4"
4	A	1/2" x 3/8"
5	A	3/4" x 5/8"
6	A	1" x 7/8"



Note 1) Select a fitting the same size as the valve fitting.

Piping example

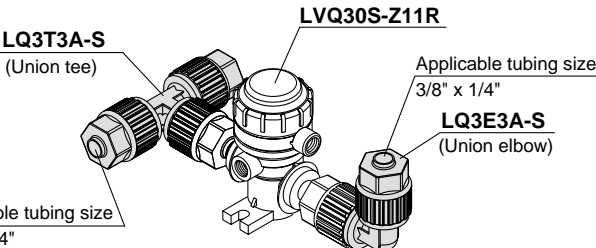

Applicable tubing size
3/8" x 1/4"

Example

LVQ30S-Z11R	1
LQ3T3A-S (Union tee)	1
LQ3E3A-S (Union elbow)	1

Note) For shipment, the valve and fittings are individually packaged and dispatched together in 1 box.

Standard Specifications



Model		LVQ20S	LVQ30S	LVQ40S	LVQ50S	LVQ60S
Connection fitting size		2	3	4	5	6
Orifice diameter		ø4	ø8	ø10	ø16	ø22
Flow characteristics	Av x 10 ⁻⁶ m ²	8.4	31.2	45.6	120	192 (228) ^{Note)}
	Cv	0.35	1.3	1.9	5	8 (9.5) ^{Note)}
Withstand pressure (MPa)		1				
Operating pressure <A→B flow>	Standard	-98 kPa to 0.5 MPa			-98 kPa to 0.4 MPa	
	High temperature	-98 kPa to 0.3 MPa				
Back pressure (MPa)	Standard	0.3 or less			0.2 or less	
	High back pressure	0.42 or less				
	High temperature	0.3 or less			0.2 or less	
Valve leakage (cm ³ /min)		0 (With water pressure)				
Pilot air pressure (MPa)		0.3 to 0.5 (High back pressure: 0.45 to 0.55)				
Pilot port size		1/8" (ø3), ø4, Rc 1/8, NPT 1/8				
Fluid temperature (°C)	Standard	0 to 100				
	High temperature	0 to 170				
Ambient temperature (°C)		0 to 60				
Mass (kg)		0.085	0.175	0.223	0.725	0.835

Note) () is high flow specification.

LVC

LVA

LVH

LVD

LVQ

LQ1

LVN

TL/TIL

LQ3

⚠ Specific Product Precautions

Be sure to read before handling. Refer to front matters 42 and 43 for Safety Instructions, and pages 585 and 586 for High Purity Chemical Valve Non-Metallic Exterior Precautions.

Piping

⚠ Caution

1. Tighten the nut to the end surface of the body. As a guide, refer to the proper tightening torques shown below.

Tightening torque for piping

Body class	Torque (N·m)
2	1.6 to 1.8
3	3.2 to 3.5
4	5.0 to 5.3
5	10.0 to 10.5
6	22.5 to 23.0

Series LVQS-Z

Construction

Basic type

N.C. type

N.O. type

Double acting type

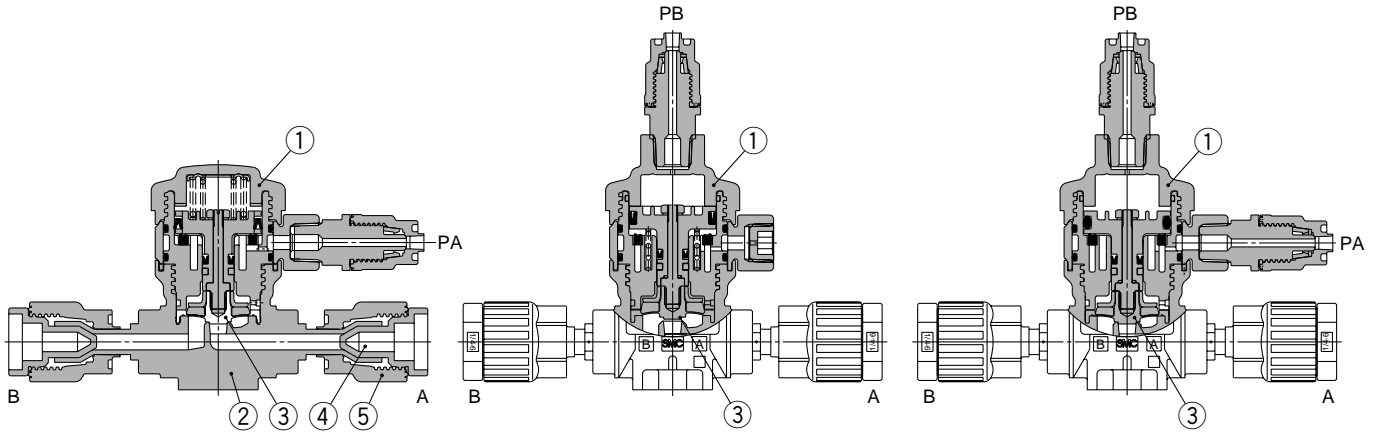

With flow rate adjustment

With bypass

With indicator

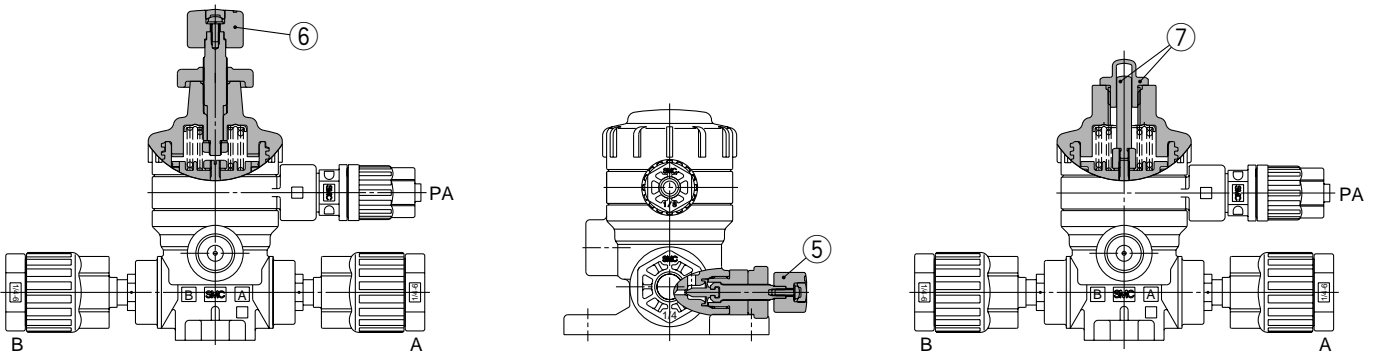

Parts list

No.	Description	Material
1	Actuator section	PVDF
2	Body	PFA
3	Diaphragm	PTFE
4	Plug	PFA
5	Nut	PFA
6	Flow rate adjuster section	PVDF
7	Indicator, cover	PP

Dimensions

Basic type, High back pressure spec.

N.C. valve

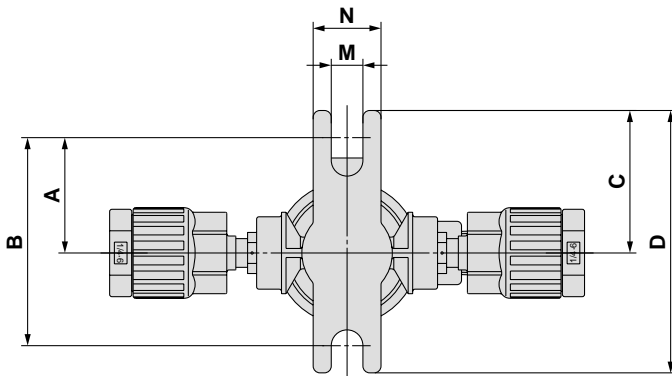
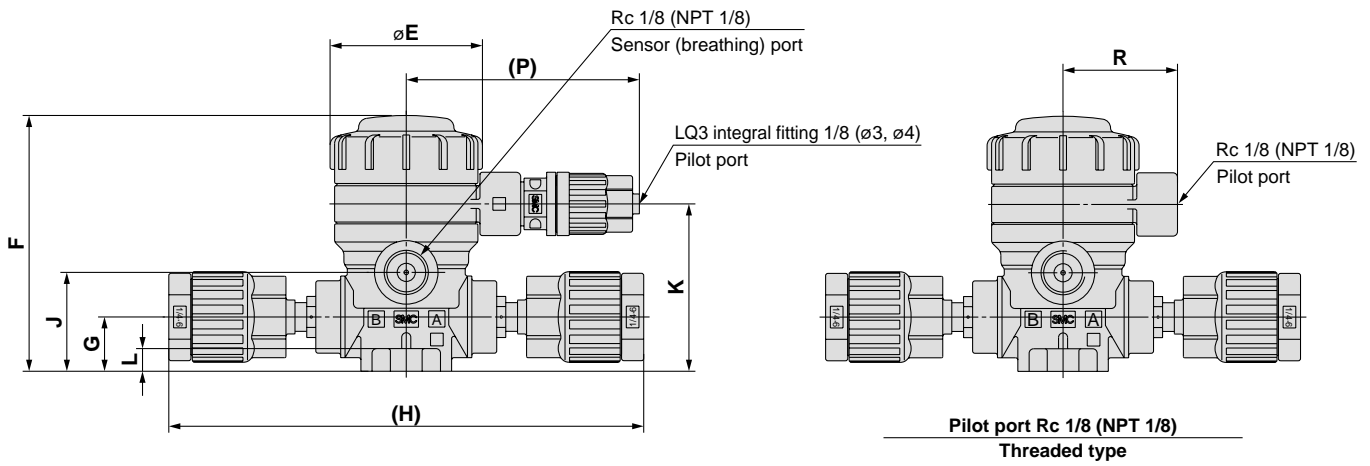
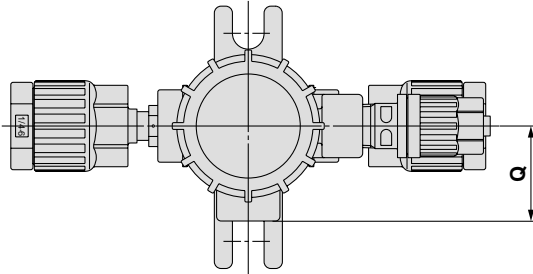

LVC

LVA

LVH

LVD

LVQ

LQ1

LVN

TL/TIL

LQ3

LVQ□0S-Z□ Dimensions (N.C. valve)

(mm)

Model	A	B	C	D	E	F	G	H	J	K	L	M	N	P	Q	R
LVQ20S-Z□	25.5	46	31.5	58	33.6	56.5	12	105	21.8	37	5	7	15	53.5	21	25.3
LVQ30S-Z□	28.5	57	34.5	69	45.4	77	16.5	137	32	50	6	7	20	59.5	25	31.2
LVQ40S-Z□	28.5	57	34.5	69	45.4	82.5	22	151	37.5	55.5	6	7	20	59.5	25	31.2
LVQ50S-Z□	42	84	48	96	75	127	25	202	50.2	78.2	10	7	20	73	38.5	45
LVQ60S-Z□	42	84	48	96	75	136.8	32	236	60	88	10	7	20	73	38.5	45

Series LVQS-Z

Dimensions

With flow rate adjustment, High back pressure spec. with flow rate adjustment
N.C. valve

Dimensions (mm)	
Model	S
LVQ20S-Z□-1	83
LVQ30S-Z□-1	113.5
LVQ40S-Z□-1	119
LVQ50S-Z□-1	171.5
LVQ60S-Z□-1	182.5

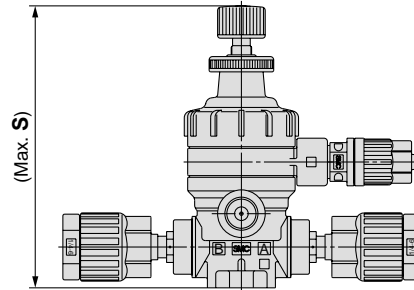

With bypass, High back pressure spec. with bypass
N.C. valve

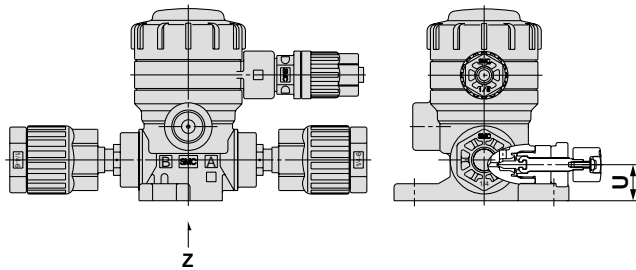
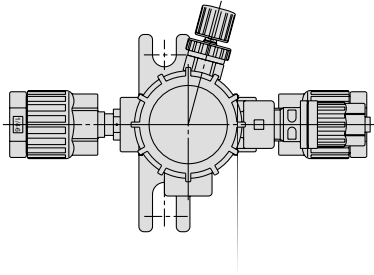

LVQ20S

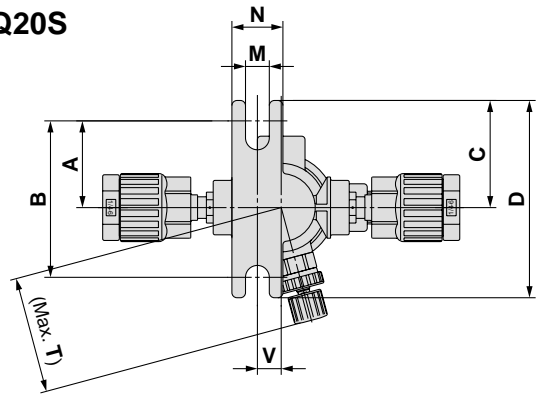

LVQ30S, LVQ40S
LVQ50S, LVQ60S

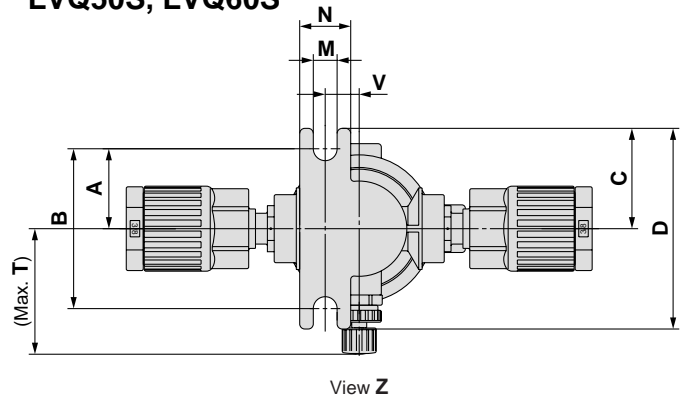

Dimensions (mm)									
Model	A	B	C	D	M	N	T	U	V
LVQ20S-Z□-2	25.5	46	31.5	58	7	15	34.3	10.6	7
LVQ30S-Z□-2	25.5	51	31.5	63	7	15	36.9	16.5	10
LVQ40S-Z□-2	25.5	51	31.5	63	7	15	37.9	22	10
LVQ50S-Z□-2	38	76	44	88	7	20	64	25	17
LVQ60S-Z□-2	38	76	44	88	7	20	66	32	17

With flow rate adjustment & bypass
High back pressure spec.
with flow rate adjustment & bypass
N.C. valve

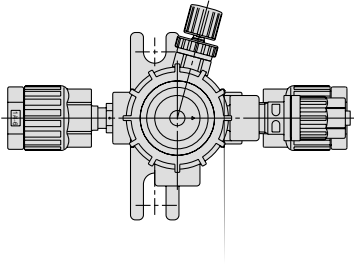

LVQ20S

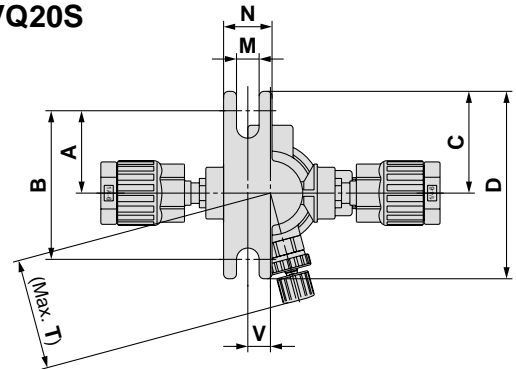

LVC

LVA

LVH

LVD

LVQ

LQ1

LVN

TL/TIL

LQ3

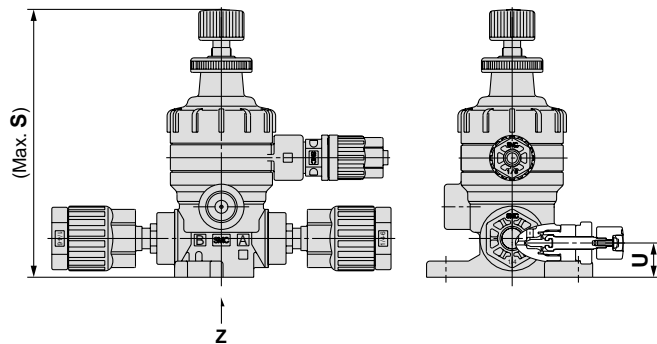

LVQ30S, LVQ40S
LVQ50S, LVQ60S

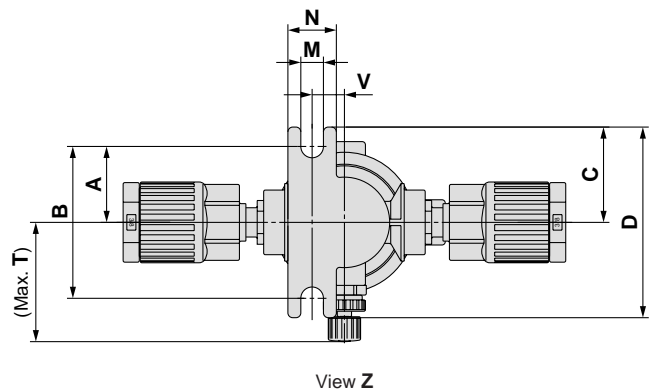

Dimensions (mm)

Model	A	B	C	D	M	N	S	T	U	V
LVQ20S-Z□-3	25.5	46	31.5	58	7	15	83	34.3	10.6	7
LVQ30S-Z□-3	25.5	51	31.5	63	7	15	113.5	36.9	16.5	10
LVQ40S-Z□-3	25.5	51	31.5	63	7	15	119	37.9	22	10
LVQ50S-Z□-3	38	76	44	88	7	20	171.5	64	25	17
LVQ60S-Z□-3	38	76	44	88	7	20	182.5	66	32	17

With indicator, High back pressure spec. with indicator
N.C. valve

Dimensions (mm)

Model	S
LVQ20S-Z□-4	70.5
LVQ30S-Z□-4	88.5
LVQ40S-Z□-4	94
LVQ50S-Z□-4	134.5
LVQ60S-Z□-4	144

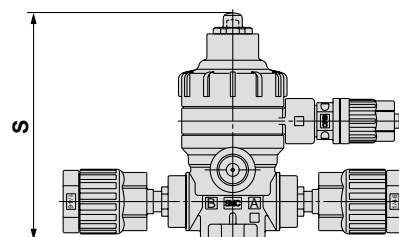

Series LVQS-Z

Dimensions

Basic type N.O. valve

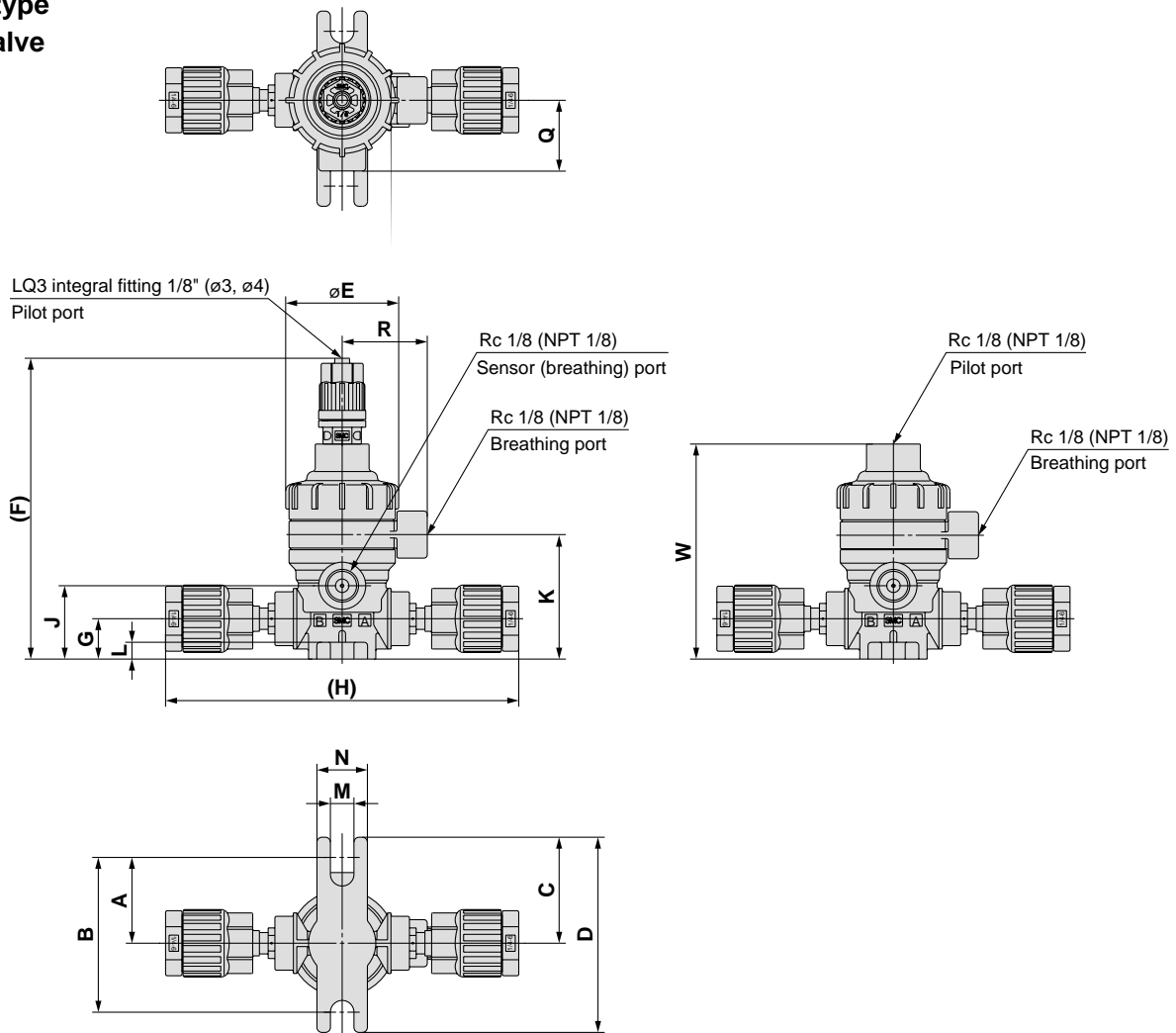

Double acting valve

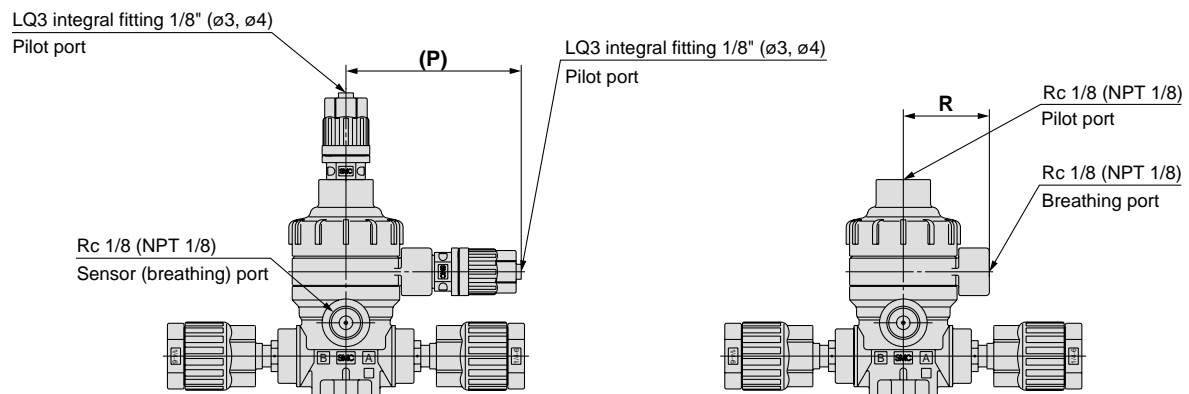

LVQ□¹/₂S-Z□ Dimensions (N.O. valve, double acting valve)

(mm)

Model	A	B	C	D	E	F	G	H	J	K	L	M	N	P	Q	R	W
LVQ2 ¹ / ₂ S-Z□	25.5	46	31.5	58	33.6	89.5	12	105	21.8	37	5	7	15	53.5	21	25.3	64
LVQ3 ¹ / ₂ S-Z□	28.5	57	34.5	69	45.4	107.5	16.5	137	32	50	6	7	20	59.5	25	31.2	82
LVQ4 ¹ / ₂ S-Z□	28.5	57	34.5	69	45.4	113	22	151	37.5	55.5	6	7	20	59.5	25	31.2	87.5
LVQ5 ¹ / ₂ S-Z□	42	84	48	96	75	153.2	25	202	50.2	78.2	10	7	20	73	38.5	45	128
LVQ6 ¹ / ₂ S-Z□	42	84	48	96	75	163	32	236	60	88	10	7	20	73	38.5	45	137.5

With bypass
Double acting valve

LVQ2 $\frac{1}{2}$ S

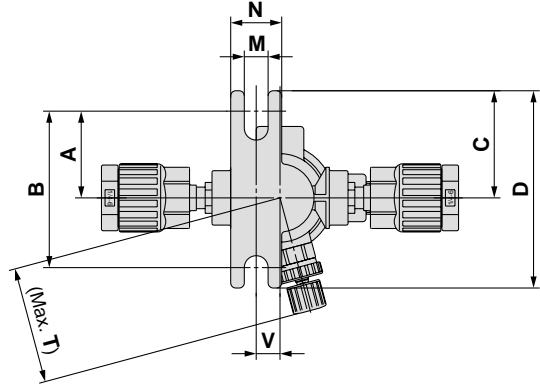
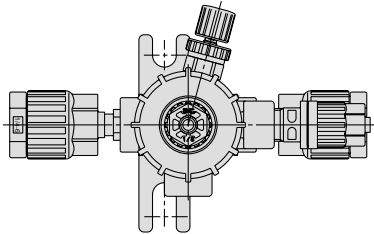

LVQ3 $\frac{1}{2}$ S, LVQ4 $\frac{1}{2}$ S
LVQ5 $\frac{1}{2}$ S, LVQ6 $\frac{1}{2}$ S

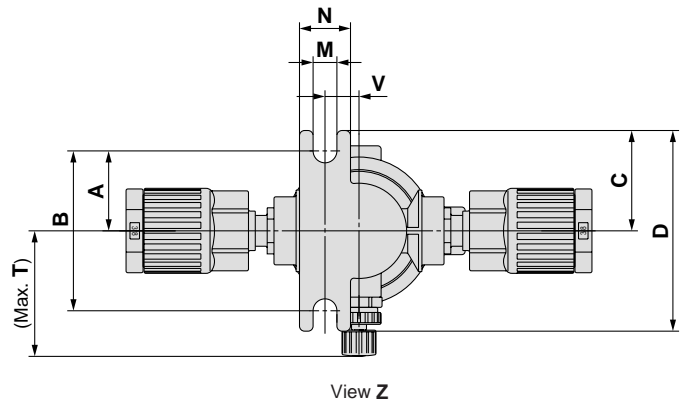
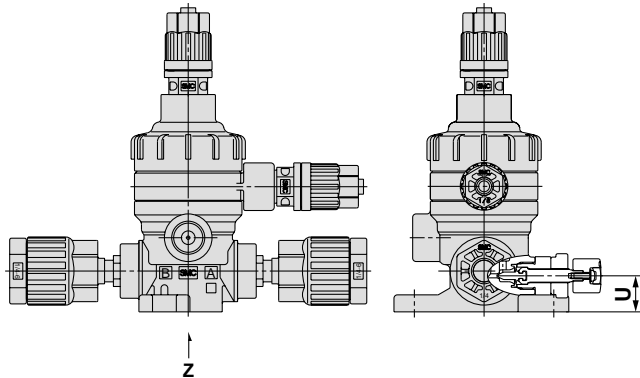

LVC

LVA

LVH

LVD

LVQ

LQ1

LVN

TL/TIL

LQ3

Dimensions (N.O. valve, double acting valve)

(mm)

Model	A	B	C	D	M	N	T	U	V
LVQ2 $\frac{1}{2}$ -S-Z□-2	25.5	46	31.5	58	7	15	34.3	10.6	7
LVQ3 $\frac{1}{2}$ -S-Z□-2	25.5	51	31.5	63	7	15	36.9	16.5	10
LVQ4 $\frac{1}{2}$ -S-Z□-2	25.5	51	31.5	63	7	15	37.9	22	10
LVQ5 $\frac{1}{2}$ -S-Z□-2	38	76	44	88	7	20	64	25	17
LVQ6 $\frac{1}{2}$ -S-Z□-2	38	76	44	88	7	20	66	32	17

Manual Type Flare Integral Fitting Type Hyper Fittings Series **LVQH-Z**

How to Order

LVQH **2** 0 - Z **07** - **1** -

Body class

Symbol	Body class	Orifice dia.
2	2	ø4
3	3	ø8
4	4	ø10
5	5	ø16
6	6	ø22

Option

Symbol	Note
Nil	Standard
K	Buffer material FFKM
N	For ammonium hydroxide



Note) Options cannot be combined with each other.

LQ3 integral fittings

Applicable tubing size

Symbol	Connecting tubing O.D.	Body class					
		2	3	4	5	6	
Metric sizes							
03	ø3	○					
04	ø4	○					
06	ø6	○					
08	ø8		○				
10	ø10		○				
12	ø12			○			
19	ø19				○		
25	ø25					○	
Inch sizes							
03	1/8	○					
07	1/4	○					
11	3/8		○				
13	1/2			○			
19	3/4				○		
25	1					○	

Handle operation

1	90 Degree turn type
4	Multi-turn type (with indicator)

Breathing port thread type

Nil	Threaded	NPT 1/8
R	Threaded	Rc 1/8

Variations

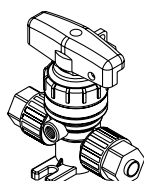
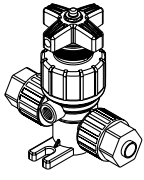
Type	Symbol	Model				
		LVQH20	LVQH30	LVQH40	LVQH50	LVQH60
		Orifice diameter				
Tubing outside dia.		Millimeter				
		Inch				
90 Degree turn type		ø4	ø8	ø10	ø16	ø22
		6	10	12	19	25
		1/4	3/8	1/2	3/4	1
		○	○	○	○	○
		○	○	○	○	○

Standard Specifications



Model		LVQH20	LVQH30	LVQH40	LVQH50	LVQH60
Tubing O.D.	Metric size	6	10	12	19	25
	Inch size	1/4	3/8	1/2	3/4	1
Orifice diameter		ø4	ø8	ø10	ø16	ø22
Flow characteristics	Av x 10 ⁻⁶ m ²	8.4	31.2	45.6	120	192 (228) ^{Note)}
	Cv	0.35	1.3	1.9	5	8 (9.5) ^{Note)}
Withstand pressure (MPa)		1				
Operating pressure <A→B flow>		-98 kPa to 0.5 MPa			-98 kPa to 0.4 MPa	
Back pressure (MPa)		0.3 or less			0.2 or less	
Valve leakage (cm ³ /min)		0 (With water pressure)				
Fluid temperature (°C)		0 to 100				
Ambient temperature (°C)		0 to 60				
Mass (kg)	LVQH□0-1	0.12	0.27	0.32	1.14	1.20
	LVQH□0-4	0.11	0.25	0.23	0.72	0.82

Note) () is high flow specification.

LVC

LVA

LVH

LVD

LVQ

LQ1

LVN

TL/TIL

LQ3

⚠ Specific Product Precautions

Be sure to read before handling. Refer to front matters 42 and 43 for Safety Instructions, and pages 585 and 586 for High Purity Chemical Valve Non-Metallic Exterior Precautions.

Piping

⚠ Caution

1. Connect tubing with special tools.

Refer to the pamphlet "High-Purity Fluoropolymer Fittings HYPER FITTING®/Flare Type Series LQ3 Fitting Procedure" (M-E06-4) for connecting tubing and special tools. (Downloadable from our web site.)

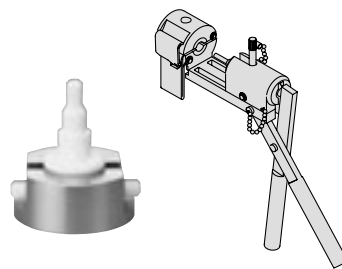

2. Tighten the nut to the end surface of the body. As a guide, refer to the proper tightening torques shown below.

Tightening torque for piping

Body class	Torque (N·m)
2	1.6 to 1.8
3	3.2 to 3.5
4	5.0 to 5.3
5	10.0 to 10.5
6	22.5 to 23.0

Series LVQH-Z

Construction

90 Degree turn type

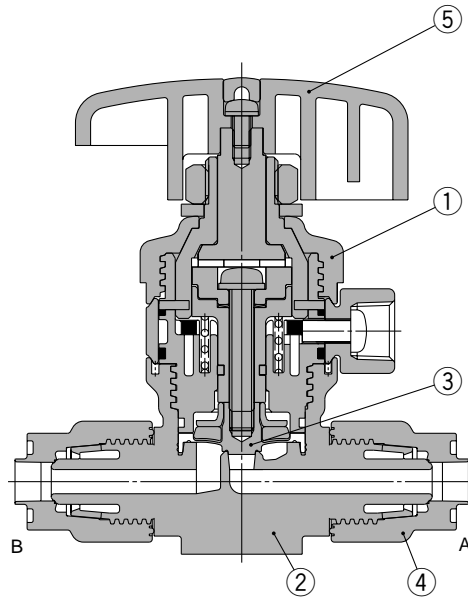

Multi-turn type (with indicator)

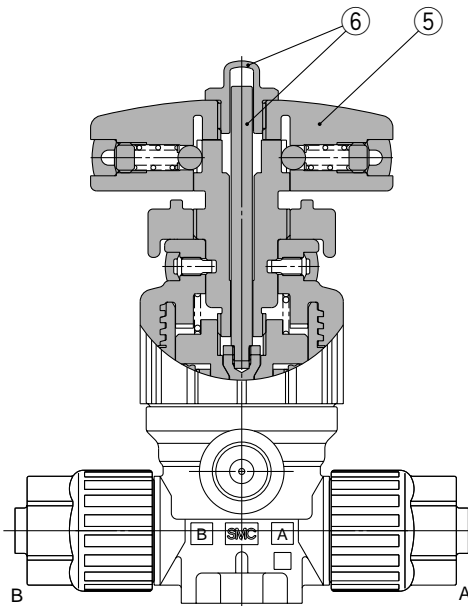

Parts list

No.	Description	Material
1	Actuator section	PVDF
2	Body	PFA
3	Diaphragm	PTFE
4	Nut	PFA
5	Handle section	PVDF
6	Indicator, cover	PP

Dimensions

90 Degree turn type

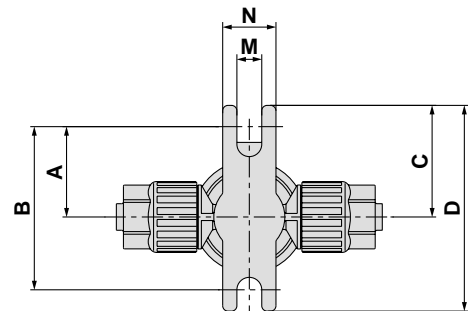
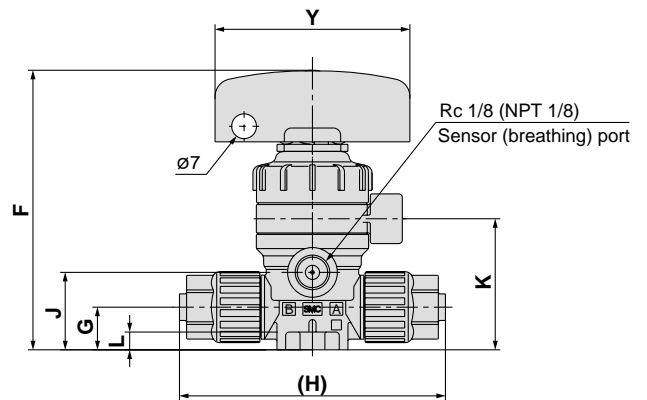
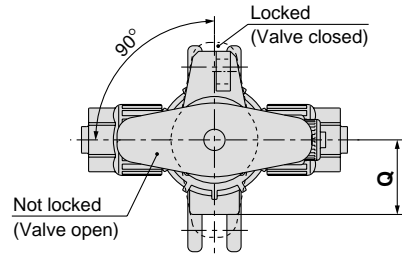

Dimensions

(mm)

Model	A	B	C	D	F	G	H
LVQH20-Z□□-1	25.5	46	31.5	58	79	12	75
LVQH30-Z□□-1	28.5	57	34.5	69	103	16.5	103
LVQH40-Z□□-1	28.5	57	34.5	69	108	22	114
LVQH50-Z□□-1	42	84	48	96	165	25	150
LVQH60-Z□□-1	42	84	48	96	175	32	167

Model	J	K	L	M	N	Q	Y
LVQH20-Z□□-1	21.8	37	5	7	15	21	55
LVQH30-Z□□-1	32	50	6	7	20	25	80
LVQH40-Z□□-1	37.5	55.5	6	7	20	25	80
LVQH50-Z□□-1	50.2	78.2	10	7	20	38.5	110
LVQH60-Z□□-1	60	88	10	7	20	38.5	110

Multi-turn type (with indicator)

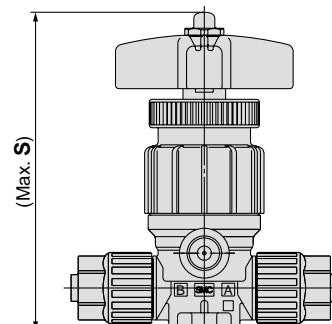
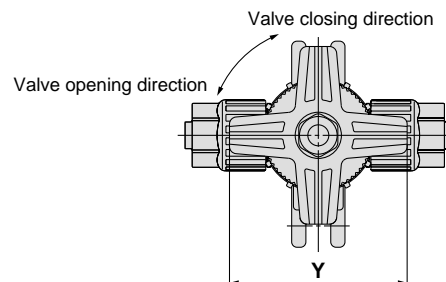

Dimensions

(mm)

Model	S	Y
LVQH20-Z□-4	89.6	50
LVQH30-Z□-4	107.2	50
LVQH40-Z□-4	112.7	50
LVQH50-Z□-4	165	71
LVQH60-Z□-4	174.5	71

LVC

LVA

LVH

LVD

LVQ

LQ1

LVN

TL/TIL

LQ3

Manual Type Flare Integral Fitting Type Space Saving/Space Saving Connection Series **LVQHS-Z**

How to Order

LVQH **2** **0** **S** - **Z** **07** **□** - **1** - **□**

Body class

Symbol	Body class	Orifice dia.
2	2	ø4
3	3	ø8
4	4	ø10
5	5	ø16
6	6	ø22

Body type

S	Space saving connection
----------	-------------------------

LQ3 integral fittings

Option

Symbol	Note
Nil	Standard
K	Buffer material FFKM
N	For ammonium hydroxide



Note) Options cannot be combined with each other.

Handle operation

1	90 Degree turn type
4	Multi-turn type (with indicator)

Breathing port thread type

Nil	Threaded	NPT 1/8
R	Threaded	Rc 1/8



Applicable fitting size

Symbol	Connecting tubing O.D.	Body class				
		2	3	4	5	6
Inch sizes						
07	1/4	○				
11	3/8		○			
13	1/2			○		
19	3/4				○	
25	1					○

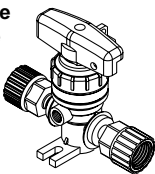
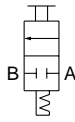
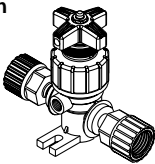

Note) Refer to page 567 for How to order fitting parts.
Select the fittings of the same size as the one at the valve side.

Variations

Type	Model	Orifice diameter	Connection fitting size	Symbol	LVQ20S	LVQ30S	LVQ40S	LVQ50S	LVQ60S		
							○	○	○	○	○
								○	○	○	○

How to Order Fittings for Space Saving

LQ3 E 6A - S

• One nut of the nuts is not attached.

Type of fitting

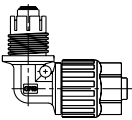
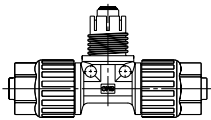
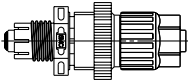
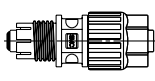
E	T
Union elbow 	Union tee 
P	U
Panel mount union 	Union 

• Applicable tubing size

Size	Symbol	Applicable tubing size (inch)
2	A	1/4" x 5/32"
3	A	3/8" x 1/4"
4	A	1/2" x 3/8"
5	A	3/4" x 5/8"
6	A	1" x 7/8"

Note 1) Select a fitting the same size as the valve fitting.

LVC

LVA

LVH

LVD

LVQ

LQ1

LVN

TL/TIL

LQ3

Piping example

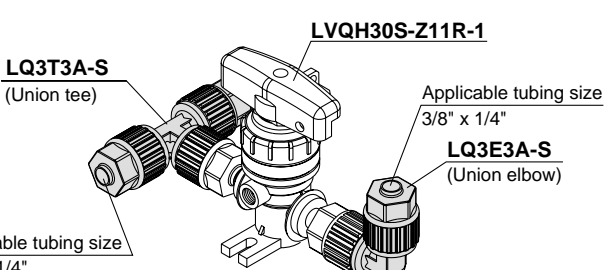

LQ3T3A-S
(Union tee)

LVQH30S-Z11R-1

Applicable tubing size
3/8" x 1/4"

LQ3E3A-S
(Union elbow)

Applicable tubing size
3/8" x 1/4"

Example

LVQH30S-Z11R-1	1
LQ3T3A-S (Union tee)	1
LQ3E3A-S (Union elbow)	1

Note) For shipment, the valve and fittings are individually packaged and dispatched together in 1 box.



Standard Specifications

Model		LVQH20S	LVQH30S	LVQH40S	LVQH50S	LVQH60S
Connection fitting size		2	3	4	5	6
Orifice diameter		ø4	ø8	ø10	ø16	ø22
Flow characteristics	Av x 10 ⁻⁶ m ²	8.4	31.2	45.6	120	192 (228) ^{Note)}
	Cv	0.35	1.3	1.9	5	8 (9.5) ^{Note)}
Withstand pressure (MPa)		1				
Operating pressure <A→B flow>		-98 kPa to 0.5 MPa			-98 kPa to 0.4 MPa	
Back pressure (MPa)		0.3 or less			0.2 or less	
Valve leakage (cm ³ /min)		0 (With water pressure)				
Fluid temperature (°C)		0 to 100				
Ambient temperature (°C)		0 to 60				
Mass (kg)	LVQH□0S-1	0.14	0.28	0.34	1.14	1.15
	LVQH□S0-4	0.13	0.21	0.25	0.72	0.86

Note) () is high flow specification.

⚠ Specific Product Precautions

Be sure to read before handling. Refer to front matters 42 and 43 for Safety Instructions, and pages 585 and 586 for High Purity Chemical Valve Non-Metallic Exterior Precautions.

Piping

⚠ Caution

1. Tighten the nut to the end surface of the body. As a guide, refer to the proper tightening torques shown below.

Tightening torque for piping

Body class	Torque (N·m)
2	1.6 to 1.8
3	3.2 to 3.5
4	5.0 to 5.3
5	10.0 to 10.5
6	22.5 to 23.0

Construction

90 Degree turn type

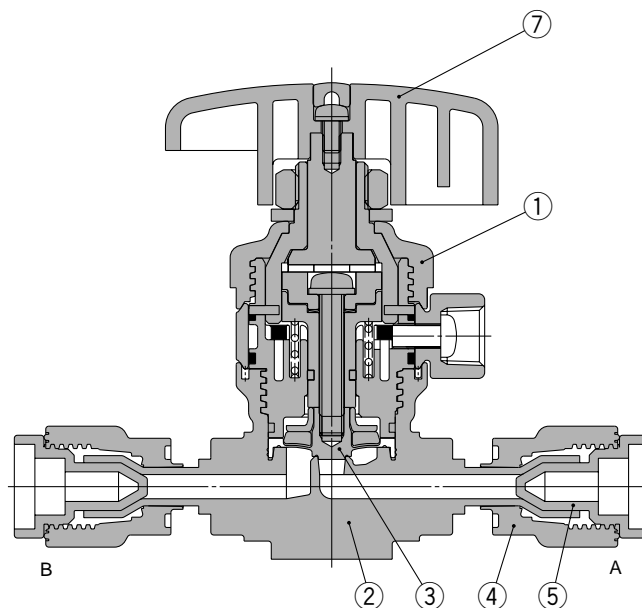

LVC

LVA

LVH

LVD

LVQ

LQ1

LVN

TL/TIL

LQ3

Multi-turn type (with indicator)

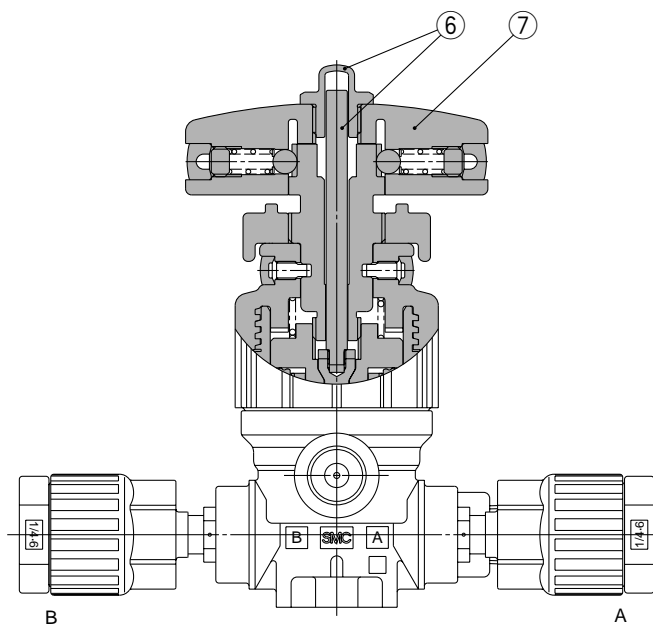

Parts list

No.	Description	Material
1	Actuator section	PVDF
2	Body	PFA
3	Diaphragm	PTFE
4	Nut	PFA
5	Plug	PFA
6	Indicator, cover	PP
7	Handle section	PVDF

Series LVQHS-Z

Dimensions

90 Degree turn type

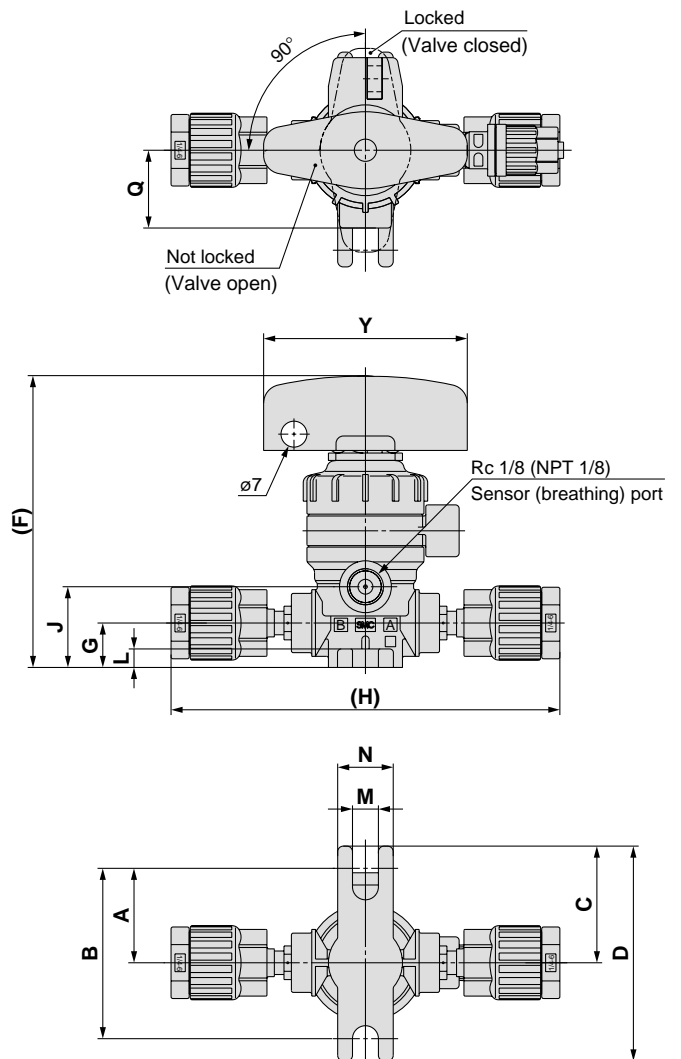

Dimensions (mm)

Model	A	B	C	D	F	G	H
LVQH20S-Z□-1	25.5	46	31.5	58	79	12	105
LVQH30S-Z□-1	28.5	57	34.5	69	103	16.5	137
LVQH40S-Z□-1	28.5	57	34.5	69	108	22	151
LVQH50S-Z□-1	42	84	48	96	165	25	202
LVQH60S-Z□-1	42	84	48	96	175	32	236

Model	J	K	L	M	N	Q	Y
LVQH20S-Z□-1	21.8	37	5	7	15	21	55
LVQH30S-Z□-1	32	50	6	7	20	25	80
LVQH40S-Z□-1	37.5	55.5	6	7	20	25	80
LVQH50S-Z□-1	50.2	78.2	10	7	20	38.5	110
LVQH60S-Z□-1	60	88	10	7	20	38.5	110

Multi-turn type (with indicator)

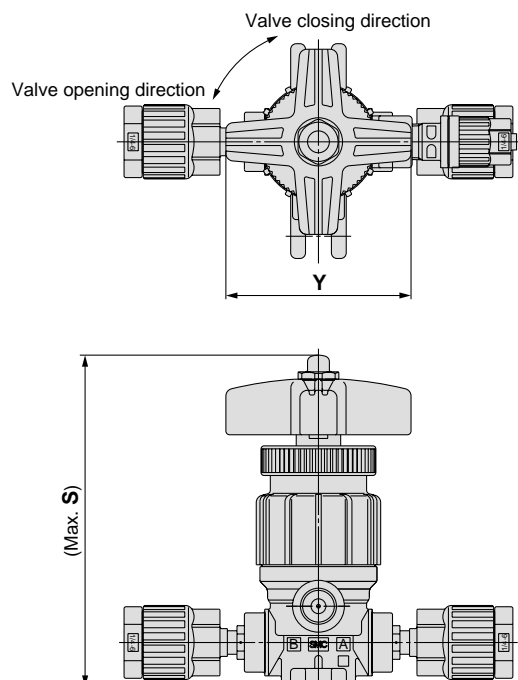

Dimensions (mm)

Model	S	Y
LVQH20S-Z□-4	89.6	50
LVQH30S-Z□-4	107.2	50
LVQH40S-Z□-4	112.7	50
LVQH50S-Z□-4	165	71
LVQH60S-Z□-4	174.5	71

Air Operated Type Tube Extension Fitting Type Series **LVQ-T**

How to Order

LVQ **2** **0** - T **07** - -

Body class

Symbol	Body class	Orifice dia.
2	2	ø4
3	3	ø8
4	4	ø10
5	5	ø16
6	6	ø22

Valve type

0	N.C.
1	N.O.
2	Double acting

Note) Refer to variations in the table below for valve type combinations.

Tube Extension Fitting

Applicable tubing size

Symbol	Connecting tubing O.D.	Body class					
		2	3	4	5	6	
Metric sizes							
06	ø6	○					
10	ø10		○				
12	ø12			○			
19	ø19				○		
25	ø25					○	
Inch sizes							
07	1/4	○					
11	3/8		○				
13	1/2			○			
19	3/4				○		
25	1					○	

Pilot port thread type

Nil	LQ1 integral fitting	Connection tubing O.D. 1/8" (ø3)
M	LQ1 integral fitting	Connection tubing O.D. ø4
R	Threaded	Rc 1/8
N	Threaded	NPT 1/8

Option (2)

Symbol	Applicable option										Note	
	1	2	3	4	5	6	7	8	9	24		
Nil	○	○	○	○	○	○	○	○	○	○	—	—
J	○	—	—	—	—	—	—	—	—	—	—	For high temperature
K	○	○	○	○	○	○	○	○	○	○	○	Buffer material FFKM
N	○	○	○	○	○	○	○	○	○	○	○	For ammonium hydroxide
P	—	—	—	○	○	—	—	—	—	—	—	High flow spec. LVQ6□ only

Option (1)

Nil	None	5	High back pressure (0.42 MPa)
1	With flow rate adjustment	6	High back pressure with flow rate adjustment
2	With bypass	7	High back pressure with bypass
3	With flow rate adjustment & bypass	8	High back pressure with flow rate adjustment & bypass
4	With indicator	9	High back pressure with indicator

Note) Options (2) cannot be combined with each other.

Note) Refer to variations in the table below for valve type and option (1) combinations. Options (1) can not be combined with each other.

Variations

Type	Symbol	Model	Orifice diameter									
			LVQ20	LVQ30	LVQ40	LVQ50	LVQ60					
			ø4	ø8	ø10	ø16	ø22					
		Tubing outside dia.		Valve type								
		Millimeter		Inch								
		6		1/4								
		10		3/8								
		12		1/2								
		19		3/4								
		25		1								
Basic type												
N.C.		N.C.	○	○	○	○	○					
N.O.		N.O.	○	○	○	○	○					
Double acting		Double acting	○	○	○	○	○					
With flow rate adjustment												
N.C.		N.C.	○	○	○	○	○					
With bypass												
N.C.		N.C.	○	○	○	○	○					
Double acting		Double acting	○	○	○	○	○					
With flow rate adjustment & bypass												
N.C.		N.C.	○	○	○	○	○					
With indicator												
N.C.		N.C.	○	○	○	○	○					
High back pressure												
N.C.		N.C.	○	○	○	○	○					

Series LVQ-T



Standard Specifications

Model		LVQ20	LVQ30	LVQ40	LVQ50	LVQ60
Tubing O.D.	Metric size	6	10	12	19	25
	Inch size	1/4	3/8	1/2	3/4	1
Orifice diameter		ø4	ø8	ø10	ø16	ø22
Flow characteristics	$Av \times 10^{-6} m^2$	8.4	31.2	45.6	120	192 (228) ^{Note)}
	Cv	0.35	1.3	1.9	5	8 (9.5) ^{Note)}
Withstand pressure (MPa)		1				
Operating pressure <A→B flow>	Standard	-98 kPa to 0.5 MPa			-98 kPa to 0.4 MPa	
	High temperature	-98 kPa to 0.3 MPa				
Back pressure (MPa)	Standard	0.3 or less			0.2 or less	
	High back pressure	0.42 or less				
	High temperature	0.3 or less			0.2 or less	
Valve leakage (cm ³ /min)		0 (With water pressure)				
Pilot air pressure (MPa)		0.3 to 0.5 (High back pressure: 0.45 to 0.55)				
Pilot port size		1/8" (ø3), ø4, Rc 1/8, NPT 1/8				
Fluid temperature (°C)	Standard	0 to 100				
	High temperature	0 to 170				
Ambient temperature (°C)		0 to 60				
Mass (kg)		0.08	0.15	0.16	0.60	0.70

Note) () is high flow specification.

Construction

Basic type

N.C. type

N.O. type

Double acting type

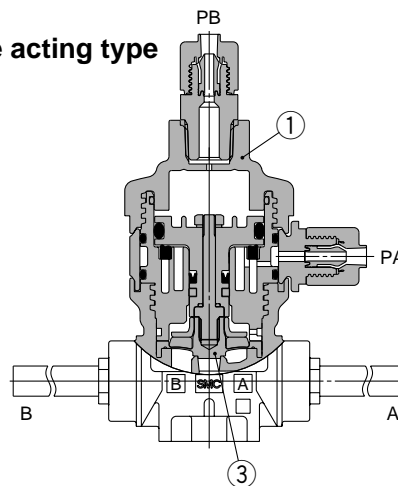
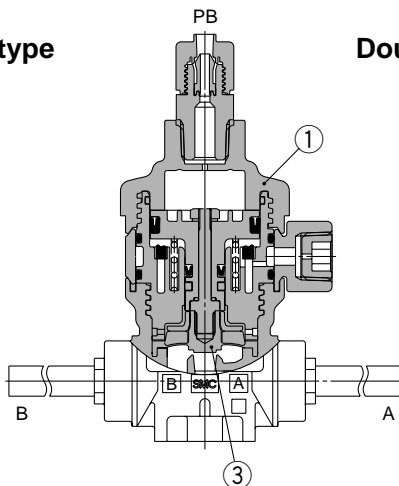
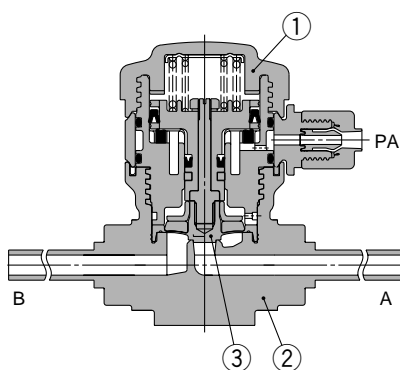

With flow rate adjustment

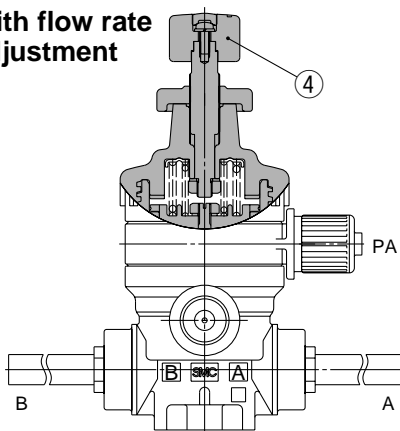

With bypass

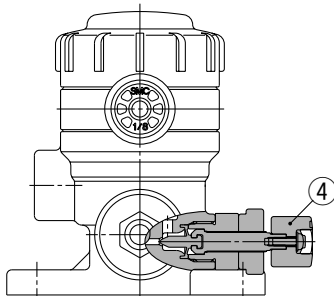

With indicator

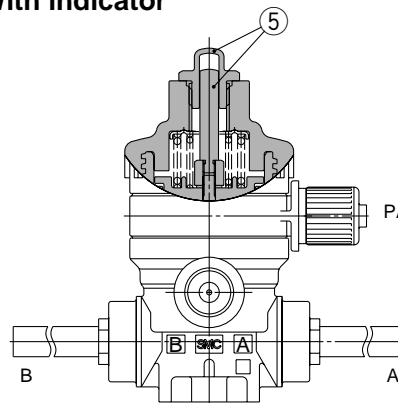

Parts list

No.	Description	Material
1	Actuator section	PVDF
2	Body	PFA
3	Diaphragm	PTFE
4	Flow rate adjuster section	PVDF
5	Indicator, cover	PP

Dimensions

Basic type, High back pressure spec.
N.C. valve

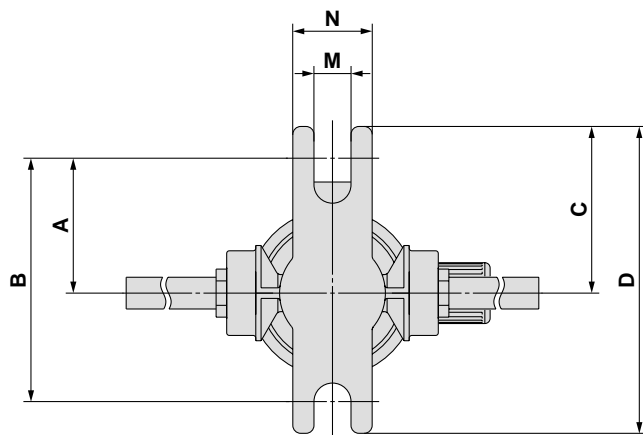
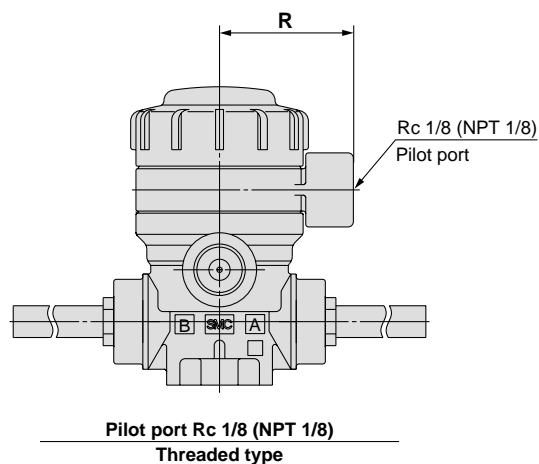
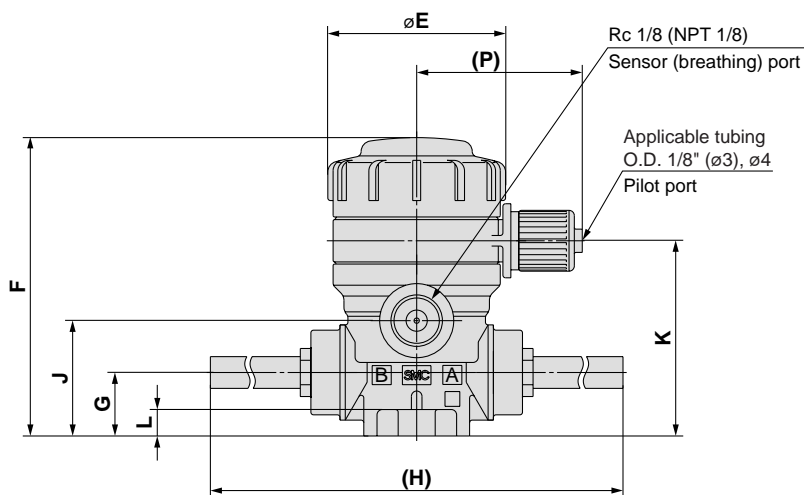
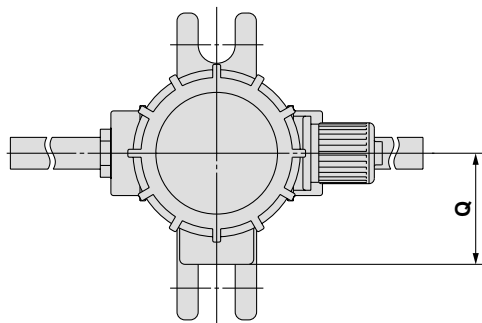

- LVC
- LVA
- LVH
- LVD
- LVQ**
- LQ1
- LVN
- TL/TIL
- LQ3

LVQ□0-T□ Dimensions (N.C. valve)

(mm)

Model	A	B	C	D	E	F	G	H	J	K	L	M	N	P	Q	R
LVQ20-T□	25.5	46	31.5	58	33.6	56.5	12	111.5	21.8	37	5	7	15	31.3	21	25.3
LVQ30-T□	28.5	57	34.5	69	45.4	77	16.5	136	32	50	6	7	20	37.2	25	31.2
LVQ40-T□	28.5	57	34.5	69	45.4	82.5	22	137	37.5	55.5	6	7	20	37.2	25	31.2
LVQ50-T□	42	84	48	96	75	127	25	180	50.2	78.2	10	7	20	50.8	38.5	45
LVQ60-T□	42	84	48	96	75	137	32	189	60	88	10	7	20	50.8	38.5	45

Series LVQ-T

Dimensions

With flow rate adjustment, High back pressure spec. with flow rate adjustment
N.C. valve

Dimensions (mm)	
Model	S
LVQ20-T□-1	83
LVQ30-T□-1	113.5
LVQ40-T□-1	119
LVQ50-T□-1	171.5
LVQ60-T□-1	182.5

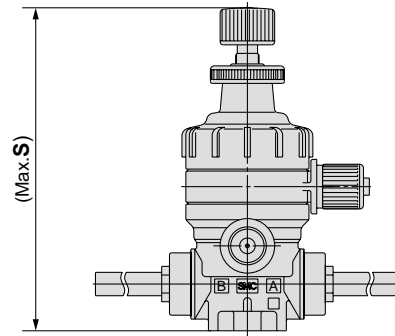

With bypass, High back pressure spec. with bypass
N.C. valve

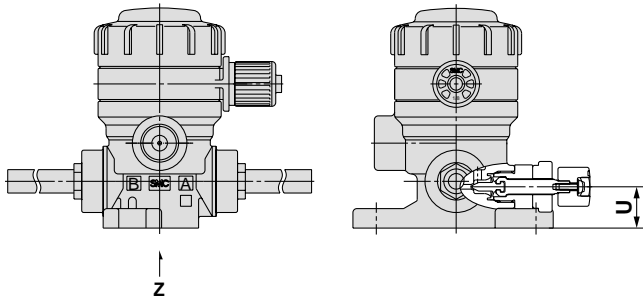
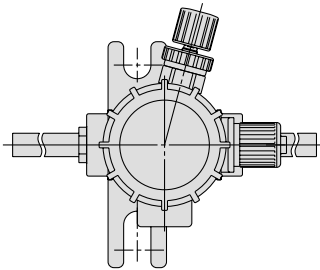

LVQ20

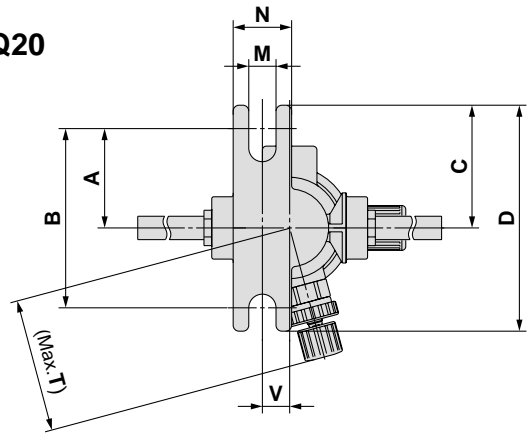

LVQ30, LVQ40
LVQ50, LVQ60

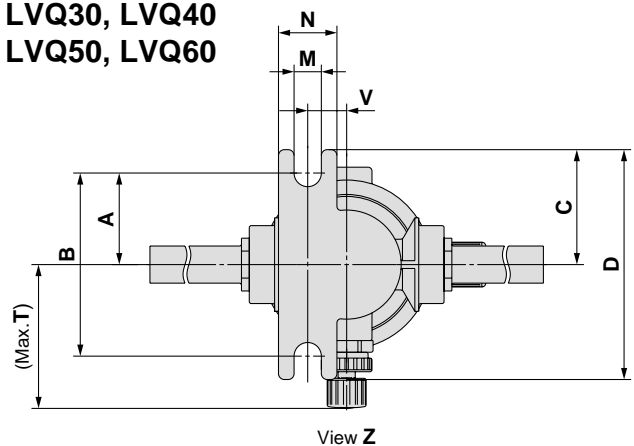

Dimensions (mm)									
Model	A	B	C	D	M	N	T	U	V
LVQ20-T□-2	25.5	46	31.5	58	7	15	34.3	10.6	7
LVQ30-T□-2	25.5	51	31.5	63	7	15	36.9	16.5	10
LVQ40-T□-2	25.5	51	31.5	63	7	15	37.9	22	10
LVQ50-T□-2	38	76	44	88	7	20	64	25	17
LVQ60-T□-2	38	76	44	88	7	20	66	32	17

With flow rate adjustment & bypass
High back pressure spec. with flow rate
adjustment & bypass
N.C. valve

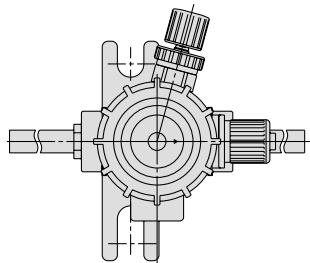

LVQ20

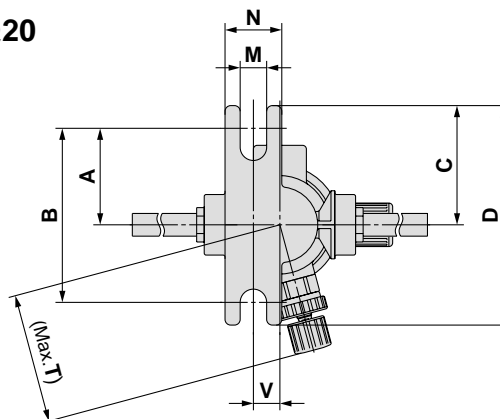

- LVC
- LVA
- LVH
- LVD
- LVQ**
- LQ1
- LVN
- TL/TIL
- LQ3

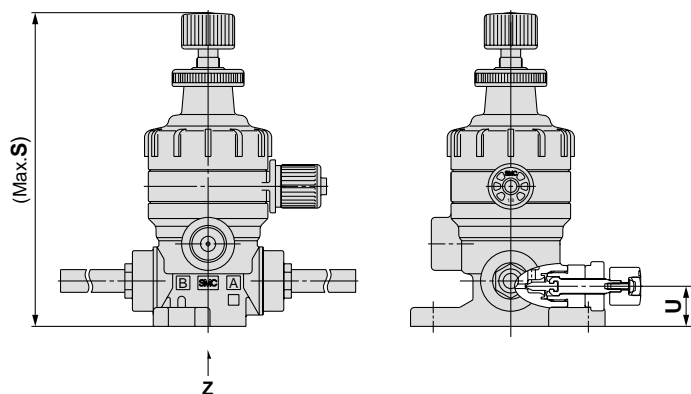

LVQ30, LVQ40
LVQ50, LVQ60

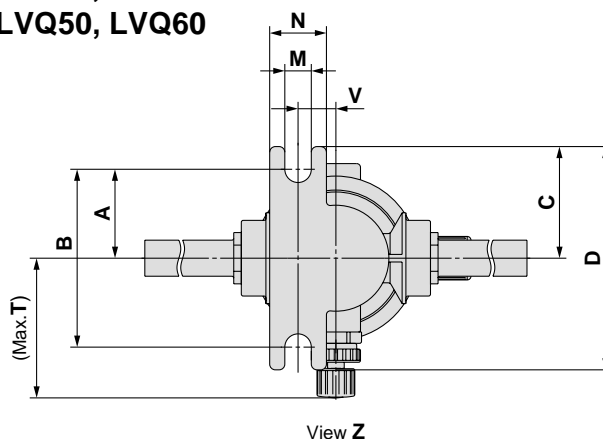

Dimensions

Model	A	B	C	D	M	N	S	T	U	V
LVQ20-T□-3	25.5	46	31.5	58	7	15	83	34.3	10.6	7
LVQ30-T□-3	25.5	51	31.5	63	7	15	113.5	36.9	16.5	10
LVQ40-T□-3	25.5	51	31.5	63	7	15	119	37.9	22	10
LVQ50-T□-3	38	76	44	88	7	20	171.5	64	25	17
LVQ60-T□-3	38	76	44	88	7	20	182.5	66	32	17

With indicator, High back pressure spec. with indicator
N.C. valve

Dimensions (mm)

Model	S
LVQ20-T□-4	70.5
LVQ30-T□-4	88.5
LVQ40-T□-4	94
LVQ50-T□-4	134.5
LVQ60-T□-4	144

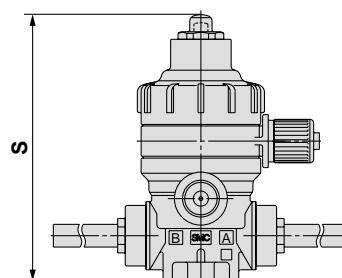

Series LVQ-T

Dimensions

Basic type N.O. valve

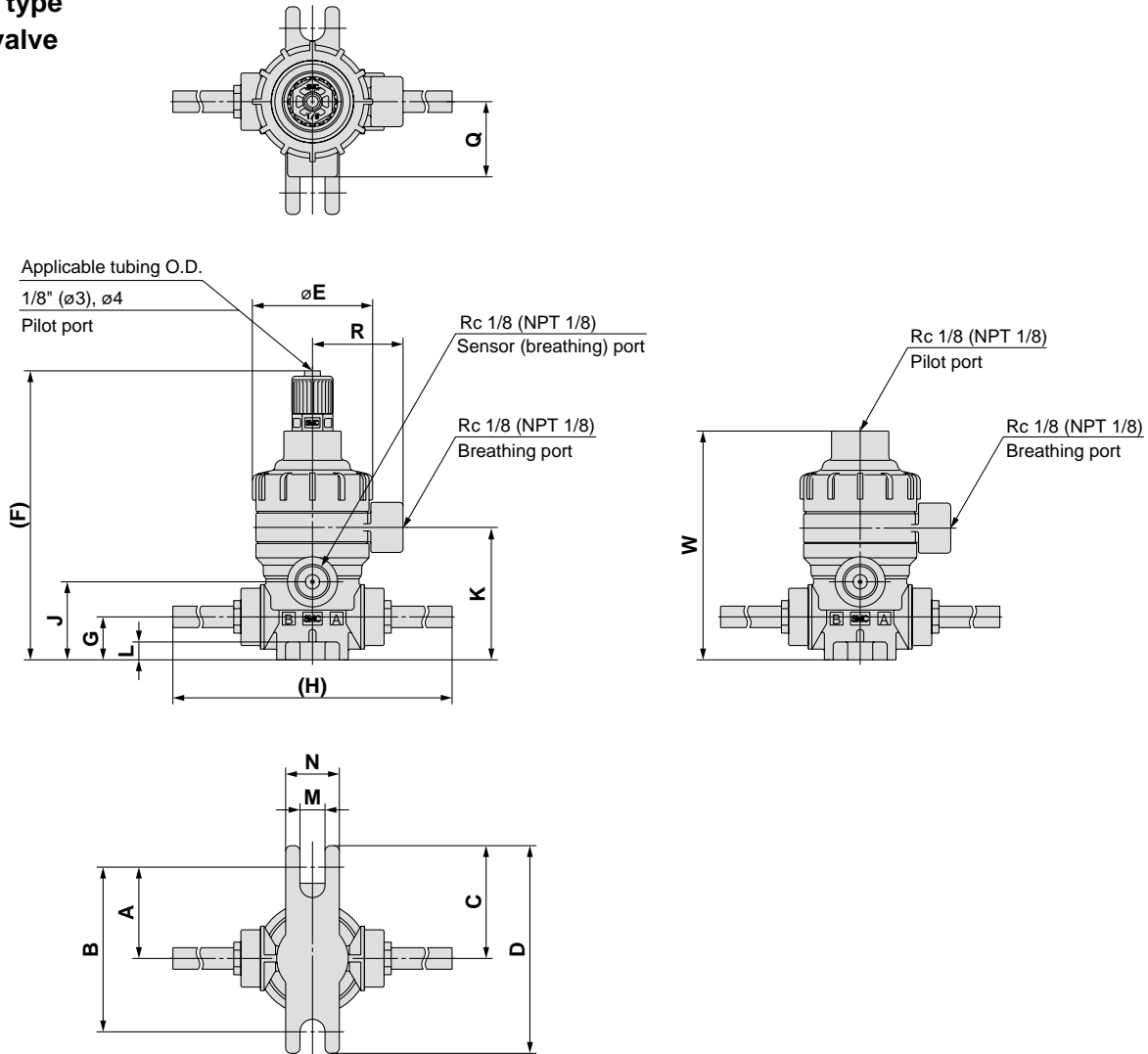

Double acting valve

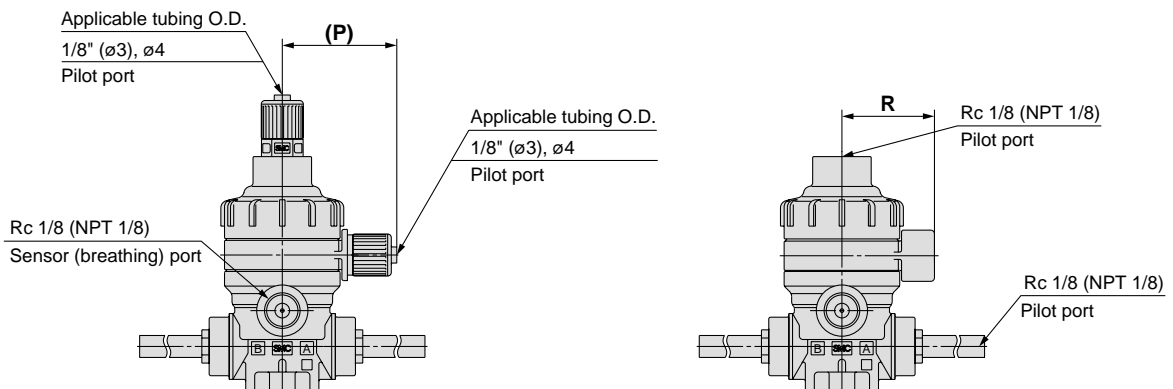

LVQ□₂-T□ Dimensions (N.O. valve, double acting valve)

(mm)

Model	A	B	C	D	E	F	G	H	J	K	L	M	N	P	Q	R	W
LVQ2 ₂ -T□	25.5	46	31.5	58	33.6	81	12	111.5	21.8	37	5	7	15	31.3	21	25.3	64
LVQ3 ₂ -T□	28.5	57	34.5	69	45.4	99	16.5	136	32	50	6	7	20	37.2	25	31.2	82
LVQ4 ₂ -T□	28.5	57	34.5	69	45.4	104	22	137	37.5	55.5	6	7	20	37.2	25	31.2	87.5
LVQ5 ₂ -T□	42	84	48	96	75	144.5	25	180	50.2	78.2	10	7	20	50.8	38.5	45	128
LVQ6 ₂ -T□	42	84	48	96	75	154.5	32	189	60	88	10	7	20	50.8	38.5	45	137.5

With bypass
Double acting valve

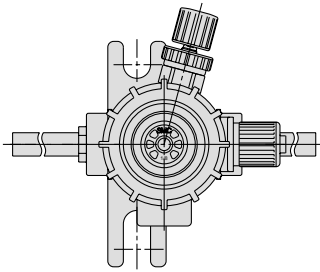

LVQ2¹₂

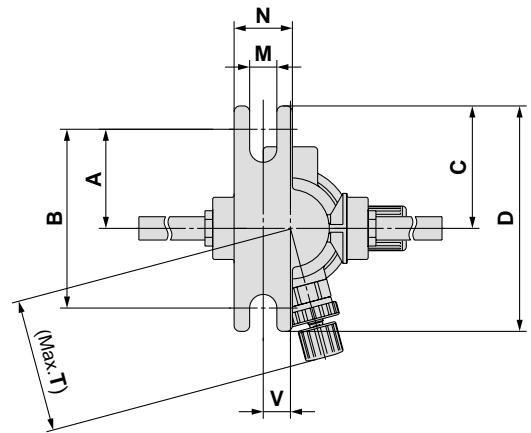

LVQ3¹₂, LVQ4¹₂
LVQ5¹₂, LVQ6¹₂

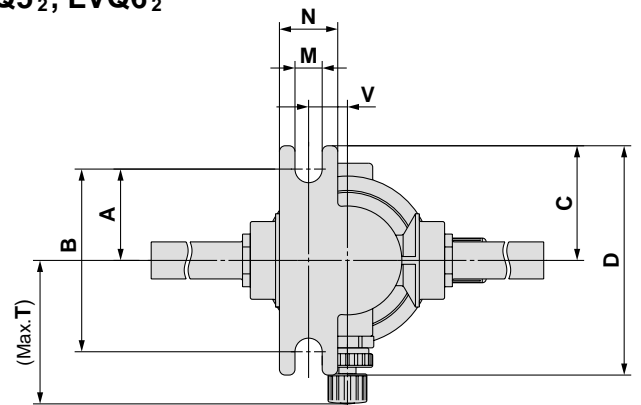
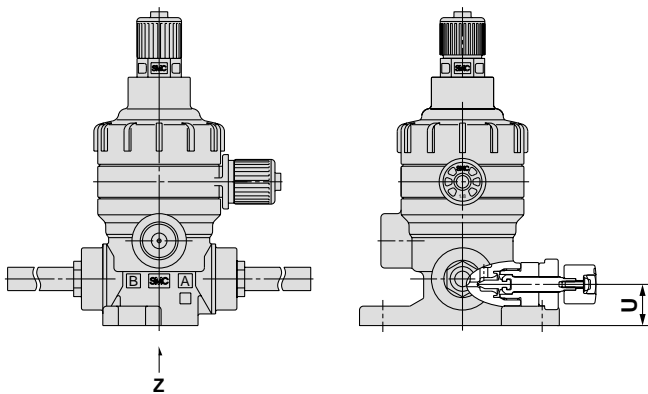

View Z

- LVC
- LVA
- LVH
- LVD
- LVQ
- LQ1
- LVN
- TL/TIL
- LQ3

Dimensions (mm)

Model	A	B	C	D	M	N	T	U	V
LVQ2 ¹ ₂ -T□-2	25.5	46	31.5	58	7	15	34.3	10.6	7
LVQ3 ¹ ₂ -T□-2	25.5	51	31.5	63	7	15	36.9	16.5	10
LVQ4 ¹ ₂ -T□-2	25.5	51	31.5	63	7	15	37.9	22	10
LVQ5 ¹ ₂ -T□-2	38	76	44	88	7	20	64	25	17
LVQ6 ¹ ₂ -T□-2	38	76	44	88	7	20	64	32	17

Manual Type Tube Extension Fitting Type Series **LVQH-T**

How to Order

LVQH **2** 0 - T **07** - **1** -

Body class

Symbol	Body class	Orifice dia.
2	2	ø4
3	3	ø8
4	4	ø10
5	5	ø16
6	6	ø22

Option

Symbol	Note
Nil	Standard
K	Buffer material FFKM
N	For ammonium hydroxide



Note) Options cannot be combined with each other.

Tube Extension Fitting

Applicable tubing size

Symbol	Connecting tubing O.D.	Body class				
		2	3	4	5	6
Metric sizes						
06	ø6	○				
10	ø10		○			
12	ø12			○		
19	ø19				○	
25	ø25					○
Inch sizes						
07	1/4	○				
11	3/8		○			
13	1/2			○		
19	3/4				○	
25	1					○

Handle operation

1	90 Degree turn type
4	Multi-turn type (with indicator)

Breathing port thread type

Nil	Threaded	NPT 1/8
R	Threaded	Rc 1/8

Variations

Type	Symbol	Model	Connection fitting size				
			Orifice diameter				
			LVQH20-T	LVQH30-T	LVQH40-T	LVQH50-T	LVQH60-T
			ø4	ø8	ø10	ø16	ø22
			6	10	12	19	25
			1/4	3/8	1/2	3/4	1
90 Degree turn type			○	○	○	○	○
Multi-turn type			○	○	○	○	○

Standard Specifications



Model		LVQH20	LVQH30	LVQH40	LVQH50	LVQH60
Tubing O.D.	Metric size	6	10	12	19	25
	Inch size	1/4	3/8	1/2	3/4	1
Orifice diameter		ø4	ø8	ø10	ø16	ø22
Flow characteristics	$Av \times 10^{-6}m^2$	8.4	31.2	45.6	120	192 (228) ^{Note)}
	Cv	0.35	1.3	1.9	5	8 (9.5) ^{Note)}
Withstand pressure (MPa)		1				
Operating pressure <A→B flow>		-98 kPa to 0.5 MPa			-98 kPa to 0.4 MPa	
Back pressure (MPa)		0.3 or less			0.2 or less	
Valve leakage (cm ³ /min)		0 (With water pressure)				
Fluid temperature (°C)		0 to 100				
Ambient temperature (°C)		0 to 60				
Mass (kg)	LVQH□0-1	0.12	0.25	0.28	1.04	1.05
	LVQH□0-4	0.11	0.18	0.19	0.62	0.73

Note) () is high flow specification.

Construction

90 Degree turn type

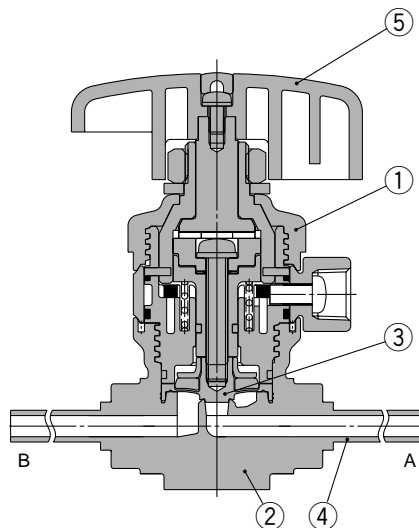

Multi-turn type (with indicator)

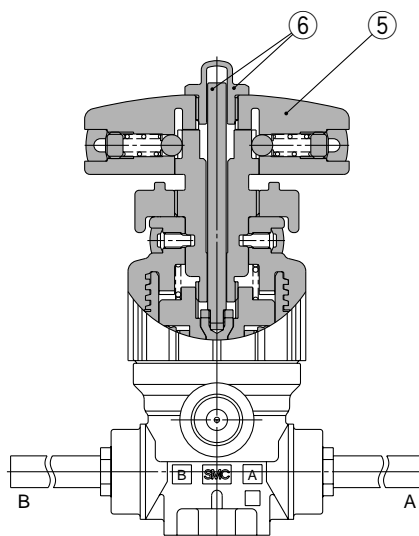

Parts list

No.	Description	Material
1	Actuator section	PVDF
2	Body	PFA
3	Diaphragm	PTFE
4	Insert bushing	PFA
5	Handle section	PVDF
6	Indicator, cover	PP

LVC
LVA
LVH
LVD
LVQ
LQ1
LVN
TL/TIL
LQ3

Series LVQH-T

Dimensions

90 Degree turn type

Dimensions

(mm)

Model	A	B	C	D	F	G	H
LVQH20-T□-1	25.5	46	31.5	58	79	12	111.5
LVQH30-T□-1	28.5	57	34.5	69	103	16.5	136
LVQH40-T□-1	28.5	57	34.5	69	108	22	137
LVQH50-T□-1	42	84	48	96	165	25	180
LVQH60-T□-1	42	84	48	96	175	32	189

Model	J	K	L	M	N	Q	Y
LVQH20-T□-1	21.8	37	5	7	15	21	55
LVQH30-T□-1	32	50	6	7	20	25	80
LVQH40-T□-1	37.5	55.5	6	7	20	25	80
LVQH50-T□-1	50.2	78.2	10	7	20	38.5	110
LVQH60-T□-1	60	88	10	7	20	38.5	110

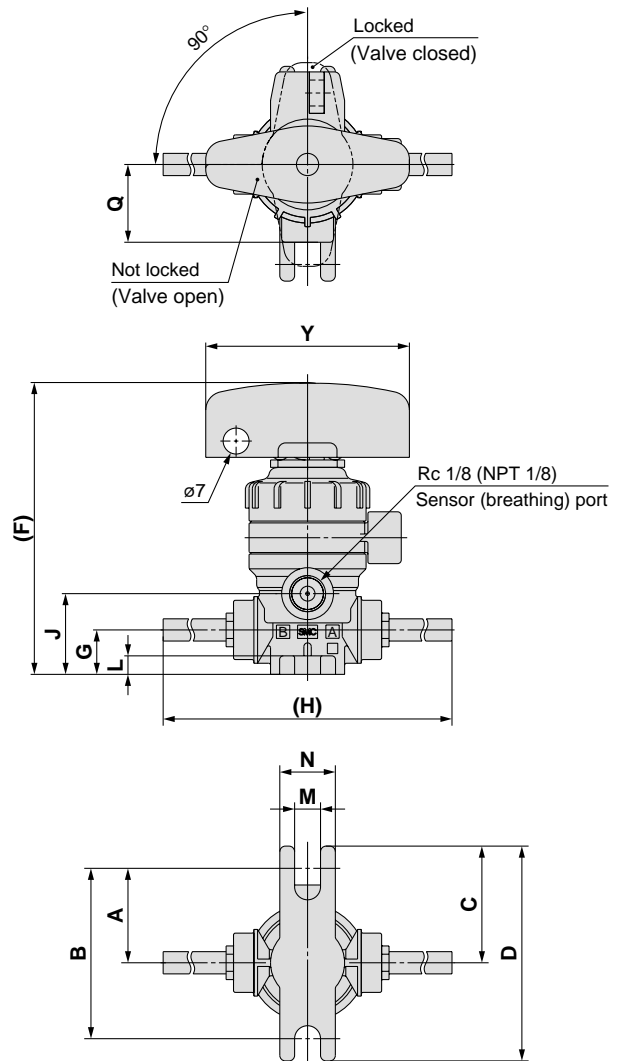

Multi-turn type (with indicator)

Dimensions

(mm)

Model	S	Y
LVQH20-T□-4	89.6	50
LVQH30-T□-4	107.2	50
LVQH40-T□-4	112.7	50
LVQH50-T□-4	165	71
LVQH60-T□-4	174.5	71

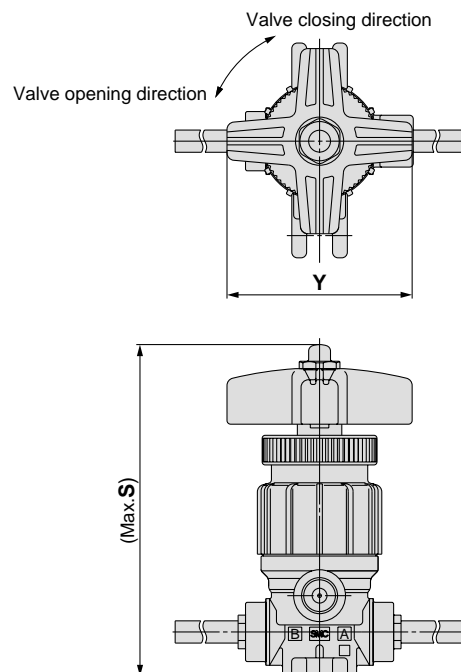

Air Operated Type for Back Pressure 0.5 MPa Integral Fitting Type (Hyper Fittings)

Series LVQ□□H

How to Order

LVQ **2** **0** H - **S** **07** □ □ - □ **Option**

Body class

Symbol	Body class	Orifice dia.
2	2	ø4
3	3	ø8
4	4	ø10
5	5	ø16
6	6	ø22

Valve type

0	N.C.
1	N.O.
2	Double acting

Note) Refer to variations in the table below for valve type combinations.

Fitting type

Symbol	Fittings	Body class
V	LQ1	2, 3, 4, 5, 6
S	LQ2	2, 3, 4, 5

Applicable tubing size

Symbol	Connecting tubing O.D.	Body class					
		2	3	4	5	6	
Metric sizes							
03	ø3	●					
04	ø4	●					
06	ø6	○	●				
08	ø8		●				
10	ø10		○	●			
12	ø12			○	●		
19	ø19				○	●	
25	ø25					○	●
Inch sizes							
03	1/8	●					
05	3/16	●					
07	1/4	○	●				
11	3/8		○	●			
13	1/2			○	●		
19	3/4				○	●	
25	1					○	●

○ Basic size ● With reducer

Option	Description
Nil	None
1	With flow rate adjustment
2	With bypass
3	With flow rate adjustment & bypass
4	With indicator
24	With indicator & bypass

Note) Refer to variations in the table below for valve type and option combinations. Options can not be combined with each other.

Pilot port thread type

Nil	LQ1 integral fitting	Connection tubing O.D. 1/8" (ø3)
M	LQ1 integral fitting	Connection tubing O.D. ø4
R	Threaded	Rc 1/8
N	Threaded	NPT 1/8

Port B (OUT) different dia. size

Symbol	Application
Nil	Ports A & B same size
	Refer to the applicable tubing table to the left. Different diameter tubings can be selected within the same body class.

Variations

Type	Symbol	Model	Orifice diameter				
			Tubing outside dia.				
			LVQ20H	LVQ30H	LVQ40H	LVQ50H	LVQ60H
			ø4	ø8	ø10	ø16	ø22
			6	10	12	19	25
			1/4	3/8	1/2	3/4	1
			Valve type				
Basic type							
		N.C.	○	○	○	○	○
		N.O.	○	○	○	○	○
		Double acting	○	○	○	○	○
With flow rate adjustment							
		N.C.	○	○	○	○	○
		Double acting	○	○	○	○	○
With bypass							
		N.C.	○	○	○	○	○
		Double acting	○	○	○	○	○
		Double acting	○	○	○	○	○
With flow rate adjustment & bypass							
		N.C.	○	○	○	○	○
		Double acting	○	○	○	○	○
With indicator							
		N.C.	○	○	○	○	○
		Double acting	○	○	○	○	○
With indicator & bypass							
		N.C.	○	○	○	○	○
		Double acting	○	○	○	○	○

Air Operated Type for Back Pressure 0.5 MPa Flare Integral Fitting Type (Hyper Fittings)

Series LVQ□□H-Z

How to Order

LVQ 2 0 H-Z 07 □ - □

Body class

Symbol	Body class	Orifice dia.
2	2	ø4
3	3	ø8
4	4	ø10
5	5	ø16
6	6	ø22

Valve type

0	N.C.
1	N.O.
2	Double acting



Note) Refer to variations in the table below for valve type combinations.

LQ3
integral
fittings

Option

Nil	None
1	With flow rate adjustment
2	With bypass
3	With flow rate adjustment & bypass
4	With indicator
24	With indicator & bypass



Note) Refer to variations in the table below for valve type and option combinations. Options can not be combined with each other.

Applicable tubing size

Symbol	Connecting tubing O.D.	Body class					
		2	3	4	5	6	
Metric sizes							
03	ø3		○				
04	ø4		○				
06	ø6		○				
08	ø8			○			
10	ø10			○			
12	ø12				○		
19	ø19					○	
25	ø25						○
Inch sizes							
07	1/4		○				
11	3/8			○			
13	1/2				○		
19	3/4					○	
25	1						○

Pilot port thread type

Nil	LQ3 integral fitting	Connection tubing O.D. 1/8" (ø3)
M	LQ3 integral fitting	Connection tubing O.D. ø4
R	Threaded	Rc 1/8
N	Threaded	NPT 1/8

Variations

Type	Symbol	Valve type	Model						
			Orifice diameter		LVQ20H	LVQ30H	LVQ40H	LVQ50H	LVQ60H
			Tubing outside dia.	Millimeter	ø4	ø8	ø10	ø16	ø22
		Inch	1/4	3/8	1/2	3/4	1		
Basic type 		N.C.	○	○	○	○	○		
		N.O.	○	○	○	○	○		
		Double acting	○	○	○	○	○		
With flow rate adjustment 		N.C.	○	○	○	○	○		
With bypass 		N.C.	○	○	○	○	○		
		Double acting	○	○	○	○	○		
With flow rate adjustment & bypass 		N.C.	○	○	○	○	○		
With indicator 		N.C.	○	○	○	○	○		
With indicator & bypass 		N.C.	○	○	○	○	○		

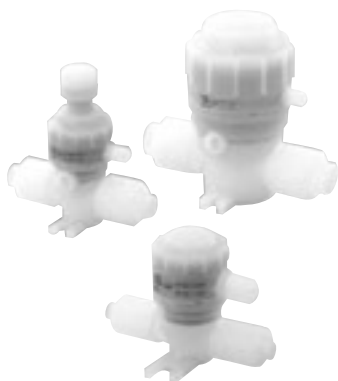

Standard Specifications

Model		LVQ20H	LVQ30H	LVQ40H	LVQ50H	LVQ60H
Tubing O.D.	Metric size	6	10	12	19	25
	Inch size	1/4	3/8	1/2	3/4	1
Orifice diameter		ø4	ø8	ø10	ø16	ø22
Flow characteristics	Av x 10 ⁻⁶ m ²	8.4	31.2	45.6	120	192 (228) ^{Note)}
	Cv	0.35	1.3	1.9	5	8 (9.5) ^{Note)}
Withstand pressure (MPa)		1				
Operating pressure <A→B flow>		-98 kPa to 0.5 MPa				
Back pressure (MPa)		0.5 or less				
Valve leakage (cm ³ /min)		0 (With water pressure)				
Pilot air pressure (MPa)		0.5 to 0.8				
Pilot port size		1/8" (ø3), ø4, Rc 1/8, NPT 1/8				
Fluid temperature (°C)		0 to 100				
Ambient temperature (°C)		0 to 60				
Mass (kg)		0.08	0.17	0.22	0.70	0.81

Note) () is high flow specification.

Dimensions

Dimensions will be the same as the standard specifications.

Different Diameter Tubing Applicable with Reducer (For LVQ□□H-V_s)

Different diameter tubing can be selected (within a body class) by using a nut and insert bushing (reducer).

● With reducer

Body class	Tubing O.D.													
	Metric sizes							Inch sizes						
	4	6	8	10	12	19	25	1/8	3/16	1/4	3/8	1/2	3/4	1
2	●	○	—	—	—	—	—	●	●	○	—	—	—	—
3	—	●	●	○	—	—	—	—	—	●	○	—	—	—
4	—	—	—	●	○	—	—	—	—	—	●	○	—	—
5	—	—	—	—	●	○	—	—	—	—	—	●	○	—
6	—	—	—	—	—	●	○	—	—	—	—	—	●	○

Note) Refer to page 544 for information on changing tubing sizes.

! Specific Product Precautions

Be sure to read before handling. Refer to front matters 42 and 43 for Safety Instructions, and pages 585 and 586 for High Purity Chemical Valve Non-Metallic Exterior Precautions.

Piping

! Caution

1. Connect tubing with special tools.

Refer to the pamphlet "High-Purity Fluoropolymer Fittings HYPER FITTING®/Series LQ1, 2 Work Procedure Instructions" (M-E05-1) or "High Purity Fluoropolymer Fittings Hyper Fitting/Flare Type Series LQ3 Fitting Procedure" (M-E06-4A) for connecting tubing and special tools. (Downloadable from our web site.)

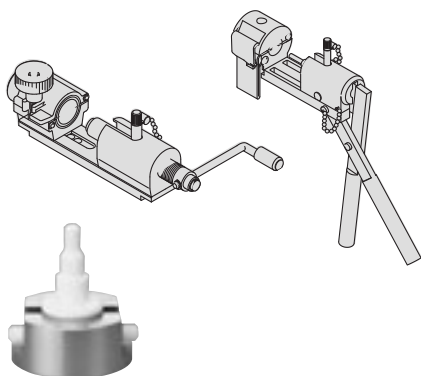

2. Tighten the nut to the end surface of the body. As a guide, refer to the proper tightening torques shown below.

Tightening torque for piping

Body class	Torque (N·m)		
	LQ1	LQ2	LQ3
2	0.3 to 0.4	1.5 to 2.0	1.6 to 1.8
3	0.8 to 1.0	3.0 to 3.5	3.2 to 3.5
4	1.0 to 1.2	7.5 to 9.0	5.0 to 5.3
5	2.5 to 3.0	11.0 to 13.0	10.0 to 10.5
6	5.5 to 6.0		22.5 to 23.0

LVC

LVA

LVH

LVD

LVQ

LQ1

LVN

TL/TIL

LQ3



Applicable Fluids

Material and fluid compatibility check list for air operated chemical valves

Chemical	Compatibility
Acetone	<input type="radio"/> Note 1, 2)
Ammonium hydroxide	<input type="radio"/> Note 2)
Isobutyl alcohol	<input type="radio"/> Note 1, 2)
Isopropyl alcohol	<input type="radio"/> Note 1, 2)
Hydrochloric acid	<input type="radio"/>
Ozone (dry)	<input type="radio"/>
Hydrogen peroxide Concentration 5% or less, 50°C or less	<input type="radio"/>
Ethyl acetate	<input type="radio"/> Note 1, 2)
Butyl acetate	<input type="radio"/> Note 1, 2)
Nitric acid (except fuming nitric acid) Concentration 10% or less	<input type="radio"/> Note 2)
DI water	<input type="radio"/>
Sodium hydroxide Concentration 50% or less	<input type="radio"/>
Nitrogen gas	<input type="radio"/>
Super pure water	<input type="radio"/>
Toluene	<input type="radio"/> Note 1, 2)
Hydrofluoric acid	<input type="radio"/> Note 2)
Sulfuric acid (except fuming sulfuric acid)	<input type="radio"/> Note 2)
Phosphoric acid Concentration 80% or less	<input type="radio"/>

Table symbols : Can be used
 : Can be used in certain conditions
× : Cannot be used



The material and fluid compatibility check list provides reference values as a guide only.

Note 1) Since static electricity may be generated, implement suitable countermeasures.

Note 2) Use caution as permeation may occur. The permeated fluid may effect the parts of other materials.

- Compatibility is indicated for fluid temperatures of 100°C or less.
- The material and fluid compatibility check list provides reference values as a guide only, therefore we do not guarantee the application to our product.
- The data above is based on the information presented by the material manufacturers.
- SMC is not responsible for its accuracy and any damage happened because of this data.



Series LVQ

High Purity Chemical Valve Non-Metallic Exterior Specific Product Precautions 1

Be sure to read before handling.

Design & Selection

⚠ Warning

1. Confirm the specifications.

Give careful consideration to operating conditions such as the application, fluid and environment, and use within the operating ranges specified in this catalog.

2. Fluids

Operate after confirming the compatibility of the product's component materials with fluids, using the check list on features page 584. Contact SMC regarding fluids other than those in the check list.

Operate within the indicated fluid temperature range.

3. Maintenance space

Ensure the necessary space for maintenance and inspections.

4. Fluid pressure range

Keep the supplied fluid pressure within the operating pressure range shown in the catalog.

5. Ambient environment

Operate within the ambient operating temperature range. After confirming the compatibility of the product's component materials with the ambient environment, operate so that fluid does not adhere to the product's exterior surfaces.

6. Liquid seals

When circulating fluid

Provide a relief valve in the system so that fluid does not get into the liquid seal circuit.

7. Countermeasures for static electricity

Since static electricity may be generated depending on the fluid being used, implement suitable countermeasures.

Mounting

⚠ Warning

1. If air leakage increases or equipment does not operate properly, stop operation.

After mounting, perform suitable function and leak tests to confirm that the mounting is correct.

2. Instruction manual

Mount and operate the product after reading the manual carefully and understanding its contents. Also keep the manual where it can be referred to as necessary.

Piping

⚠ Caution

1. Preparation before piping

Before piping is connected, it should be thoroughly blown out with air (flushing) or washed to remove chips, cutting oil and other debris from inside the pipe.

Install piping so that it does not apply pulling, pressing, bending or other forces on the valve body.

2. Use the tightening torques shown below for the threaded pilot port.

Operating port tightening torque

Operating port	Torque (N·m)
Rc, NPT 1/8	0.8 to 1.0

3. Use of metal fittings

In the case of threaded pilot port, do not pipe the metallic fittings which can cause damage to the thread part.

4. Refer to the pamphlet "High-Purity Fluoropolymer Fittings HYPER FITTING®/Series LQ1, 2 Work Procedure Instructions" (M-E05-1) or "High Purity Fluoro polymer Fittings Hyper Fitting/Flare Type Series LQ3 Fitting Procedure" (M-E06-4) for connecting tubing and special tools. (Downloadable from our web site.)

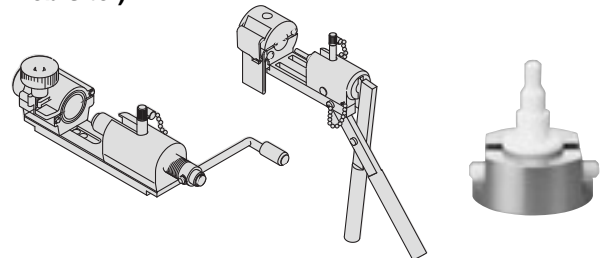

Operating Air Supply

⚠ Warning

1. Use clean air.

Do not use compressed air which includes chemicals, synthetic oils containing organic solvents, salt, or corrosive gases, etc., as this may cause damage or malfunction.

LVC

LVA

LVH

LVD

LVQ

LQ1

LVN

TL/TIL

LQ3



Series LVQ

High Purity Chemical Valve Non-Metallic Exterior Specific Product Precautions 2

Be sure to read before handling.

Operating Environment

Warning

1. Do not use in a location having an explosive atmosphere.
2. Do not operate in locations where vibration or impact occurs.
3. Do not use in locations where radiated heat will be received from nearby heat sources.

Maintenance

Warning

1. Maintenance should be performed in accordance with the procedures in the instruction manual.
Incorrect handling can cause damage or malfunction of machinery and equipment, etc.
2. Before removing equipment or compressed air supply/exhaust devices, shut off the air and power supplies, and exhaust compressed air from the system.
Further, when restarting equipment after remounting or replacement, first confirm safety and then check the equipment for normal operation.
3. Perform work after removing residual chemicals and carefully replacing them with DI water or air, etc.
4. Do not disassemble the product. Products which have been disassembled cannot be guaranteed.
If disassembly is necessary, contact SMC.
5. In order to obtain optimum performance from valves, perform periodic inspections to confirm that there are no leaks from valves or fittings, etc.

Caution

1. Removal of drainage
Flush drainage from filters regularly.

Precautions on Usage

Warning

1. Operate within the ranges of the maximum operating pressure and back pressure.

Caution

1. Please note that when the product is shipped from the factory, gases such as N₂ and air may leak from the valve at a rate of 1cm³/min (when pressurized).
2. When operated at a very low flow rate, the series LVQ with flow rate adjustment may vibrate, etc. depending on the operating conditions. Therefore, operate it after careful examination of the flow rate, pressure and piping conditions.
3. In the series LVQ, water hammering may occur depending on the fluid pressure conditions. In most cases, improvement is possible by adjusting the pilot pressure with a speed controller, etc., but the flow rate, pressure and piping conditions should be reviewed.
4. To adjust the flow rate for the series LVQ with flow rate adjustment, open gradually starting from the fully closed condition.
Opening is accomplished by turning the adjustment knob counter clockwise.
Additionally, do not apply any unreasonable force to the adjustment knob when nearing a fully opened or closed state. This may result in deformation of the orifice sheet surface or damage to the threaded part of the adjustment knob.
It is in the fully closed condition when the product is shipped from the factory.
5. After a long period of nonuse, perform a test run before beginning regular operation.
6. Since the LVQ is packaged in a clean room use sufficient care in handling when opened.