

Low Profile Slide Table

Series MXF

ø8, ø12, ø16, ø20

Low-profile and compact type, air slide table with the construction of guide and cylinder aligned in parallel.

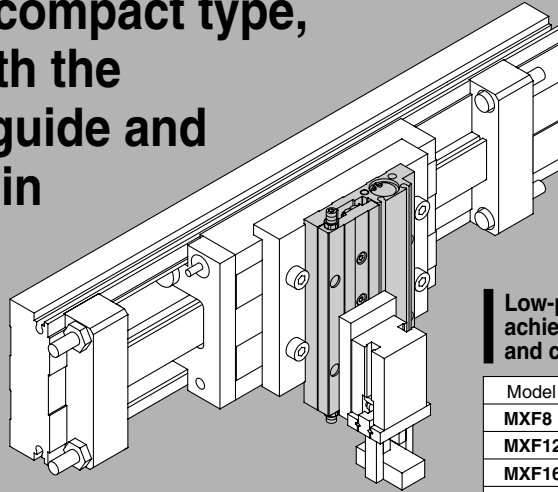

Low-profile and compactness have been achieved with the construction of guide and cylinder aligned in parallel.

Model	Height x Width (mm)	Height comparison to MXS
MXF8	16 x 58	67%
MXF12	18.5 x 68	59%
MXF16	21 x 80	53%
MXF20	27 x 92	54%

Neat appearance

Protecting stopper section with cover realizes neat appearance.

Standard stroke adjustment

Stroke can be adjusted at each stroke end within 5 mm each end and 10 mm is total.

Body mounting (Body tapped)

Auto switch is mountable

Auto switch is recessed in the groove to save space.

Slim body

Low-profile has been achieved with the construction of guide and cylinder aligned in parallel.

Reproducibility for mounting and dismantling

Positioning pin holes on table top allows precise and easy mounting to change workpiece.

High rigidity

Cross roller guide allows smooth operation without vibration.

Optional porting

Lateral and axial piping from 2 directions is possible.

Stronger thread for mounting work

Insert thread for mounting work.

Reproducibility for mounting and dismantling

Pin holes for positioning on bottom of slide allows precise and accurate mounting of actuator.

Body mounting (Body tapped)

Mounting can be done from 2 directions top side (through-hole) and bottom side (body tapped).

1. Body tapped



2. Body through-hole

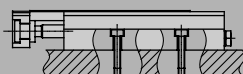

Series Variations

Model	Bore size (mm)	Stroke (mm)						Auto switch	
		10	20	30	50	75	100		
MXF8	8	•	•	•	•	•	•	Reed auto switch D-A9□, D-A9□V	D-□
MXF12	12		•	•	•	•	•	Solid state auto switch D-M9□, D-M9□V	-X□
MXF16	16			•	•	•	•	2-color indication solid state auto switch D-M9□W, D-M9□VW	Individual -X□
MXF20	20				•	•	•		

Series MXF

Model Selection

Model Selection Step	Formula/Data	Selection Example				
1 Operating Conditions Enumerate the operating conditions considering the mounting position and workpiece configuration.	<ul style="list-style-type: none"> Model to be used Type of cushion Workpiece mounting position Mounting orientation Average speed V_a (mm/s) Load mass W (kg): Fig. (1) Overhang L_n (mm): Fig. (2) 	 <p>Cylinder: MXF20-50 Cushion: Rubber bumper Workpiece table mounting Mounting: Horizontal wall mounting Average speed: $V_a = 300$ [mm/s] Allowable load: $W = 0.5$ [kg] $L_1 = 10$ mm $L_2 = 30$ mm $L_3 = 30$ mm</p>				
2 Kinetic Energy Find the kinetic energy E (J) of the load. Find the allowable kinetic energy E_a (J). Confirm that the kinetic energy of the load does not exceed the allowable kinetic energy.	$E = \frac{1}{2} \cdot W \left(\frac{V}{1000} \right)^2$ <p>Collision speed $V = 1.4 \cdot V_a$ <small>(Correction factor (Reference values))</small> $E_a = K \cdot E_{max}$ Workpiece mounting coefficient K: Fig. (3) Max. allowable kinetic energy E_{max}: Table (1) Kinetic energy (E) \leq Allowable kinetic energy (E_a)</p>	$E = \frac{1}{2} \cdot 0.5 \left(\frac{420}{1000} \right)^2 = 0.044$ $V = 1.4 \times 300 = 420$ $E_a = 1 \cdot 0.16 = 0.16$ Can be used based on $E = 0.044 \leq E_a = 0.16$				
3 Load Factor						
3-1 Load factor of load mass Find the allowable load mass W_a (kg). Note) No need to consider this load factor in the case of using perpendicularly in a vertical position. (Define $\alpha_1 = 0$.) Find the load factor of the load mass α_1 .	$W_a = K \cdot \beta \cdot W_{max}$ <p>Workpiece mounting coefficient K: Fig. (3) Allowable load mass coefficient β: Graph (1) Max. allowable load mass W_{max}: Table (2) $\alpha_1 = W/W_a$</p>	$W_a = 1 \times 1 \times 4 = 4$ $K = 1$ $\beta = 1$ $W_{max} = 4$ $\alpha_1 = 0.5/4 = 0.125$				
3-2 Load factor of the static moment Find the static moment M (N·m). Find the allowable static moment M_a (N·m). Find the load factor α_2 of the static moment.	$M = W \times 9.8 (L_n + A_n)/1000$ <p>Moment center position distance compensation amount A_n: Table (3) $M_a = K \cdot \gamma \cdot M_{max}$ Workpiece mounting coefficient K: Fig. (3) Allowable moment coefficient γ: Graph (2) Maximum allowable moment M_{max}: Table (4) $\alpha_2 = M/M_a$</p>	<table border="1"> <thead> <tr> <th>Yawing</th> <th>Rolling</th> </tr> </thead> <tbody> <tr> <td> Examine M_y. $M_y = 0.5 \times 9.8 (10 + 11)/1000 = 0.11$ $A_3 = 11$ $M_{ay} = 1 \times 1 \times 9.14 = 9.14$ $M_{ymax} = 9.14$ $K = 1$ $\gamma = 1$ $\alpha_2 = 0.11/9.14 = 0.012$ </td> <td> Examine M_r. $M_r = 0.5 \times 9.8 (30 + 17)/1000 = 0.23$ $A_6 = 17$ $M_{ar} = 9.14$ (Same as M_{ay}) $\alpha_2' = 0.23/9.14 = 0.025$ </td> </tr> </tbody> </table>	Yawing	Rolling	Examine M_y. $M_y = 0.5 \times 9.8 (10 + 11)/1000 = 0.11$ $A_3 = 11$ $M_{ay} = 1 \times 1 \times 9.14 = 9.14$ $M_{ymax} = 9.14$ $K = 1$ $\gamma = 1$ $\alpha_2 = 0.11/9.14 = 0.012$	Examine M_r. $M_r = 0.5 \times 9.8 (30 + 17)/1000 = 0.23$ $A_6 = 17$ $M_{ar} = 9.14$ (Same as M_{ay}) $\alpha_2' = 0.23/9.14 = 0.025$
Yawing	Rolling					
Examine M_y. $M_y = 0.5 \times 9.8 (10 + 11)/1000 = 0.11$ $A_3 = 11$ $M_{ay} = 1 \times 1 \times 9.14 = 9.14$ $M_{ymax} = 9.14$ $K = 1$ $\gamma = 1$ $\alpha_2 = 0.11/9.14 = 0.012$	Examine M_r. $M_r = 0.5 \times 9.8 (30 + 17)/1000 = 0.23$ $A_6 = 17$ $M_{ar} = 9.14$ (Same as M_{ay}) $\alpha_2' = 0.23/9.14 = 0.025$					
3-3 Load factor of dynamic moment Find the dynamic moment M_e (N·m). Find the allowable dynamic moment M_{ea} (N·m). Find the load factor α_3 of the dynamic moment.	$M_e = 1/3 \cdot W_e \times 9.8 \frac{(L_n + A_n)}{1000}$ <p>Collision equivalent to impact $W_e = \delta \cdot W \cdot V$ δ: Bumper coefficient With urethane bumper (Standard) = 4/100 Corrected value for moment center position distance A_n: Table (3) $M_{ea} = K \cdot \gamma \cdot M_{max}$ Workpiece mounting coefficient K: Fig. (3) Allowable moment coefficient γ: Graph (2) Max. allowable moment M_{max}: Graph (4) $\alpha_3 = M_e/M_{ea}$</p>	<table border="1"> <thead> <tr> <th>Pitching</th> <th>Yawing</th> </tr> </thead> <tbody> <tr> <td> Examine M_{ep}. $M_{ep} = 1/3 \times 8.4 \times 9.8 \times \frac{(30 + 17)}{1000} = 1.3$ $W_e = 4/100 \times 0.5 \times 420 = 8.4$ $A_2 = 17$ $M_{eap} = 1 \times 0.7 \times 9.14 = 6.40$ $K = 1$ $\gamma = 0.7$ $M_{pmax} = 9.14$ $\alpha_3 = 1.3/6.40 = 0.20$ </td> <td> Examine M_{ey}. $M_{ey} = 1/3 \times 8.4 \times 9.8 \times \frac{(30 + 34)}{1000} = 1.8$ $W_e = 8.4$ $A_4 = 34$ $M_{eay} = 6.40$ (Same value as M_{eap}) $\alpha_3 = 1.8/6.4 = 0.28$ </td> </tr> </tbody> </table>	Pitching	Yawing	Examine M_{ep}. $M_{ep} = 1/3 \times 8.4 \times 9.8 \times \frac{(30 + 17)}{1000} = 1.3$ $W_e = 4/100 \times 0.5 \times 420 = 8.4$ $A_2 = 17$ $M_{eap} = 1 \times 0.7 \times 9.14 = 6.40$ $K = 1$ $\gamma = 0.7$ $M_{pmax} = 9.14$ $\alpha_3 = 1.3/6.40 = 0.20$	Examine M_{ey}. $M_{ey} = 1/3 \times 8.4 \times 9.8 \times \frac{(30 + 34)}{1000} = 1.8$ $W_e = 8.4$ $A_4 = 34$ $M_{eay} = 6.40$ (Same value as M_{eap}) $\alpha_3 = 1.8/6.4 = 0.28$
Pitching	Yawing					
Examine M_{ep}. $M_{ep} = 1/3 \times 8.4 \times 9.8 \times \frac{(30 + 17)}{1000} = 1.3$ $W_e = 4/100 \times 0.5 \times 420 = 8.4$ $A_2 = 17$ $M_{eap} = 1 \times 0.7 \times 9.14 = 6.40$ $K = 1$ $\gamma = 0.7$ $M_{pmax} = 9.14$ $\alpha_3 = 1.3/6.40 = 0.20$	Examine M_{ey}. $M_{ey} = 1/3 \times 8.4 \times 9.8 \times \frac{(30 + 34)}{1000} = 1.8$ $W_e = 8.4$ $A_4 = 34$ $M_{eay} = 6.40$ (Same value as M_{eap}) $\alpha_3 = 1.8/6.4 = 0.28$					
3-4 Sum of the load factors Use is possible if the sum of the load factors does not exceed 1.	$\sum \alpha_n = \alpha_1 + \alpha_2 + \alpha_3 \leq 1$	$\sum \alpha_n = \alpha_1 + \alpha_2 + \alpha_2' + \alpha_3 + \alpha_3'$ $= 0.125 + 0.012 + 0.025 + 0.20 + 0.28 = 0.642 \leq 1$ And it is possible to use.				

Fig. (1) Load mass: W (kg)



Note) No need to consider this load factor in the case of using perpendicularly in a vertical position.

Fig. (3) Workpiece Mounting Coefficient: K

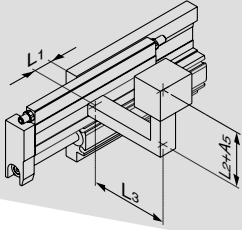
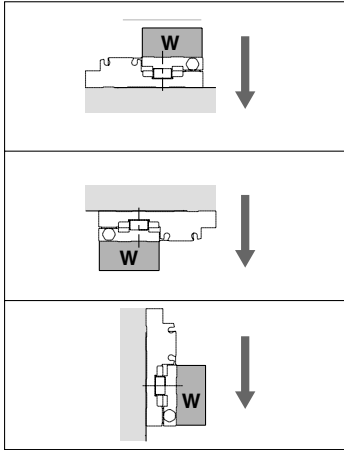
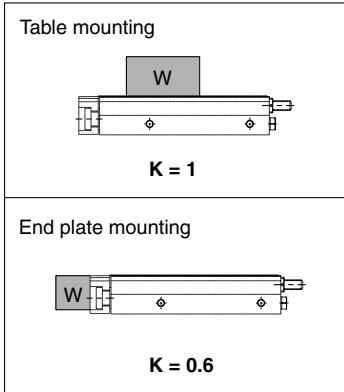
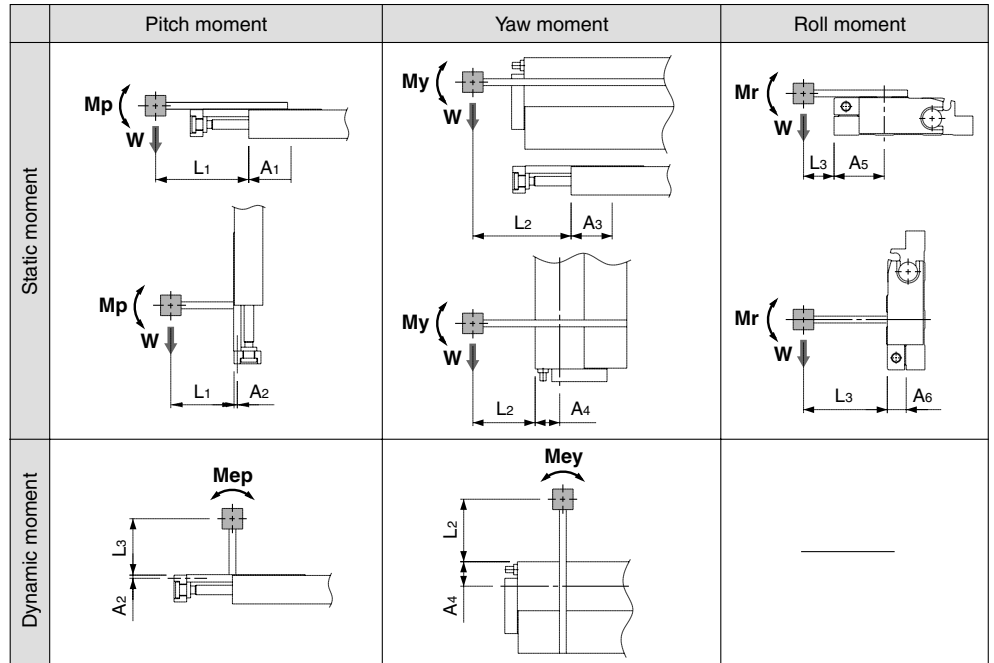

Fig. (2) Overhang: Ln (mm), Correction Values for Moment Center Distance: An (mm)



Note) Static moment: Moment generated by gravity
Dynamic moment: Moment generated by impact when colliding with stopper

Table (1) Maximum Allowable Kinetic Energy: Emax (J)

Model	Allowable kinetic energy
	Rubber bumper
MXF8	0.027
MXF12	0.055
MXF16	0.11
MXF20	0.16

Graph (1) Allowable Load Mass Coefficient: β

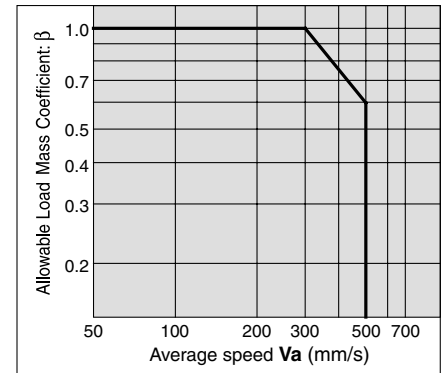

Table (2) Maximum Allowable Load mass: Wmax (kg)

Model	Maximum allowable load mass
MXF8	0.6
MXF12	1
MXF16	2
MXF20	4

Table (3) Moment Center Position Distance Compensation Amount: An (mm)

Model	Moment center position distance compensation amount (Refer to Fig. (2).)					
	A1	A2	A3	A4	A5	A6
MXF8	6 ^{Note)}	10	6 ^{Note)}	21	21	10
MXF12	10	11	10	23	23	11
MXF16	10	12	10	28	28	12
MXF20	11	17	11	34	34	17

Note) 16 mm for MXF8-10 only.

Graph (2) Allowable Moment Coefficient: γ

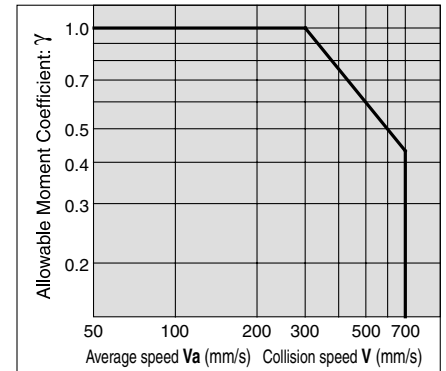

Note) Use the average speed when calculating static moment.
Use the collision speed when calculating dynamic moment.

Table (4) Maximum Allowable Moment: Mmax (N·m)

Model	Stroke (mm)						
	10	20	30	50	75	100	
MXF8	0.56	0.78	0.98	—	—	—	
MXF12	—	1.65	2.22	3.34	—	—	
MXF16	—	—	3.41	5.69	7.96	—	
MXF20	—	—	6.66	9.14	13.70	18.27	

Symbol

Symbol	Definition	Unit	Symbol	Definition	Unit
An (n = 1 to 6)	Correction values of moment center position distance	mm	Va	Average speed	mm/s
E	Kinetic energy	J	W	Load mass	kg
Ea	Allowable kinetic energy	J	Wa	Allowable load mass	kg
Emax	Max. allowable kinetic energy	J	We	Mass equivalent to impact	kg
Ln (n = 1 to 3)	Overhang	mm	Wmax	Max. allowable load mass	kg
M (Mp, My, Mr)	Static moment (pitch, yaw, roll)	N·m	α	Load factor	—
Ma (Map, May, Mar)	Allowable static moment (pitch, yaw, roll)	N·m	β	Allowable load mass coefficient	—
Me (Mep, Mey)	Dynamic moment (pitch, yaw)	N·m	γ	Allowable moment coefficient	—
Mea (Meap, Meay)	Allowable dynamic moment (pitch, yaw)	N·m	δ	Damper coefficient	—
Mmax (Mpmmax, Mymmax, Mrmax)	Maximum allowable moment (pitch, yaw, roll)	N·m	K	Workpiece mounting coefficient	—
V	Collision speed	mm/s			

- MXH
- MXU
- MXS
- MXQ
- MXF**
- MXW
- MXJ
- MXP
- MXY
- MTS

- D-□
- X□
- Individual -X□

Low Profile Slide Table Series *MXF*

How to Order

Low Profile Slide Table

MXF 12 - 50 - M9BW [] - []

Bore size/
Stroke (mm)

ø8	10, 20, 30
ø12	20, 30, 50
ø16	30, 50, 75
ø20	30, 50, 75, 100

Number of
auto switches

Nil	2 pcs.
S	1 pc.
n	"n" pcs.

Made to Order
Refer to page 137 for details.

Auto switch

Nil	Without auto switch (Built-in magnet)
-----	---------------------------------------

* For the applicable auto switch model, refer to the table below.

How to Order Stroke Adjusting Bolt (Accessory)

MXF - A 16 27 - X11

Applicable
bore size

8	ø8
12	ø12
16	ø16
20	ø20

Adjustment range

Nil	5 mm	Standard
X11	15 mm	Option
X12	25 mm	

* -X12 (adjustable range 25 mm) is not available in Series MXF8/MXF12.

Applicable Auto Switch/Refer to pages 1719 to 1827 for the detailed specifications of auto switches.

Type	Special function	Electrical entry	Indicator light	Wiring (Output)	Load voltage		Auto switch model		Lead wire length (m)				Pre-wired connector	Applicable load		
					DC	AC	Perpendicular	In-line	0.5 (Nil)	1 (M)	3 (L)	5 (Z)		IC circuit	Relay, PLC	
Solid state switch	Diagnostic indication (2-color indication)	Grommet	Yes	3-wire (NPN)	24 V	5 V, 12 V	—	M9NV	M9N	●	●	●	○	○	IC circuit	Relay, PLC
				3-wire (PNP)				M9PV	M9P	●	●	●	○	○		
				2-wire	5 V, 12 V	M9BV		M9B	●	●	●	○	○	IC circuit		
				3-wire (NPN)		M9NVV		M9NV	●	●	●	○	○			
				3-wire (PNP)	M9PWV	M9PW		●	●	●	○	○	—			
				2-wire	M9BWV	M9BW		●	●	●	○	○				
Reed switch	—	Grommet	Yes	3-wire (NPN equivalent)	—	5 V	—	A96V	A96	●	—	●	—	—	IC circuit	—
				2-wire	24 V	12 V	100 V	A93V	A93	●	—	●	—	—	—	IC circuit
			No				100 V or less	A90V	A90	●	—	●	—	—	IC circuit	Relay, PLC

* Lead wire length symbols: 0.5 m Nil (Example) M9NW
 1 m M (Example) M9NWM
 3 m L (Example) M9NWL
 5 m Z (Example) M9NWZ

* Solid state auto switches marked with "○" are produced upon receipt of order.

* Since there are other applicable auto switches than listed, refer to page 145 for details.
 * For details about auto switches with pre-wired connector, refer to pages 1784 and 1785.
 * Auto switches are shipped together (not assembled).

Specifications

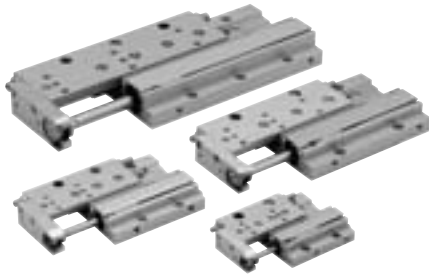

Bore size (mm)	8	12	16	20
Piping port size	M3 x 0.5	M5 x 0.8		
Fluid	Air			
Action	Double acting			
Operating pressure	0.15 to 0.7 MPa			
Proof pressure	1.05 MPa			
Ambient and fluid temperature	-10 to 60 °C			
Piston speed	50 to 500 mm/s			
Cushion	Rubber bumper on both sides			
Lubrication	Non-lube			
Auto switch (Option)	Reed auto switch Solid state auto switch (2-wire, 3-wire) 2-color indication solid state auto switch (2-wire, 3-wire)			
Stroke length tolerance	$^{+1}_0$ mm			
Stroke adjustment range	Extension end 5 mm/Retraction end 5 mm			

MXH

MXU

MXS

MXQ

MXF

MXW

MXJ

MXP

MXY

MTS

Theoretical Output

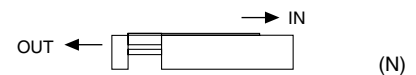

Bore size (mm)	Rod size (mm)	Operating direction	Piston area (mm ²)	Operating pressure (MPa)					
				0.2	0.3	0.4	0.5	0.6	0.7
8	4	OUT	50	10	15	20	25	30	35
		IN	38	8	11	15	19	23	27
12	6	OUT	113	23	34	45	57	68	79
		IN	85	17	26	34	43	51	60
16	8	OUT	201	40	60	80	101	121	141
		IN	151	30	45	60	76	91	106
20	10	OUT	314	63	94	126	157	188	220
		IN	236	47	71	94	118	142	165

Note) Theoretical output (N) = Pressure (MPa) x Piston area (mm²)



Made to Order Specifications
(For details, refer to pages 1955 to 2021.)

Symbol	Specifications
-X7	PTFE grease
-X9	Grease for food
-X11	Adjusting bolt, long specification (Adjustment range: 15 mm)
-X33	Without built-in auto switch magnet
-X39	Fluororubber seal
-X42	Anti-corrosive specifications for guide unit
-X45	EPDM seal

Standard Stroke

Model	Standard stroke (mm)
MXF8	10, 20, 30
MXF12	20, 30, 50
MXF16	30, 50, 75
MXF20	30, 50, 75, 100

Mass

(g)

Model	Standard stroke (mm)					
	10	20	30	50	75	100
MXF8	120	130	170	—	—	—
MXF12	—	210	250	360	—	—
MXF16	—	—	360	500	690	—
MXF20	—	—	600	750	1060	1370

D-□

-X□

Individual
-X□

Series MXF

Table Deflection (Reference Values)

Table displacement due to pitch moment load

Table displacement when loads are applied to the section marked with the arrow at the full stroke.

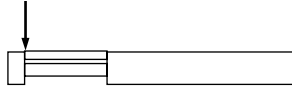

MXF 8

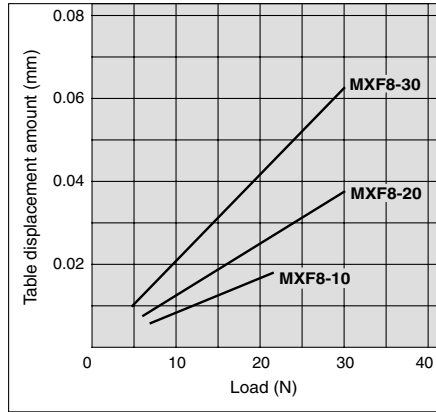

Table displacement due to yaw moment load

Table displacement when loads are applied to the section marked with the arrow at the full stroke.

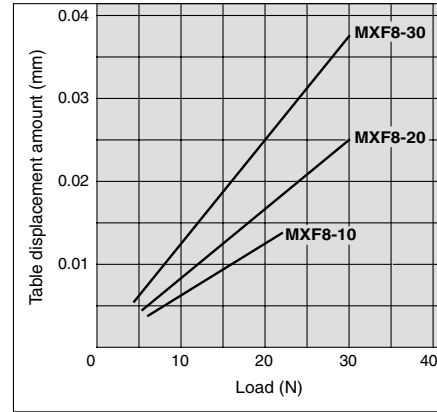
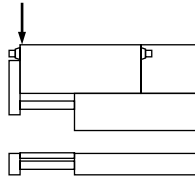
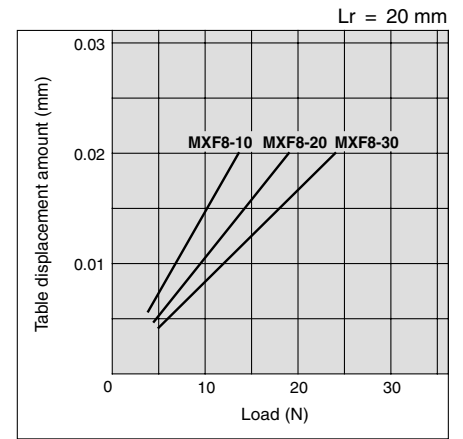
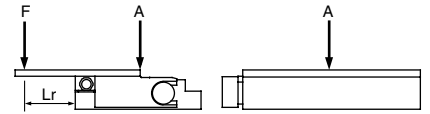
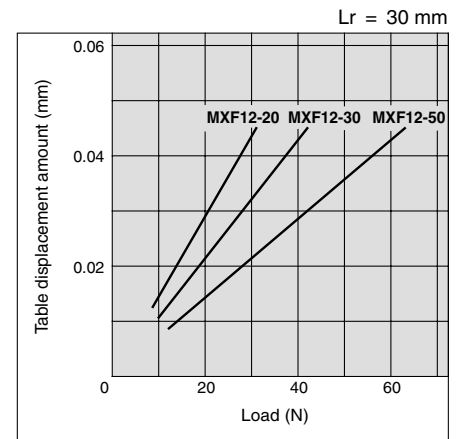
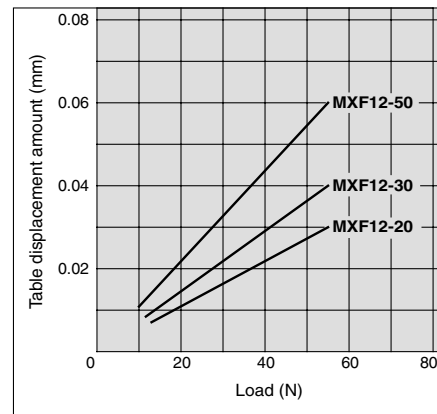
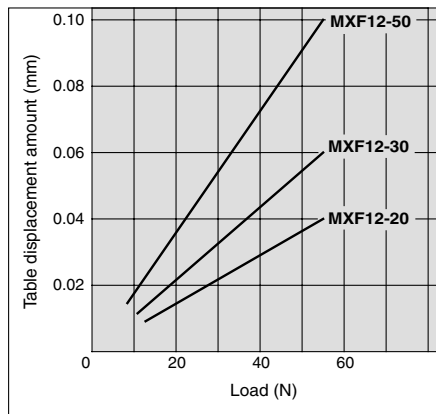

Table displacement due to roll moment load

Table displacement of section A when loads are applied to the section F with the slide table retracted.



MXF 12



Low Profile Slide Table *Series MXF*

The graphs below show the table displacement when the static moment load is applied to the table. The graphs do not show the loadable mass. Refer to the Model Selection for the loadable mass.

Table displacement due to pitch moment load

Table displacement when loads are applied to the section marked with the arrow at the full stroke.

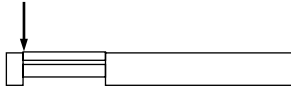

MXF 16

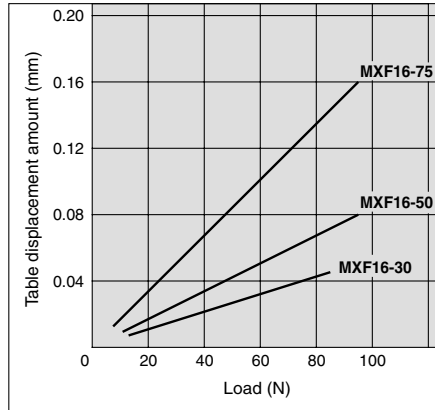

Table displacement due to yaw moment load

Table displacement when loads are applied to the section marked with the arrow at the full stroke.

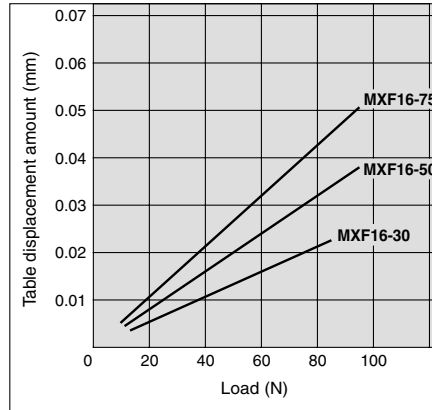
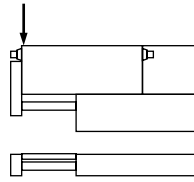
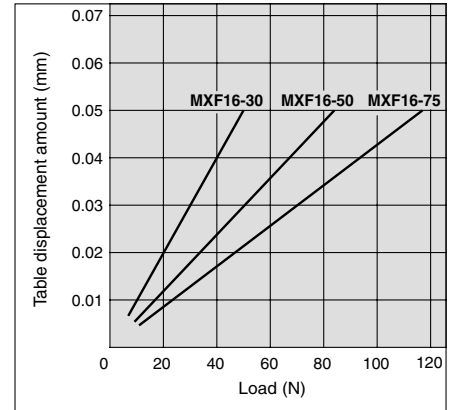
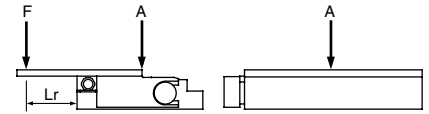
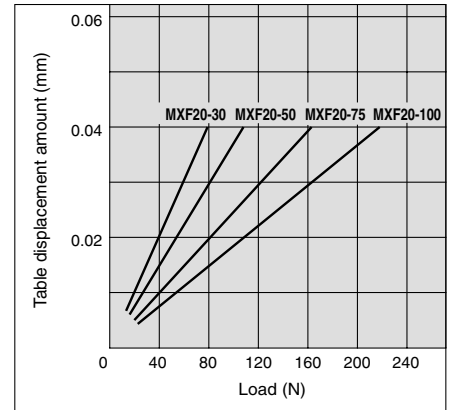
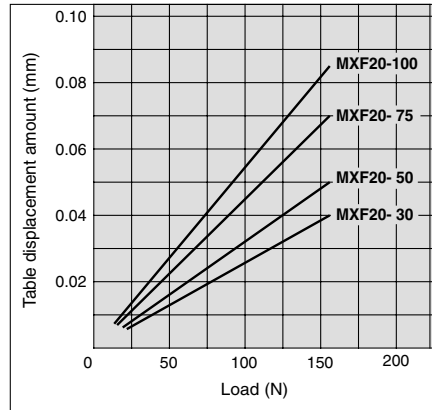
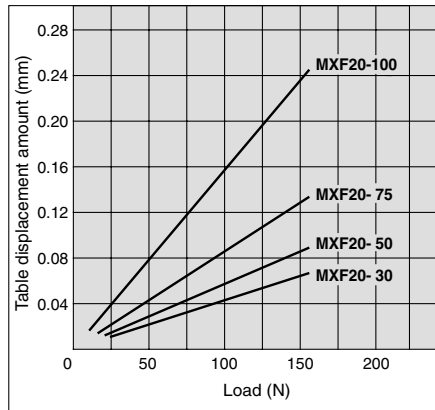

Table displacement due to roll moment load

Table displacement of section A when loads are applied to the section F with the slide table retracted.



MXF 20



- MXH
- MXU
- MXS
- MXQ
- MXF**
- MXW
- MXJ
- MXP
- MXY
- MTS

- D-□
- X□
- Individual -X□

Series MXF

Construction

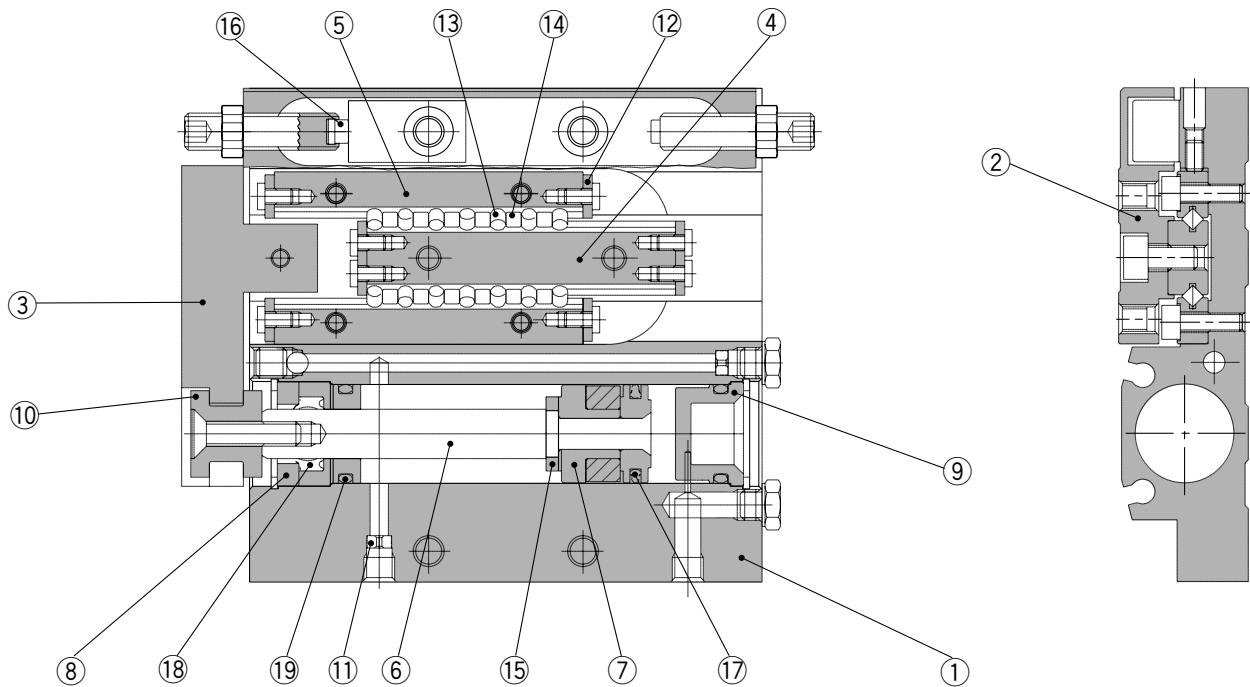

Component Parts

No.	Description	Material	Note
1	Body	Aluminum alloy	Hard anodized
2	Table	Aluminum alloy	Hard anodized
3	End plate	Aluminum alloy	Hard anodized
4	Rail	Carbon tool steel	Heat treated
5	Guide	Carbon tool steel	Heat treated
6	Rod	Stainless steel	
7	Piston assembly	—	With magnet
8	Seal support	Brass	Electroless nickel plated
9	Head cap	Resin	
10	Floating bushing	Stainless steel	
11	Orifice	Brass	Electroless nickel plated
12	Roller stopper	Stainless steel	
13	Cylindrical roller	High carbon chrome bearing steel	
14	Roller spacer	Resin	
15	Rod bumper	Polyurethane	

Component Parts

No.	Description	Material	Note
16	Adjust bumper	Polyurethane	
17	Piston seal	NBR	
18	Rod seal	NBR	
19	O-ring	NBR	

Replacement Parts: Seal Kit

Bore size (mm)	Kit no.	Contents
8	MXF8-PS	Set of nos. above 17 to 19
12	MXF12-PS	
16	MXF16-PS	
20	MXF20-PS	

* Seal kit includes 17, 18, 19. Order the seal kit, based on each bore size.

Replacement Part: Grease Pack

Applied part	Grease pack part no.
Guide	GR-S-005 (5 g)
	GR-S-010 (10 g)
	GR-S-020 (20 g)
	GR-S-050 (50 g)
Cylinder	GR-L-005 (5 g)
	GR-L-010 (10 g)
	GR-L-020 (20 g)
	GR-L-050 (50 g)

Dimensions: Stroke Adjusting Bolt

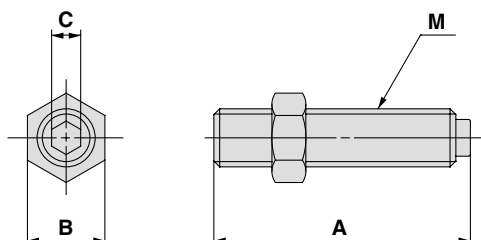

Applicable size	Model	Stroke adjustable range (mm)	A	B	C	M
MXF8	MXF-A827	5	17	6	2	M4 x 0.7
	MXF-A827-X11	15	27			
MXF12	MXF-A1227	5	23.5	7	2.5	M5 x 0.8
	MXF-A1227-X11	15	33.5			
	MXF-A1627	5	26.5			
MXF16	MXF-A1627-X11	15	36.5	8	3	M6 x 1
	MXF-A1627-X12	25	46.5			
	MXF-A2027	5	30			
MXF20	MXF-A2027-X11	15	40	12	4	M8 x 1
	MXF-A2027-X12	25	50			

Dimensions: MXF8

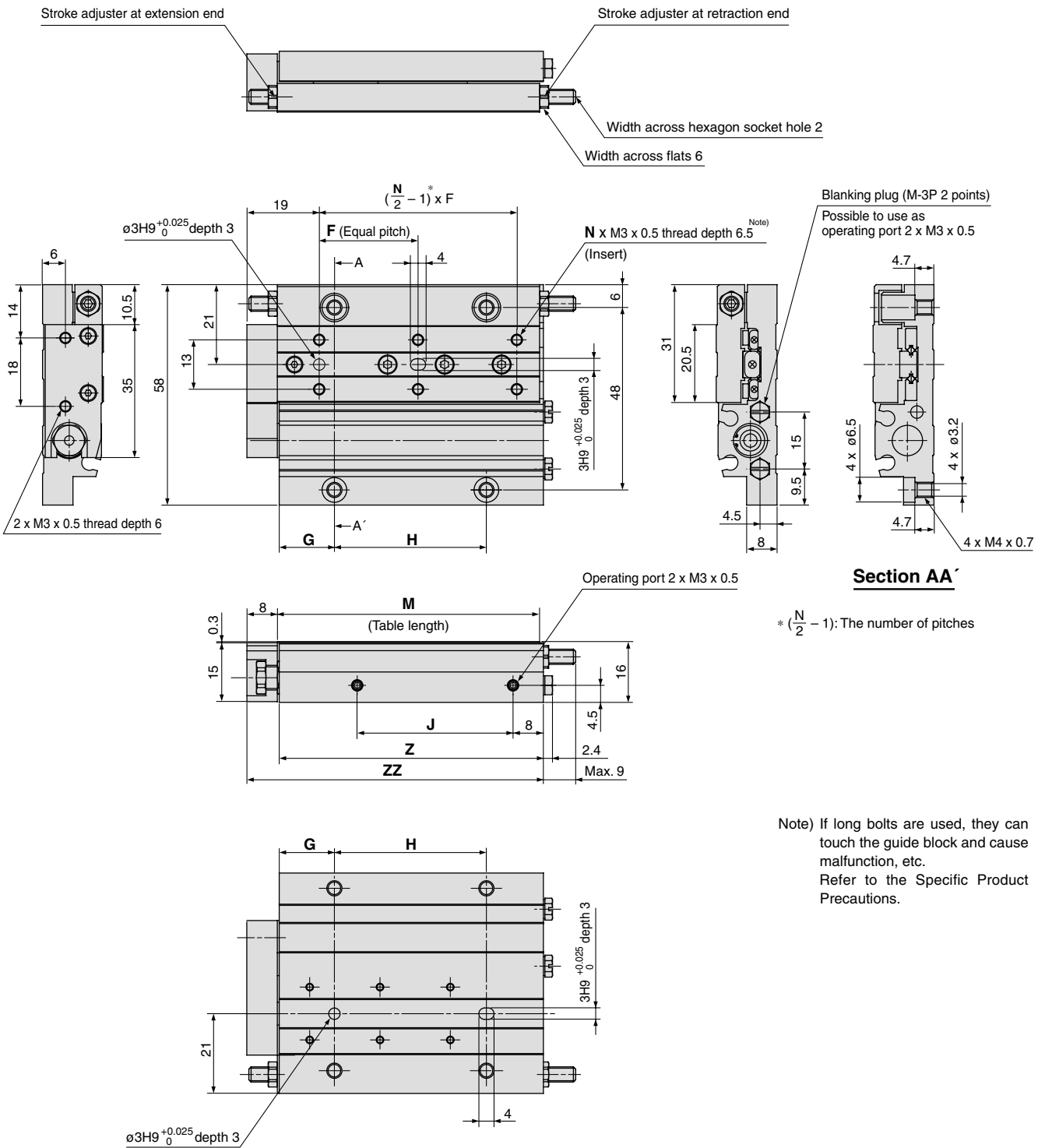

- MXH
- MXU
- MXS
- MXQ
- MXF**
- MXW
- MXJ
- MXP
- MXY
- MTS

(mm)

Model	F	N	G	H	J	M	Z	ZZ
MXF8-10	20	4	13.5	22	21	49	49.5	58
MXF8-20	26	4	14.5	26	26	54	54.5	63
MXF8-30	26	6	14.5	40	41	69	69.5	78

- D-□
- X□
- Individual
-X□

Series MXF

Dimensions: MXF12

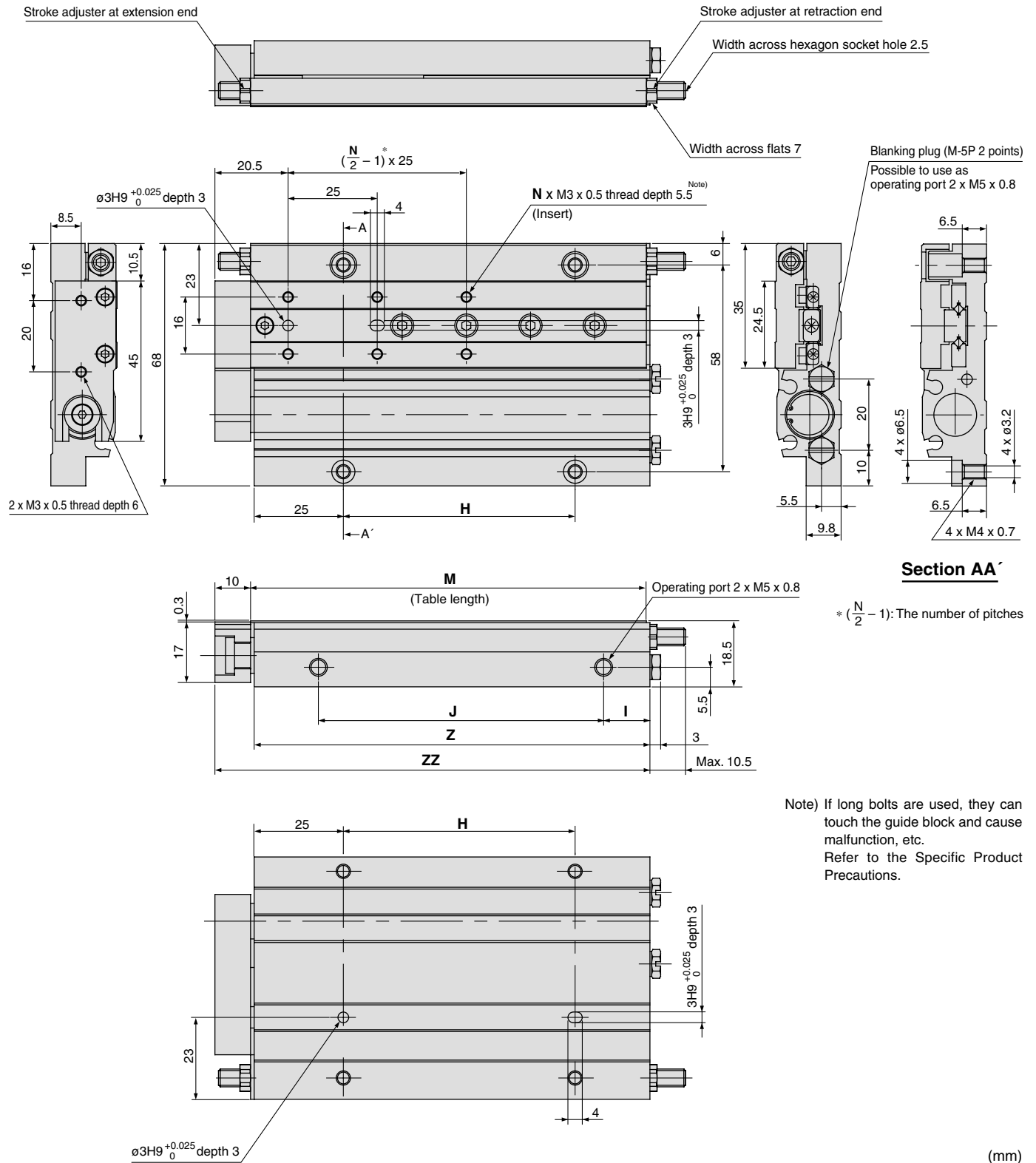

(mm)

Model	N	H	I	J	M	Z	ZZ
MXF12-20	4	22	11	36	65	65	76
MXF12-30	4	30	12	45	75	75	86
MXF12-50	6	65	13	80	111	111	122

Dimensions: MXF16

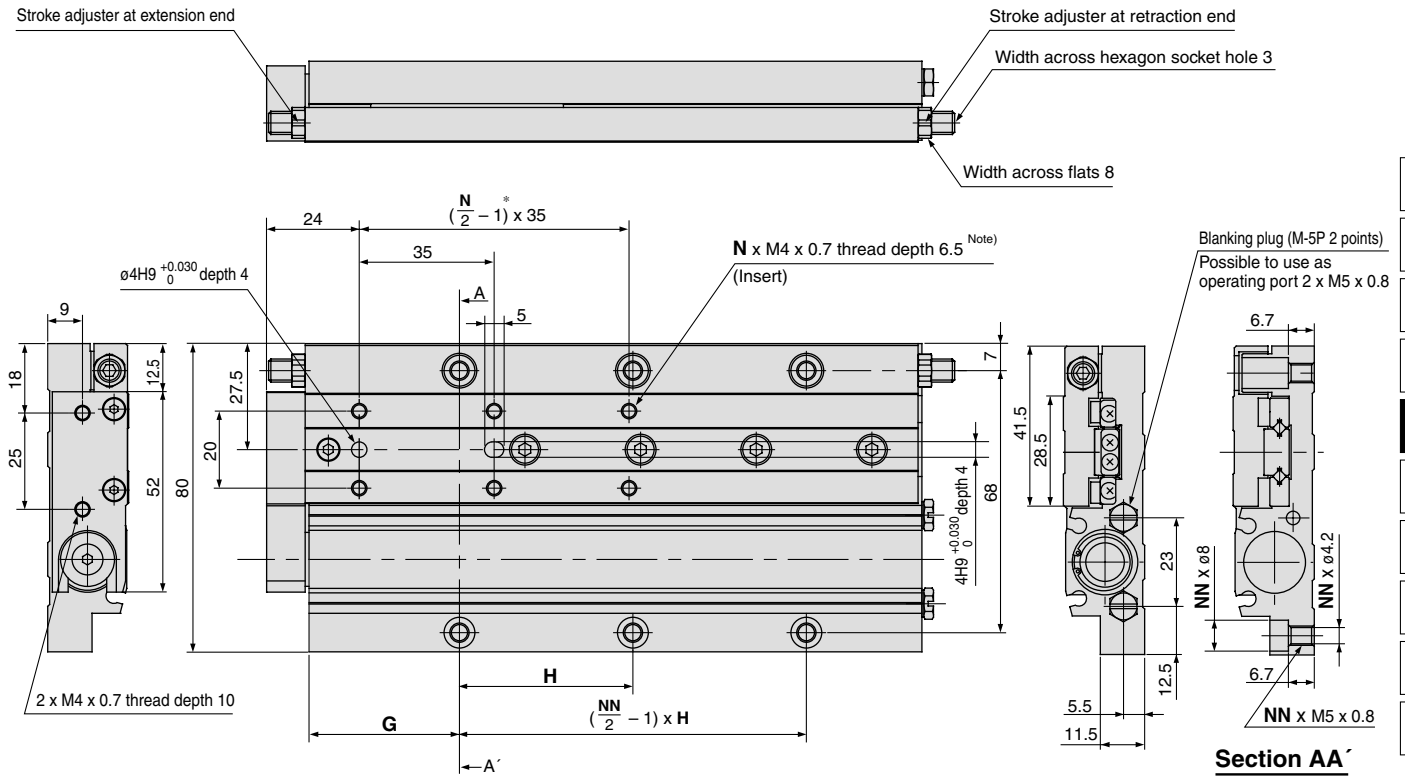

- MXH
- MXU
- MXS
- MXQ
- MXF**
- MXW
- MXJ
- MXP
- MXY
- MTS

* $(\frac{N}{2} - 1)$: The number of pitches

Note) If long bolts are used, they can touch the guide block and cause malfunction, etc. Refer to the Specific Product Precautions.

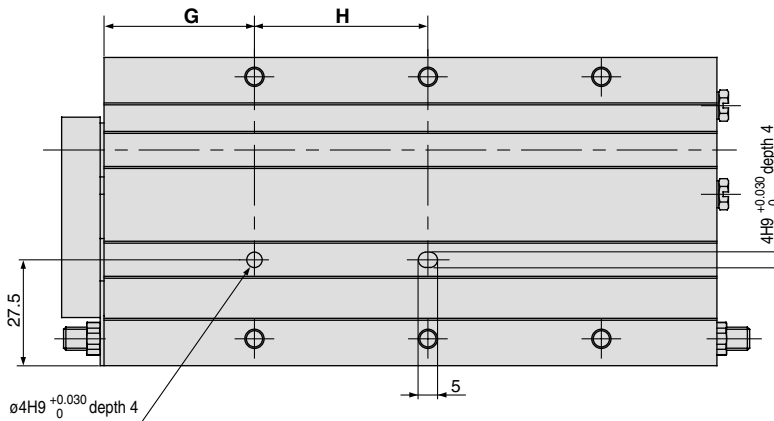

Model	N	G	H	NN	I	J	M	Z	ZZ
MXF16-30	4	29	25	4	12	50	83	83	94
MXF16-50	6	29	55	4	12	80	113	113	124
MXF16-75	6	39	45	6	13	125	159	159	170

(mm)

D-

-X

Individual
-X

Series MXF

Dimensions: MXF20

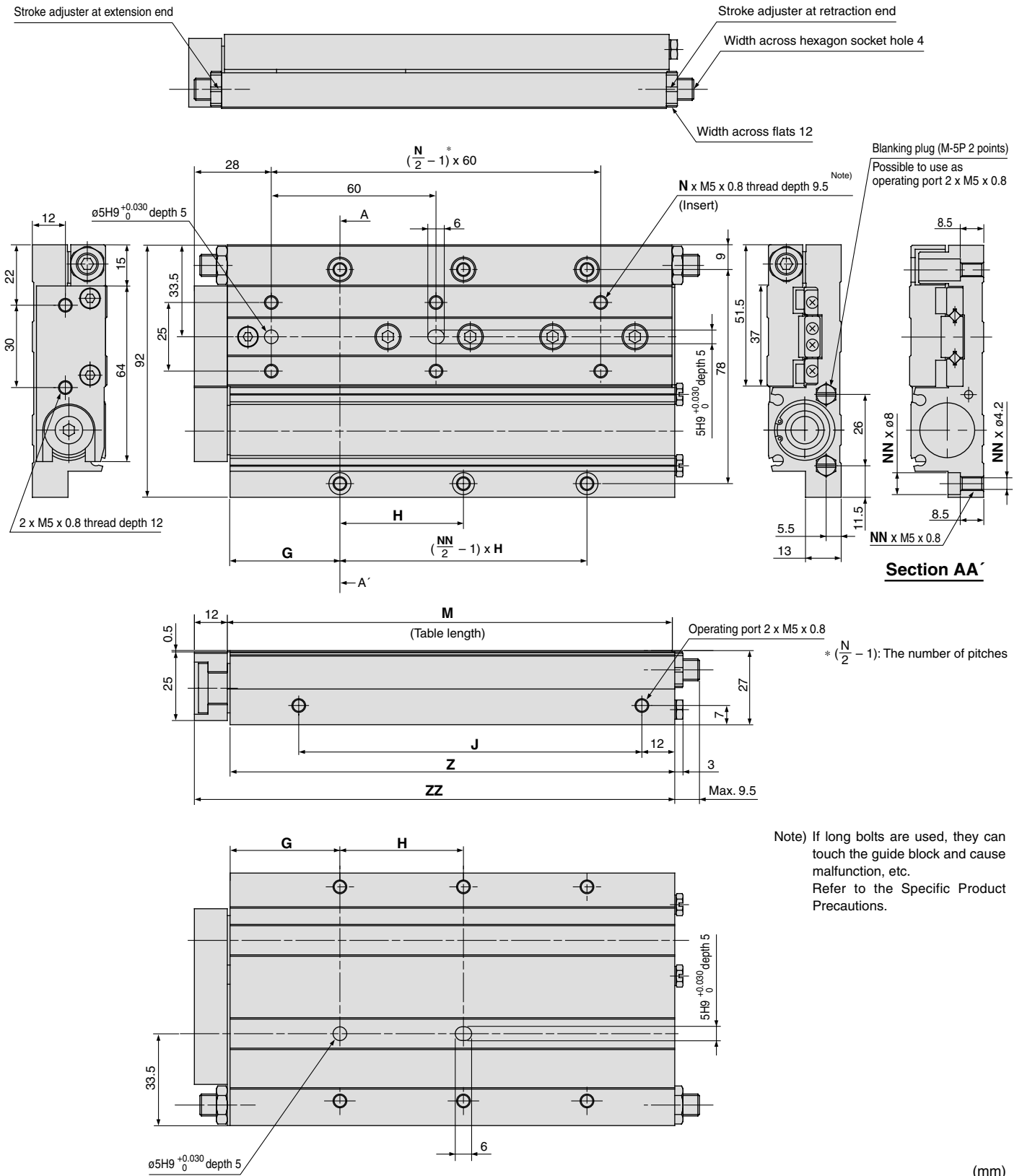

Model	N	G	H	NN	J	M	Z	ZZ
MXF20-30	4	29	30	4	57	91	91	104
MXF20-50	4	36	45	4	77	113	113	126
MXF20-75	6	40	45	6	125	162	162	175
MXF20-100	6	59	60	6	175	211	211	224

Auto Switch Proper Mounting Position (Detection at Stroke End)

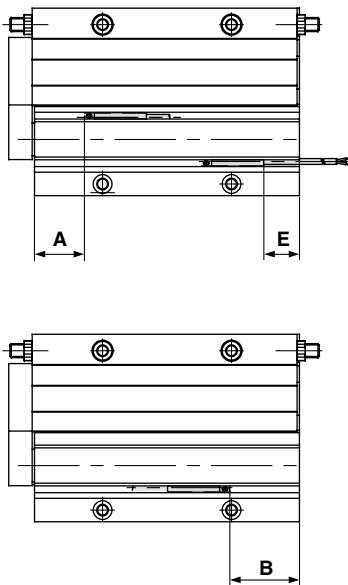

Reed Auto Switch: D-A90, D-A93, D-A96, D-A90V, D-A93V, D-A96V (mm)

Model	A	B						E					
		Stroke						Stroke					
		10	20	30	50	75	100	10	20	30	50	75	100
MXF8	9.5	10	5	10	—	—	—	8 (5.5)	3 (0.5)	8 (5.5)	—	—	—
MXF12	12	—	13.1	13.1	29.1	—	—	—	11.1 (8.6)	11.1 (8.6)	27.1 (24.6)	—	—
MXF16	17.2	—	—	15.8	25.8	46.8	—	—	—	13.8 (11.3)	23.8 (21.3)	44.8 (42.3)	—
MXF20	19.4	—	—	20.7	22.7	46.2	70.7	—	—	18.7 (16.2)	20.7 (18.2)	44.2 (41.7)	68.7 (66.2)

Solid State Auto Switch: D-M9B, D-M9N, D-M9P, D-M9BW, D-M9NW, D-M9PW (mm)

Model	A	B						E					
		Stroke						Stroke					
		10	20	30	50	75	100	10	20	30	50	75	100
MXF8	13.5	14	9	14	—	—	—	4	-1	4	—	—	—
MXF12	16	—	17.1	17.1	33.1	—	—	—	7.1	7.1	23.1	—	—
MXF16	21.2	—	—	19.8	29.8	50.8	—	—	—	9.8	19.8	40.8	—
MXF20	23.4	—	—	24.7	26.7	50.2	74.7	—	—	14.7	16.7	40.2	64.7

Solid State Auto Switch: D-M9BV, D-M9NV, D-M9PV, D-M9BWV, D-M9NWV, D-M9PWV (mm)

Model	A	B						E					
		Stroke						Stroke					
		10	20	30	50	75	100	10	20	30	50	75	100
MXF8	13.5	14	9	14	—	—	—	6	1	6	—	—	—
MXF12	16	—	17.1	17.1	33.1	—	—	—	9.1	9.1	25.1	—	—
MXF16	21.2	—	—	19.8	29.8	50.8	—	—	—	11.8	21.8	42.3	—
MXF20	23.4	—	—	24.7	26.7	50.2	74.7	—	—	16.7	18.7	42.2	66.7



* (): Denotes the values of D-A93.
Note) Adjust the auto switch after confirming the operating conditions in the actual setting.

MXH
MXU
MXS
MXQ
MXF
MXW
MXJ
MXP
MXY
MTS

Auto Switch Mounting



Auto Switch Mounting Tool

- When adjusting the auto switch mounting screw (included with auto switch), use a watchmaker's screwdriver with a handle about 5 to 6 mm in diameter.

Tightening Torque

Tightening Torque of Auto Switch Mounting Screw (N·m)

Auto switch model	Tightening torque
D-A9□(V)	0.10 to 0.20
D-M9□(V)	0.05 to 0.15
D-M9□W(V)	

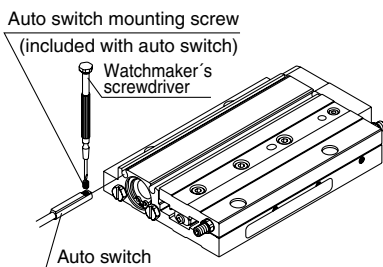

Operating Range

Auto switch model	Applicable bore size (mm)			
	8	12	16	20
D-A9□(V)	4.5	5	6	7
D-M9□, M9□V D-M9□W, M9□WV	3	3	4.5	5

* Since the operating range is provided as a guideline including hysteresis, it cannot be guaranteed (assuming approximately ±30% dispersion). It may vary substantially depending on an ambient environment.

Other than the models listed in "How to Order", the following auto switches are applicable.

- * Normally closed (NC = b contact) solid state auto switches (D-F9G/F9H types) and solid state auto switch D-F8 are also available. For details, refer to pages 1745 and 1746.

D-□
-X□
Individual
-X□



Series MXF Specific Product Precautions

Be sure to read before handling. Refer to front matters 42 and 43 for Safety Instructions and pages 3 to 11 for Actuator and Auto Switch Precautions.

Mounting

⚠ Caution

- Do not scratch or dent the mounting side of the body, table or end plate. It causes play in the guide section and increases sliding resistance.
- Do not scratch or dent on the forward side of the rail or guide. It will result in looseness of the guide section and increased sliding resistance.
- Keep away from objects which are influenced by magnets.
As the piston part has magnets built-in, do not allow close contact with magnetic disks, magnetic cards or magnetic tapes. Data may be erased.
- When mounting the body, use screws with appropriate length and do not exceed the maximum tightening torque. Tightening with a torque above the limit could malfunction. Whereas tightening insufficiently could result in misalignment or come to a drop.
- Be careful when adjusting stroke not to allow cylinder end plate to bottom out against cylinder body.

Mounting of Body

The slide table can be mounted from 2 directions. Select the best direction according to your application.

1. Body Tapped

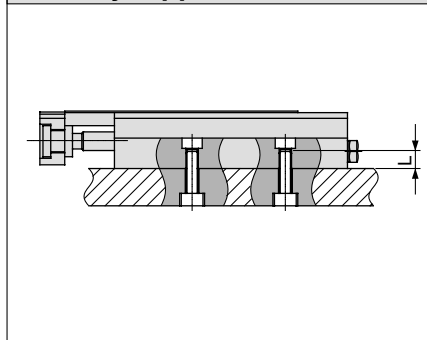

Model	Bolt	Maximum tightening torque (N·m)	Maximum screw-in depth L (mm)
MXF8	M4 x 0.7	2.1	4.7
MXF12	M4 x 0.7	2.1	6.5
MXF16	M5 x 0.8	4.4	6.7
MXF20	M5 x 0.8	4.4	8.5

2. Body Through-hole

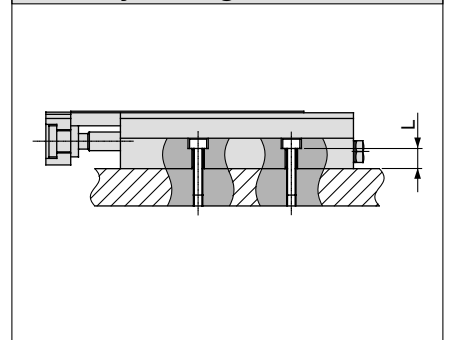

Model	Bolt	Maximum tightening torque (N·m)	Maximum screw-in depth L (mm)
MXF8	M3 x 0.5	1.2	4.7
MXF12	M3 x 0.5	1.2	6.5
MXF16	M4 x 0.7	2.8	6.7
MXF20	M4 x 0.7	2.8	8.5

⚠ Caution

0.02 mm or less of flatness is recommended for the body mounting surface. An uneven mounting surface of a workpiece or a base may cause vibration or increase sliding resistance.

Positioning

⚠ Caution

- The positioning hole on the table and on the bottom of the body does not have the same center. Positioning hole is meant to be for reproducibility for mounting and dismounting.

Selection

⚠ Caution

- If intermediate stop by external stopper is done, avoid ejection.**
If ejection occurs, it may cause damage. In the case the slide table is stopped at an intermediate position by an external stopper then forwarded to the front, return the slide table to the back for just a moment to retract the stopper, then supply pressure to the opposite port to operate slide table.
- Do not use it in such a way that excessive external force or impact force could work on it.**
This could result in damage.

Mounting of Workpiece

Work can be mounted on two sides of the body.

1. Front Mounting

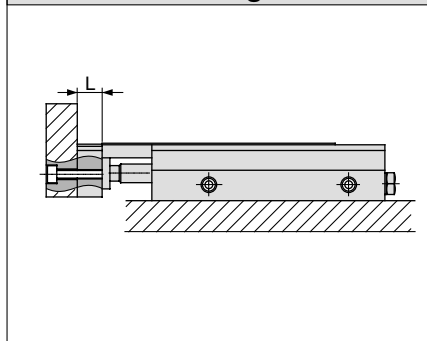

Model	Bolt	Maximum tightening torque (N·m)	Maximum screw-in depth L (mm)
MXF8	M3 x 0.5	0.9	6
MXF12	M3 x 0.5	0.9	6
MXF16	M4 x 0.7	2.1	10
MXF20	M5 x 0.8	4.4	12

2. Top Mounting

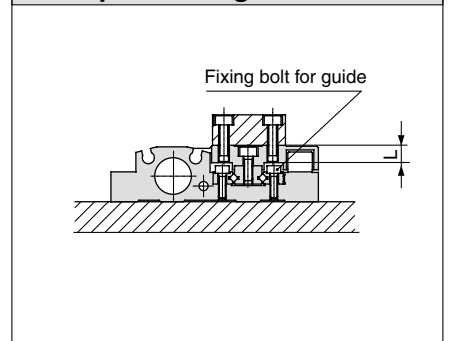

Model	Bolt	Maximum tightening torque (N·m)	Maximum screw-in depth L (mm)
MXF8	M3 x 0.5	0.9	6.5
MXF12	M3 x 0.5	0.9	5.5
MXF16	M4 x 0.7	2.1	6.5
MXF20	M5 x 0.8	4.4	9.5

⚠ Caution

To prevent the workpiece holding bolts from touching the guide holding bolts, use bolts that are 0.5 mm or more shorter than the maximum screw-in depth. If the bolts are too long, they hit the end plate and may cause malfunctions.