

Controller for Electro-Pneumatic Regulator

Series IC

Converts digital input signal into analog output signal

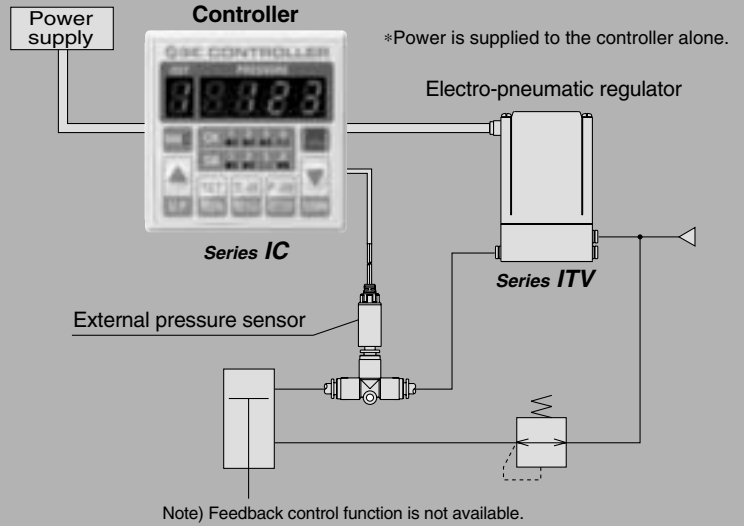

10 bit parallel input signal (maximum)

Pressure can be set with $2^{10} = 1024$ steps.

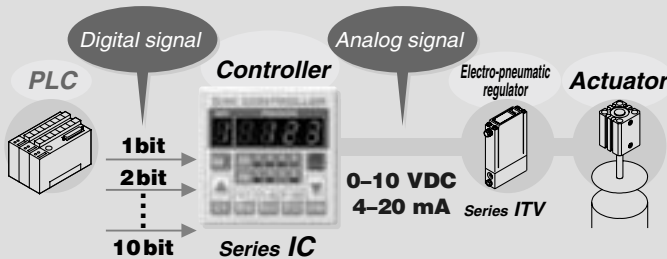
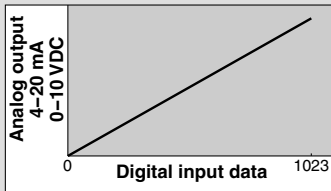

4 point preset output pressure

Applicable in the programming function with up to 20 steps.

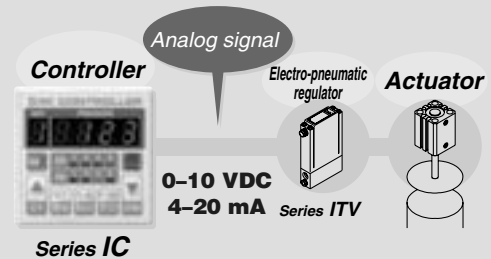
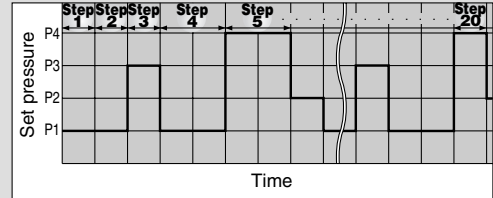

4 point pressure switch function

Switch output is enabled by setting the upper and lower limits of pressure.

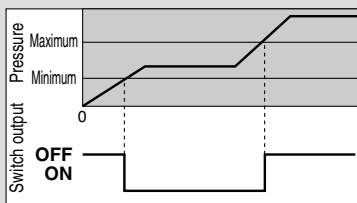

Power voltage and output signals

Output power voltage and output signal to the electro-pneumatic regulator can be set with keys on the front panel.

	Power supply voltage	Output signal
1	12 VDC	4 to 20 mA
2	12 VDC	0 to 10 VDC
3	24 VDC	4 to 20 mA
4	24 VDC	0 to 10 VDC

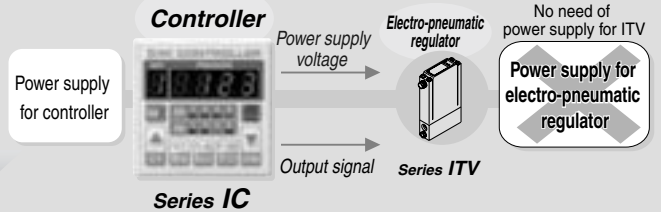

This product is mainly used in combination with Series ITV0000 without a display function.

- ARJ
- AR425 to 935
- AMR
- ARM
- ARP
- IR
- IRV
- VEX1□
- SRH
- SRP
- SRF
- ARX20
- VCHR
- ITV
- IC
- PVQ
- VEF VEP
- VER
- VEA
- VY2
- VBA VBAT
- AP100

Controller for Electro-Pneumatic Regulator *Series IC*

How to Order

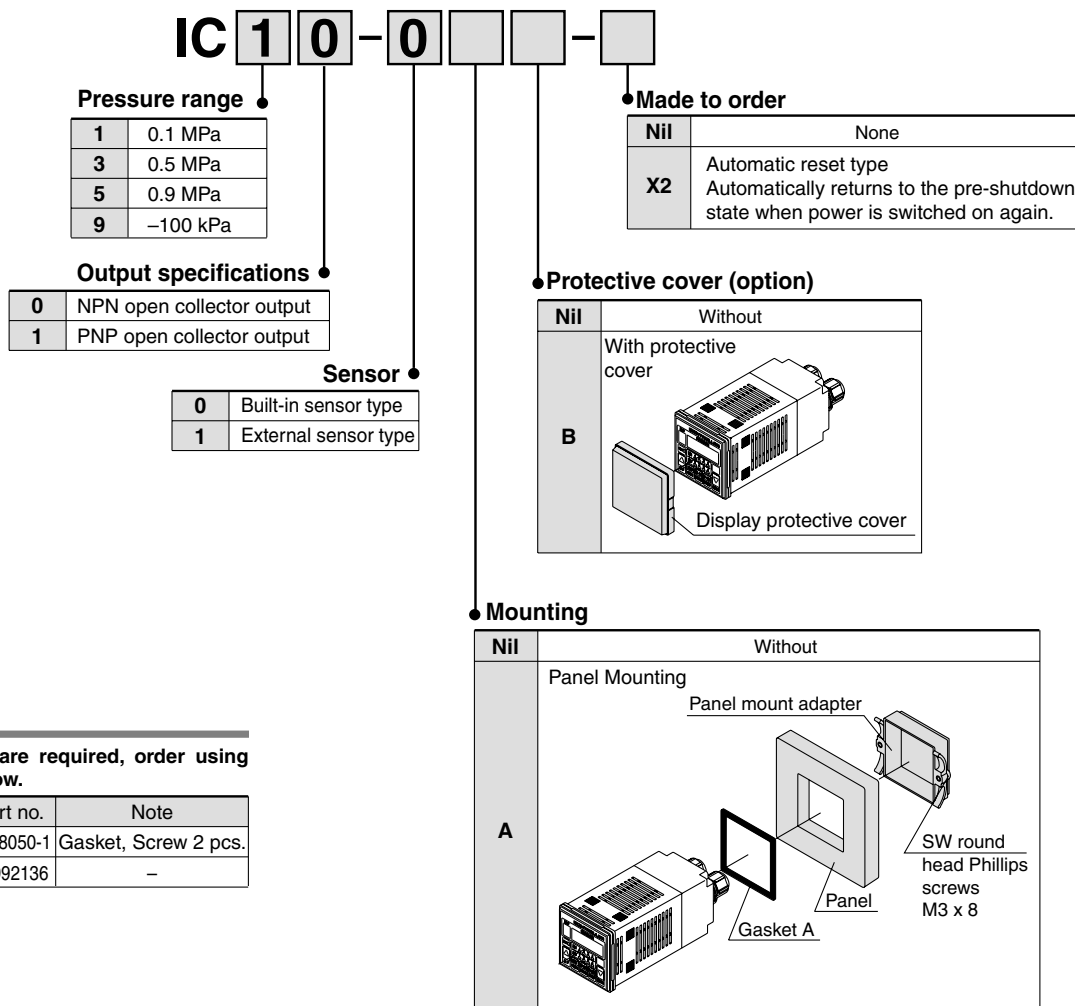

Option

When only optional parts are required, order using the part numbers listed below.

Description	Part no.	Note
Panel mount adapter set	P398050-1	Gasket, Screw 2 pcs.
Display protective cover	P2992136	-



Specifications

Model	IC1□	IC3□	IC5□	IC9□
Pressure range	0.1 MPa	0.5 MPa	0.9 MPa	-0.1 MPa
Proof pressure	500 kPa	1.5 MPa		500 kPa
Fluid	Air/Non-corrosive gas			
Dimensions	48 x 48 x 100.5			
Power supply	12 to 24 VDC (15 W or more), Ripple (p-p) 1% or less			
Input	① No. of inputs: Up to 10 bit input from sequencer (parallel) Input method: No-voltage contact or NPN open collector input Minimum pulse width: 50 msec ② Input method: 4 point input with keys (Interval time can be set by programming.)			
Power supply output	12 VDC (Max. 300 mA) with accuracy of 12 to 14.4 VDC ^{Note 2)} 24 VDC (Max. 300 mA) with accuracy of 22.0 to 26.8 VDC			
Command output	① 0 to 10 VDC (Output resistance: 6.5 kΩ or more with accuracy of 0.5%F.S. or less) ② 4 to 20 mA (Output resistance: 800 Ω or less with accuracy of 0.5%F.S. or less)			
Switch output	Output: 4 points Output type: NPN, PNP open collector output Withstand voltage: Max. 30 V Current: Max. 100 mA Internal voltage drop: 1 V or less Switching between N.O. and N.C. modes is possible.			
Switch response	5 to 640 ms			
Display	Power indication: 3 1/2-digit LED indicator (red) Output power supply voltage and current signal indication: 1-digit LED indicator (red) LED lights for RUN, CH, SW (red and green)			
Display accuracy ^{Note 1)}	±0.5%F.S. ±1dig (at 25°C)			
Display sampling rate	Approx. 4 times/s			
Temperature characteristics	±0.12%F.S./°C			
Error indication	Displayed on pressure indication LED			
Resistance	Operating temperature range	0 to 50°C		
	Storage temperature range	-20 to 60°C		
	Operating humidity range	0 to 85%R.H.		
	Vibration resistance	10 to 55 Hz 1.5 mm amplitude X, Y, Z directions for 2 hrs. each		
	Impact resistance	100 m/s ² (approx. 10 G) X, Y, Z direction		
	Water resistance	Only display unit with cover is equivalent to IP65. It is equivalent IP40 without cover.		
Sensor type	Built-in sensor type, External sensor type ^{Note 3)}			
Set value retention	10 years when deenergized (EEPROM)			
Port size	M5 female (built-in sensor type)			
Material	Enclosure: POM Display: PC Gasket: NBR Panel mount adapter: POM Display protective cover: PC			
Mass	Approx. 330 g (Built-in sensor type) Approx. 345 g (External sensor type)			

Note 1) The display accuracy is the accuracy of the LED indication when the sensor port of the built-in sensor type is pressurized.

Note 2) The external sensor type has the same output power supply voltage specifications.

Note 3) The sensor for the external sensor type is not attached and must be ordered separately.

Any pressure sensor that transmits analog output signals can be connected.

Recommended sensor: Series PSE530 (For more information, please refer to Best Pneumatics No. 6.)

Note 4) Button operation is required when turning the power on again. However, the made-to-order specification (-X2) automatically returns to the pre-shutdown state when power is switched on again.

Note 5) For Series ITV1000 to 3000, a 10-bit input (parallel) through a sequencer is available as a made-to-order specification.

ARJ

AR425
to 935

AMR

ARM

ARP

IR

IRV

VEX1□

SRH

SRP

SRF

ARX20

VCHR

ITV

IC

PVQ

VEF
VEP

VER

VEA

VY2

VBA
VBAT

AP100

Functions

■ 4 point preset output

- Four points (CH1 to CH4) of pressure and switch output ranges can be set with the front panel keys.
- Up to 20 steps of programming is possible.
- Interval time (1 to 999 sec) can be set by programming.
- The set pressures can be arranged in a random order.

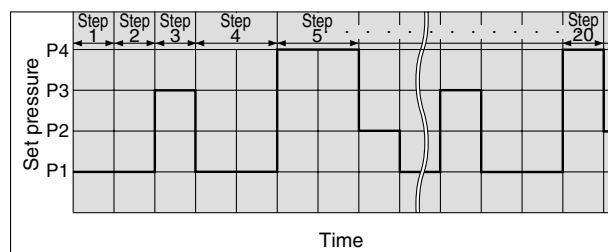

■ 10 bit parallel input

- Up to 10 bits of parallel input is possible from PLC.
- Pressure can be set with $2^{10} = 1024$ steps.

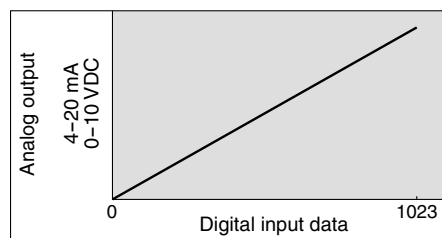

■ Pressure switch function (4 point)

Switch output is enabled by setting the upper and lower limits.

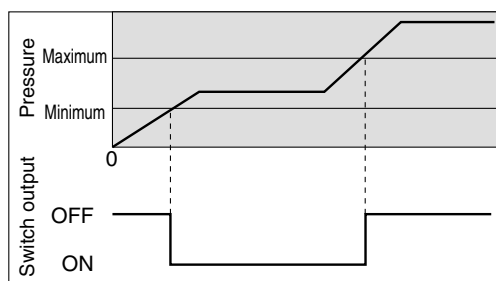

■ Power supply voltage and output signal switch function

- Output power supply voltage and output signal to the electro-pneumatic regulator can be selected with the front panel keys.
- No need of power supply for the electro-pneumatic regulator.
- Stable power supply is possible.

	Power supply voltage	Output signal
1	12 VDC	4 to 20mA
2	12 VDC	0 to 10 VDC
3	24 VDC	4 to 20mA
4	24 VDC	0 to 10 VDC

■ Set pressure correction function (only for 4 point preset input)

Either automatic or manual adjustment is possible in pressure adjustment mode.

<Automatic adjustment mode>

The controller automatically calculates the deviation and converts the correction value into the output signal. The deviation converges within the range of $\pm 0.5\%$ F.S.

Note) If the set pressure is 250 kPa and the output pressure on the pressure sensor is 245 kPa, the deviation is $250 - 245 = 5$ kPa. In order to correct the deviation, the controller increases the output signal until the pressure on the pressure sensor converges at 250 kPa.

<Manual adjustment mode>

The deviation is corrected manually (with keys).

■ Zero span correction function

Deviation of the zero span point of the sensor can be corrected.

■ Keypad lock function

To prevent erroneous operation, operation on the key can be disabled.

Keys which cannot be locked:



P-ON/STOP key



SET/RUN key

■ Reset function

The data is reset to the initial condition at the time of shipment.

■ Anti-chattering function

Large bore cylinders and ejectors consume a large volume of air in operation and occasionally experience temporary drops in supply pressure. This function prevents detection of such momentary supply pressure drops. It regards them as abnormalities and changes the response time settings.

Possible response time settings: 5 ms, 20 ms, 160 ms, 640 ms

<Principle>

The controller equalizes the pressures measured during the specified response time. It then compares the equalized pressure and the set pressure to output switch signals accordingly.

■ Error display

Error name	Error indication	Description
Overcurrent error	SW1 Er 1	Excess current is running through switch.
	SW2 Er 2	
	SW3 Er 3	
	SW4 Er 4	
Switch range error	Er 5	Lower limit of switch output exceeds upper limit.
Pressurization error	- - -	Pressure exceeding upper limit of set pressure is applied.

Descriptions

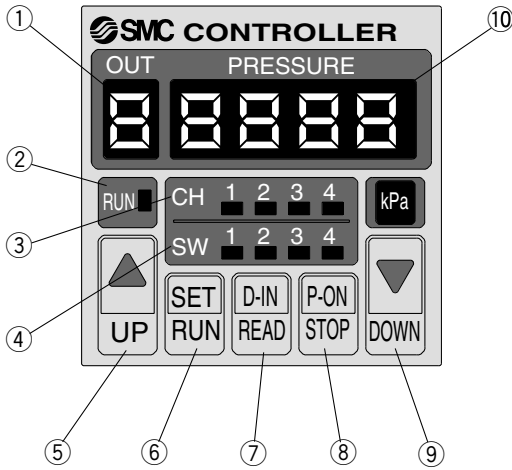

No.	Description
①	OUT display Displays output specification to electro-pneumatic regulator.
②	RUN display Displays control status.
③	CH channel (display) (for 4 point input) Of CH1 to CH4 for pressure selection, channel with output ON lights up.
④	SW (switch) output display Displays output type and output status of SW1 to 4.
⑤	UP button Used to change mode and set value.
⑥	SET/RUN button Used to confirm mode and set value, or to change to control ON state.
⑦	D-IN/READ button Used to select mode and turn on or off power supply to electro-pneumatic regulator.
⑧	P-ON/STOP button Used to turn on or off main power supply, escape from mode, or change to stand-by state.
⑨	DOWN button Used to change mode and set value.
⑩	Pressure display Displays measured value, settings, and error code.

IC□□-0□□(Internal sensor type) IC□□-1□□(External sensor type)

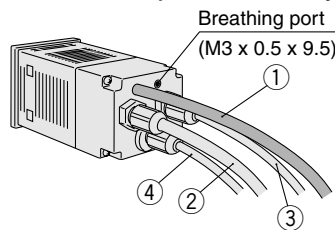
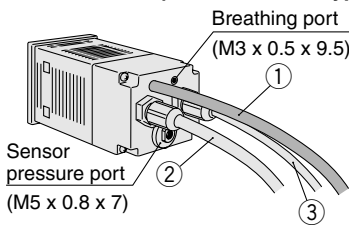

No.	Description	Note
①	Power supply, 10 bit input cable	13 wire, O.D. 6.8 mm, 1 m length
②	Cable for 4 point switch output	5 wire, O.D. 6 mm, 1 m length
③	Pneumatic regulator connection cable	3 wire, O.D. 3.4 mm, 1 m length
④	Cable for external sensor	

Note 1) Keep the bending radius of the cable greater than 50 mm.

Note 2) Since the electro-pneumatic regulator connection cable ③ and the cable for external sensor ④ are identical in shape, take precautions against erroneous connection.

Internal Circuit and Connection

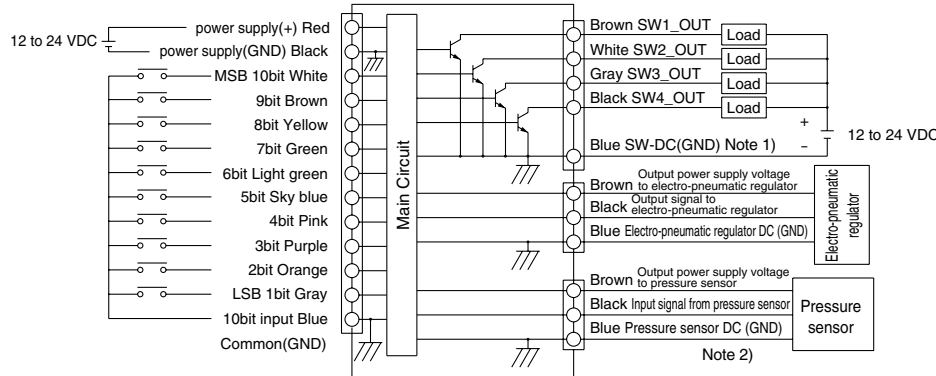

For the setting procedure and detailed cable connection specifications, please refer to the instruction manual.

IC□□-0□□ (NPN open collector output type)

Note 1) If the power supply for loads and main power supply are provided by a common source, the power supply (GND) can be used for SW-DC (GND).

Note 2) Connection to the pressure sensor is required only when using the external sensor type.

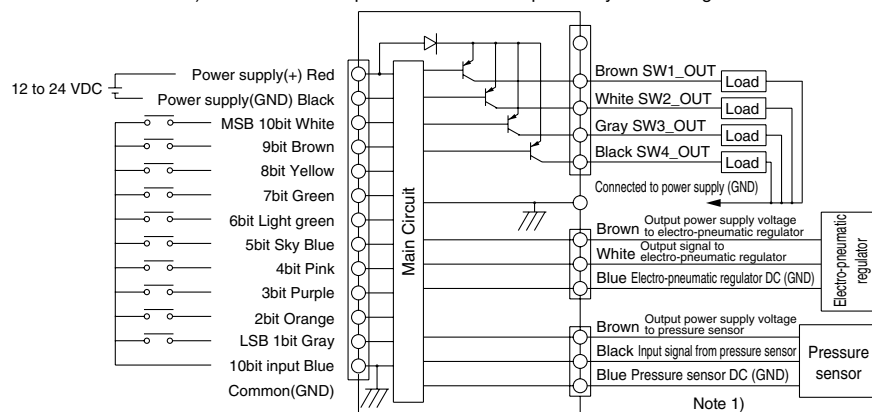

IC□□-1□□ (PNP open collector output type)

Note 1) Connection to the pressure sensor is required only when using the external sensor type.

Series IC

Dimensions

Internal sensor type

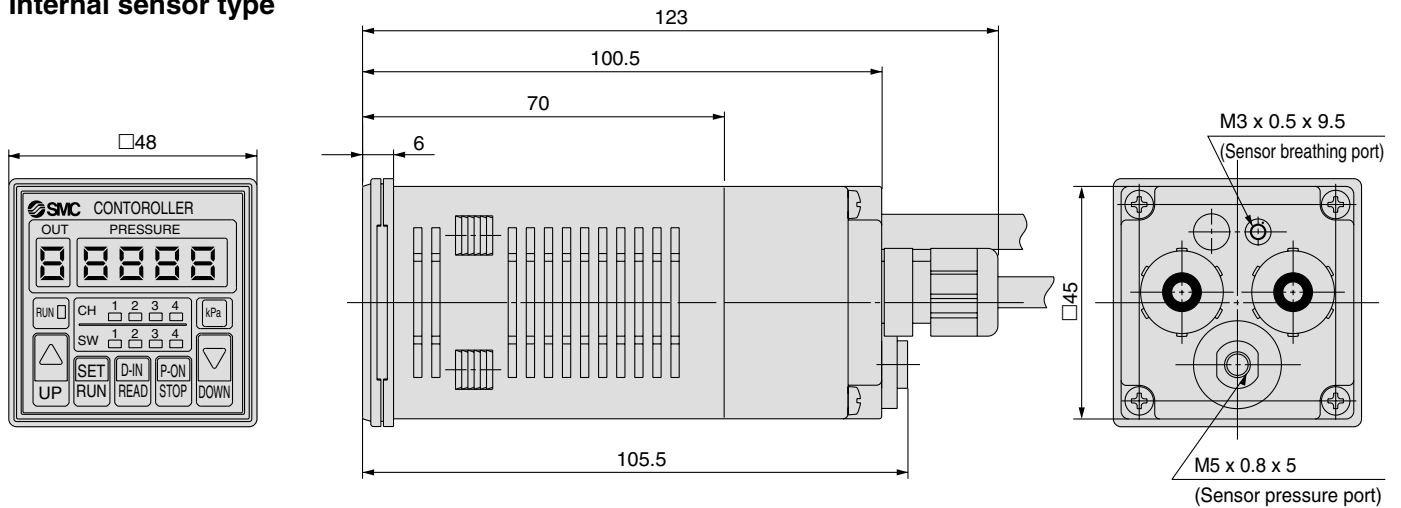

External sensor type

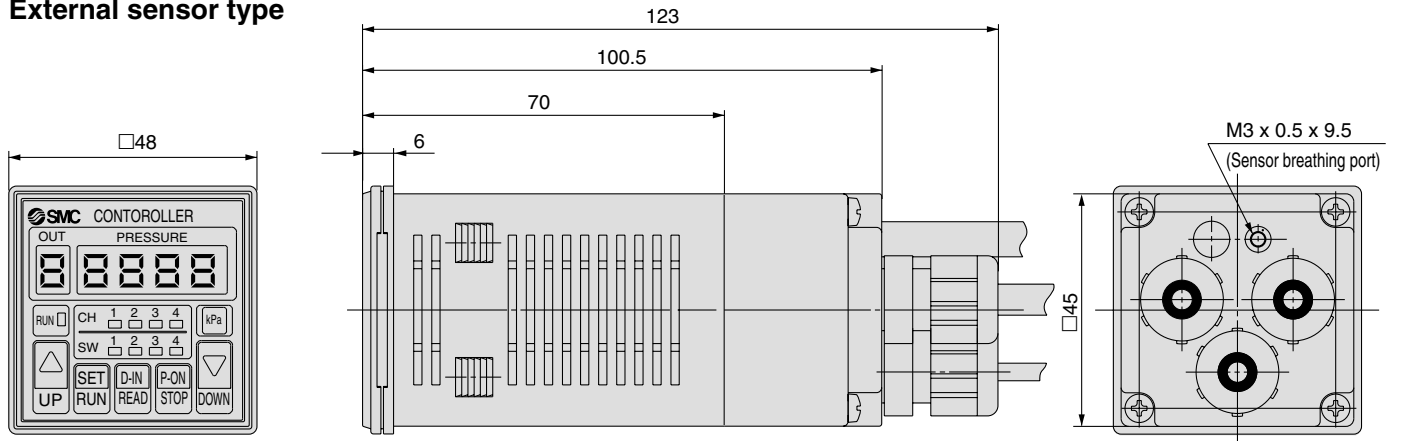

Option

Panel mount adapter

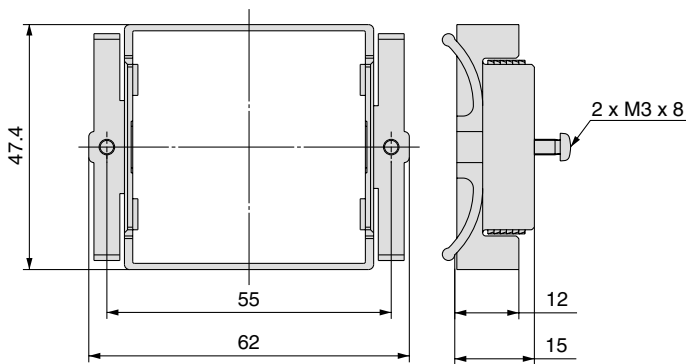

Protective cover

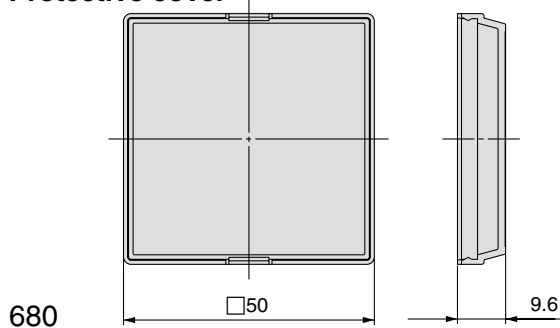

Panel fitting dimension

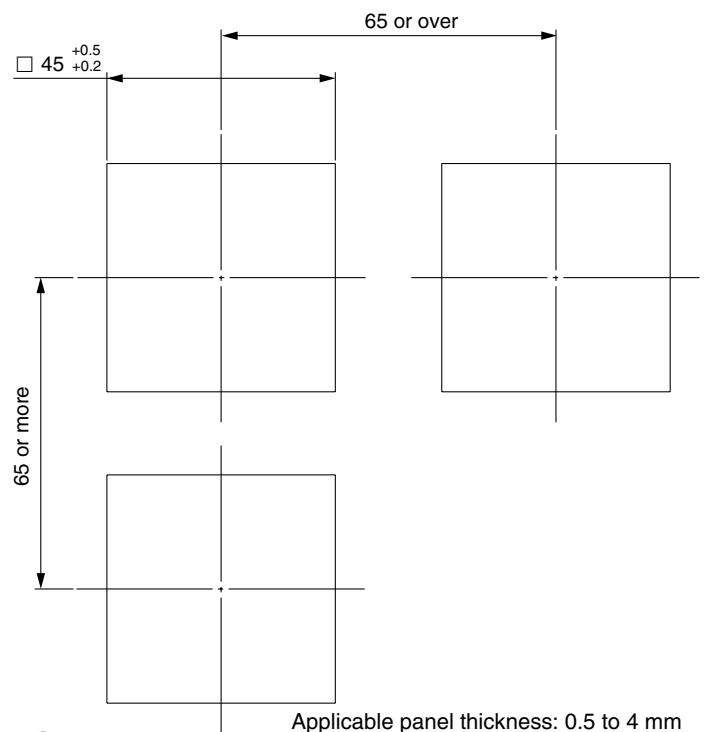



Series IC Specific Product Precautions

Be sure to read before handling.
Refer to front matters 42 and 43 for Safety Precautions.

■ Controller for Electro-pneumatic Regulator

Handling

⚠ Warning

1. Do not drop, bump, or apply excessive impacts (980 m/s²) while handling. Although the body of the sensor may not be damaged, the inside of the sensor could be damaged and lead to a malfunction.
2. The tensile strength of the cord is 20 N. Applying a greater pulling force on it can cause a malfunction. When handling, hold the body of the sensor – do not dangle it from the cord.
3. Do not exceed the screw-in torque of 3.5 N·m when installing piping. Exceeding this value may cause malfunctioning of the sensor.
4. The minimum bending radius of the cable is 50 mm.
5. Do not use pressure sensors with corrosive and/or inflammable gases or liquids.

Operating Environment

⚠ Warning

1. This controller for electro-pneumatic regulator is not rated as explosion proof. Never use it in an atmosphere of corrosive or explosive gas.
2. Only the display unit of the controller for electro-pneumatic pressure regulator has an enclosure equivalent to IP65 rating.

Connection

⚠ Warning

1. Incorrect wiring can damage the switch and cause a malfunction or erroneous switch output. Connections should be done while the power is turned off.
2. Do not attempt to insert or pull the pressure sensor or its connector when the power is on. Switch output may malfunction.
3. Wire separately from power lines and high voltage lines, avoiding wiring in the same conduit with these lines. Malfunctions may occur due to noise from these other lines.
4. If a commercial switching regulator is used, make sure that the F.G. terminal is grounded.

Mounting

⚠ Caution

1. Mounting with panel mount adapter

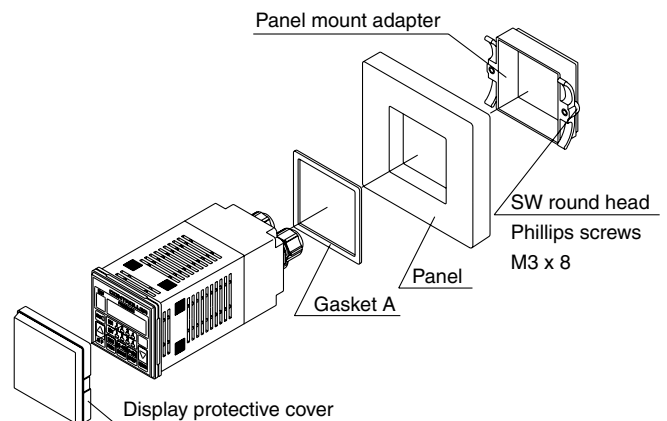

Tighten screws by 1/4 to 1/2 turn after the heads are flush with the panel.

ARJ

AR425
to 935

AMR

ARM

ARP

IR

IRV

VEX1□

SRH

SRP

SRF

ARX20

VCHR

ITV

IC

PVQ

VEF
VEP

VER

VEA

VY2

VBA
VBAT

AP100