

# Clean Gas Filter

## Series SF

### Cartridge Type/Disposable Type

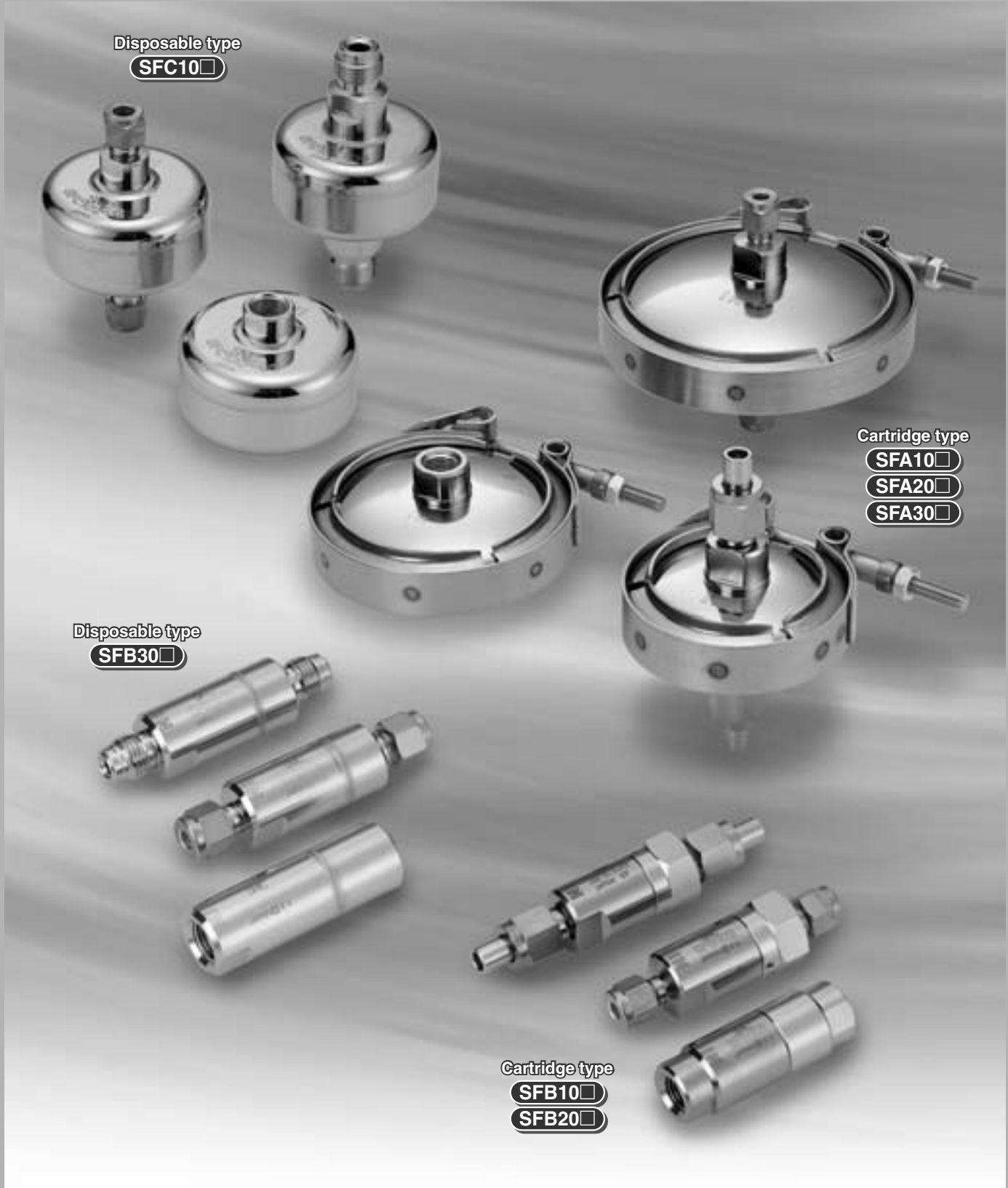

HAA  
HAW

AT

IDF  
IDU

IDFA

IDFB

ID

IDG

AMG

AFF

AM

AMD

AMH

AME

AMF

SF

SFD

LLB

AD

GD

# SMC Clean Gas Filter (Series SF)

## ■ Integrated production in a clean environment

Under a clean environment, cleaning, assembly, inspection and antistatic double packaging processes are done in an integrated production system.

## ■ Quality Control

All clean gas filters (Series SF) are inspected at the time of shipment.

Shipping inspection	
Cartridge type	Disposable type
<ul style="list-style-type: none"> <li>• Purification test</li> <li>• Airtight test</li> </ul>	<ul style="list-style-type: none"> <li>• Purification test</li> <li>• Helium leak test</li> <li>• Pressure holding test</li> </ul>

Assembly environment
<ul style="list-style-type: none"> <li>• Clean room: M5.5 (ISO class 7)*</li> <li>• Clean booth: M3.5 (ISO class 5)*</li> </ul>

\* Fed.std.209E ( ): based on ISO 14644-1

## ■ High precision filtration

0.01  $\mu\text{m}$  filtration (filtering efficiency of 99.99%) is realized with the PTFE membrane cartridge element. (Clean gas strainer: Nominal filtration of 120  $\mu\text{m}$ )

## ■ Can be used under different environments

This filter can be used under different environments with chemical resistant and heat resistant materials (Refer to specifications for each series.).

## Applications and Circuit Examples

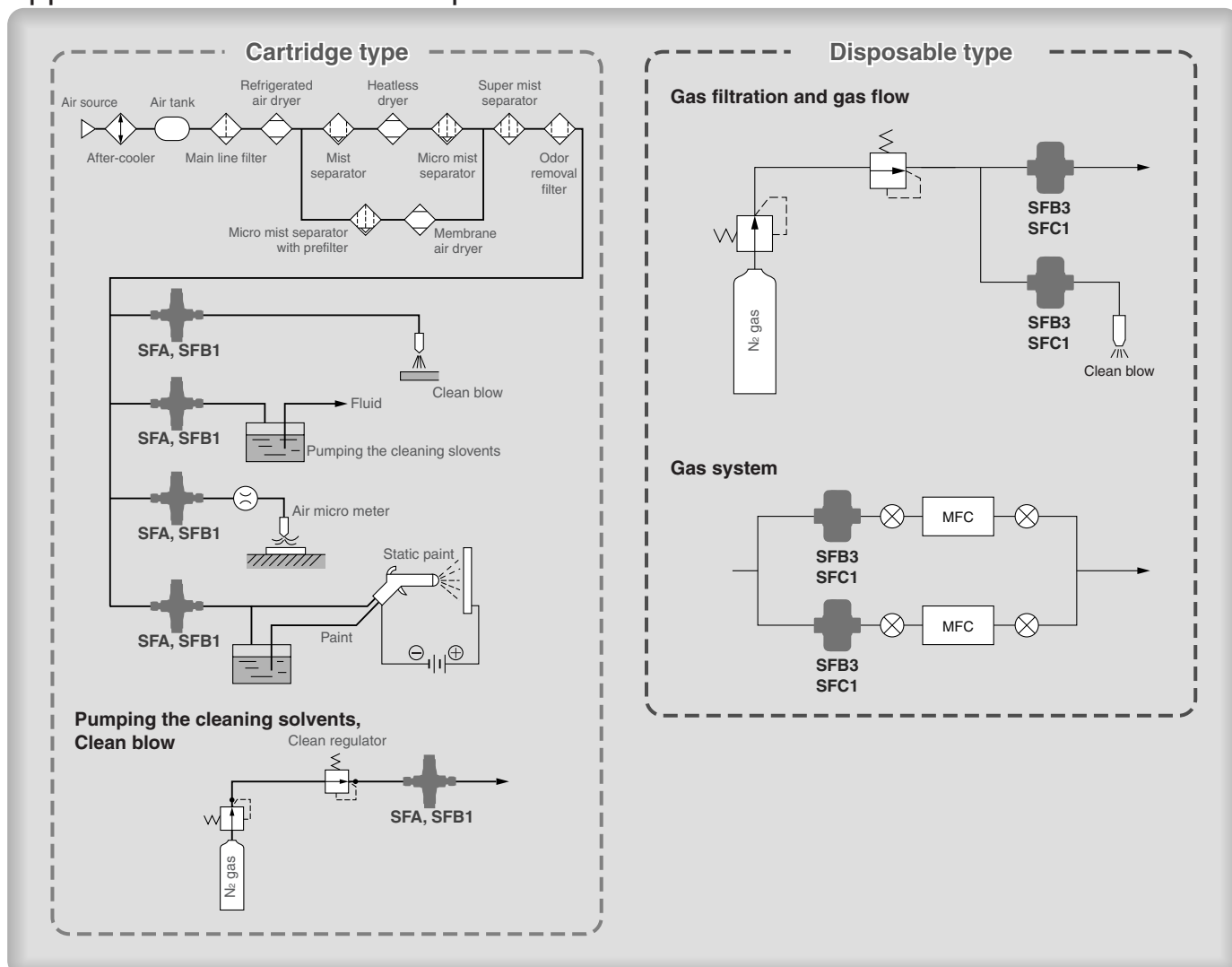

# Variations

	Series	Filtration	Flow rate $l/min$ (ANR) (Inlet pressure is 0.7 MPa, at pressure drop of 0.02 MPa)	Pressure MPa	Temperature °C	Replacement of element	Page
Cartridge type	<b>Disc style</b> 	<b>SFA10</b> □  <b>SFA20</b> □  <b>SFA30</b> □ 0.01 μm (Filtering efficiency 99.99%) (Membrane element)	26	0.99	5 to 80	Replaceable	P. 225
			70				
			140				
	<b>SFB10</b> □  <b>SFB20</b> □ (Strainer)	Nominal <b>120 μm</b> (Sintered metallic element)	45				P. 228
400			P. 229				
Disposable type	<b>SFB30</b> □  <b>SFB30</b> □ (Strainer)	0.01 μm (Filtering efficiency 99.99%) (Membrane element)	45	0.99	5 to 120	Nonreplaceable	P. 232
	<b>SFC10</b> □  <b>SFC10</b> □ (Strainer)		240				0.99
Made to Order		<ul style="list-style-type: none"> <li>Case/Cover material: Aluminum alloy (<b>SFB100</b>)</li> <li>Strainer with other nominal filtration: 1, 2, 5, 10, 20, 40, 70, 100 μm (<b>SFB200</b>)</li> </ul>					P. 238
Specific Product Precautions							P. 239

HAA  
HAW

AT

IDF  
IDU

IDFA

IDFB

ID

IDG

AMG

AFF

AM

AMD

AMH

AME

AMF

SF

SFD

LLB

AD□

GD

# Model Selection

Determine the model by using the following procedures involving the inlet pressure and the maximum flow rate.

Example) Inlet pressure: 0.6 MPa

Maximum flow rate: 200  $\ell$ /min (ANR)

1. Determine intersection A for the inlet pressure and the maximum flow rate by using the maximum flow rate graph.
2. If the obtained intersection A is above the maximum flow rate line, SFC10□ is selected.

Note) Please be sure to select a model with a maximum flow rate line which is above the obtained intersection A.

If the obtained intersection A is below the maximum flow rate line, overflow will occur. This will cause a nonconformance in which the specification will not be satisfied.

## Maximum Flow Rate Lines

### Clean Gas Filter

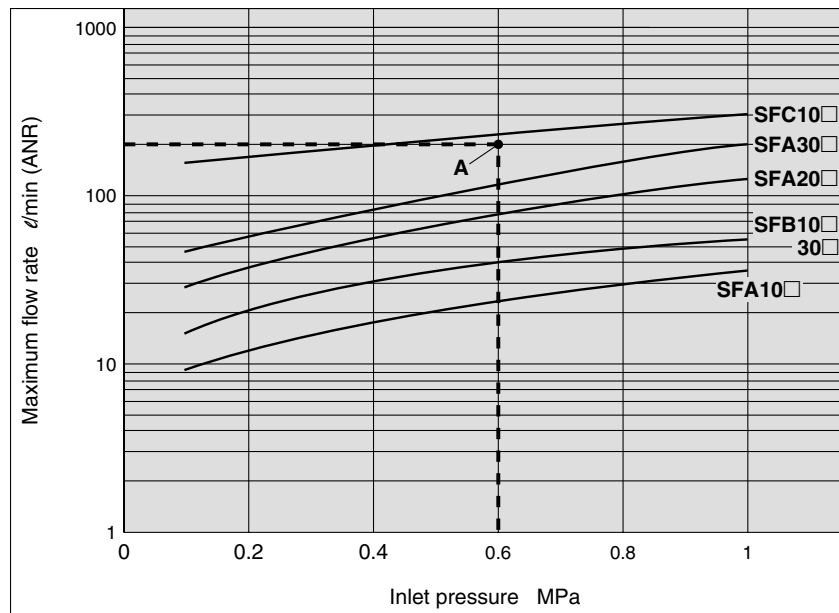

### Clean Gas Strainer

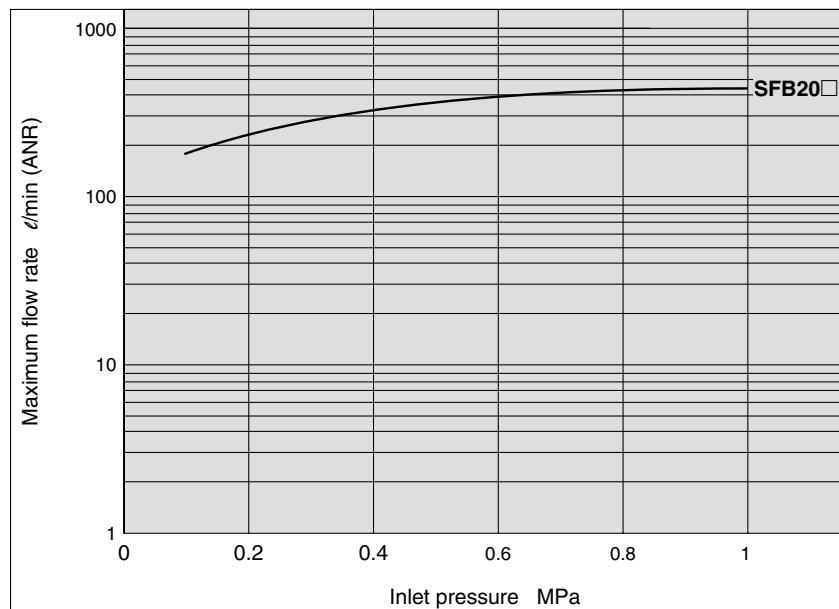

# Clean Gas Filter: Cartridge Type/Disc Style Series **SFA100/200/300**

**Precision filtration for general gases used in the electronic industry, etc.**

Compressed air, Nitrogen, etc.

**PTFE membrane element is made into a cartridge. (Filtration 0.01 μm (Filtering efficiency 99.99%))**

Made into a cartridge by polyester holder and fluorine rubber (FKM) gasket.

**All products are tested at the time of shipment.**

Purification test

Airtight test

**Elements are replaceable.**

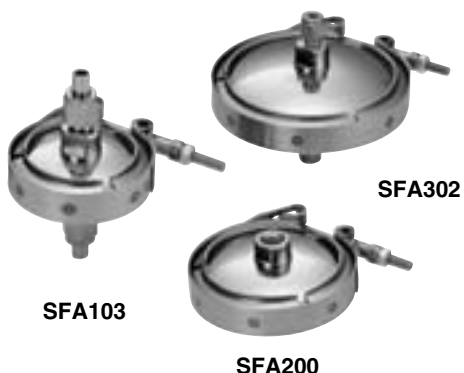

## How to order

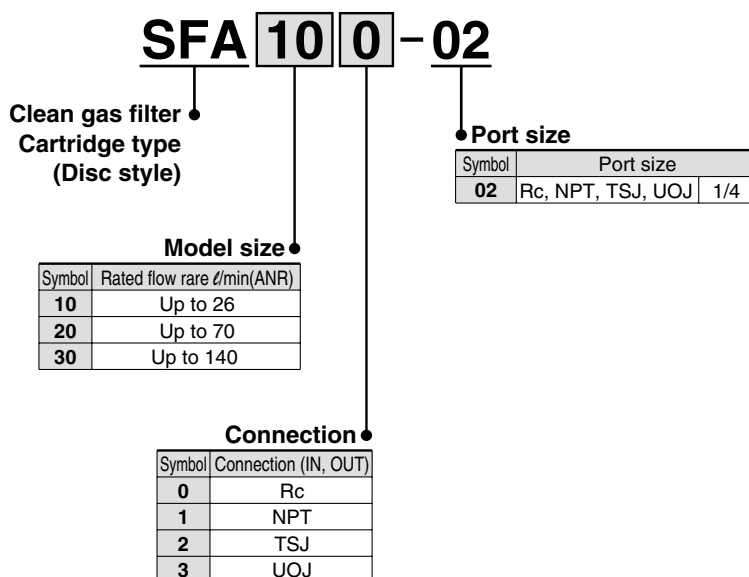

## Model

Model	Rated flow rate ℓ/min (ANR) <sup>Note 1)</sup>	Connection	Filtration area cm <sup>2</sup>	Element part no. <sup>Note 2)</sup>	Mass kg
<b>SFA100-02</b>	26	Rc 1/4 (Female thread)	13.85	ED001S-X10V	0.34
<b>SFA101-02</b>		NPT 1/4 (Female thread)			
<b>SFA200-02</b>	70	Rc 1/4 (Female thread)	33.18	ED101S-X10V	0.44
<b>SFA201-02</b>		NPT 1/4 (Female thread)			
<b>SFA300-02</b>	140	Rc 1/4 (Female thread)	56.75	ED201S-X10V	0.66
<b>SFA301-02</b>		NPT 1/4 (Female thread)			
<b>SFA102-02</b>	26	TSJ 1/4 Tube Swage Joint	13.85	ED001S-X10V	0.38
<b>SFA202-02</b>	70		33.18	ED101S-X10V	0.49
<b>SFA302-02</b>	140		56.75	ED201S-X10V	0.70
<b>SFA103-02</b>	26	UOJ 1/4 Union O-ring Joint	13.85	ED001S-X10V	0.42
<b>SFA203-02</b>	70		33.18	ED101S-X10V	0.53
<b>SFA303-02</b>	140		56.75	ED201S-X10V	0.75

Note 1) Inlet pressure 0.7 MPa, at pressure drop 0.02 MPa

Note 2) Element part numbers include numbers 3 to 7 in the construction figure. (Refer to page 226.)

HAA  
HAW

AT

IDF  
IDU

IDFA

IDFB

ID

IDG

AMG

AFF

AM

AMD

AMH

AME

AMF

SF

SFD

LLB

AD□

GD

# Series SFA100/200/300

## Specifications

<b>Operating fluid</b>		Air, Nitrogen
<b>Operating pressure</b> <small>Note 1)</small>		Max. 0.99 MPa, Vacuum $1.3 \times 10^{-6}$ kPa
<b>Operating temperature</b>		5 to 80°C
<b>Element proof differential pressure</b>		Max. 0.1 MPa
<b>Element reverse differential pressure</b>		Max. 0.05 MPa
<b>Filtration</b> <small>Note 2)</small>		0.01 $\mu\text{m}$ (Filtering efficiency 99.99%)
<b>Purification in the outlet side</b>		Particle with 0.1 $\mu\text{m}$ or larger 0 pcs/6 $\ell$
<b>Main material</b>	<b>Case</b>	Stainless steel 316 (Interior/Exterior: Electrolytic polishing)
	<b>Filter medium</b>	PTFE membrane
	<b>Seal</b>	Fluororubber (FKM)
<b>Packaging</b>		Antistatic sealed double package

Note 1) The maximum operating pressure is 0.99 MPa since this product does not conform to the High Pressure Gas Safety Law.

Note 2) Based on SMC's measuring conditions. (Refer to Technical Data SM-86-009.)

## Construction

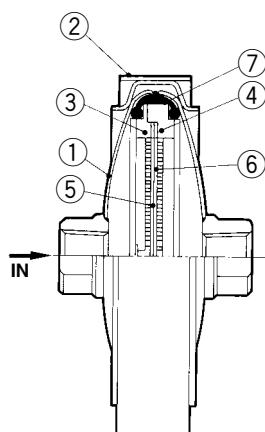

No.	Description	Material	Note
1	Case	Stainless steel 316	Electrolytic polishing (Interior/Exterior)
2	V-clamp	Stainless steel 304	—
3	Holder 1	Polyester	Cartridge element
4	Holder 2		
5	Filter medium	PTFE	
6	Seal	FKM	
7	V-seal		

# Clean Gas Filter: Cartridge Type/Disc Style **Series SFA100/200/300**

**Flow Characteristics** Fluid: Compressed air Inlet temperature: 20°C

## SFA10□

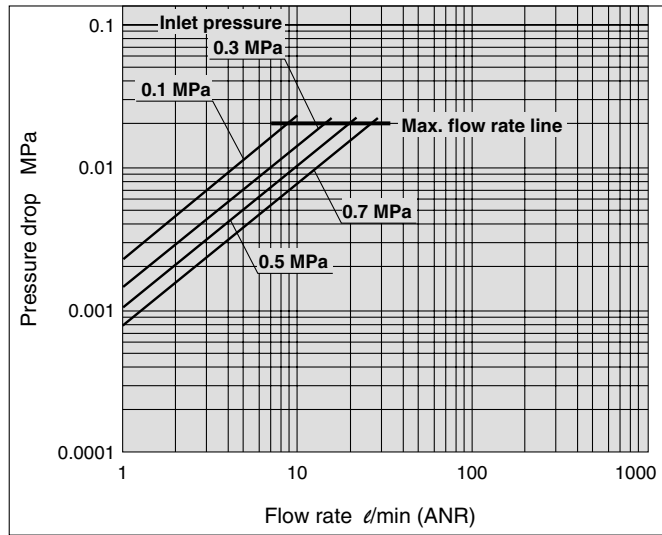

## SFA20□

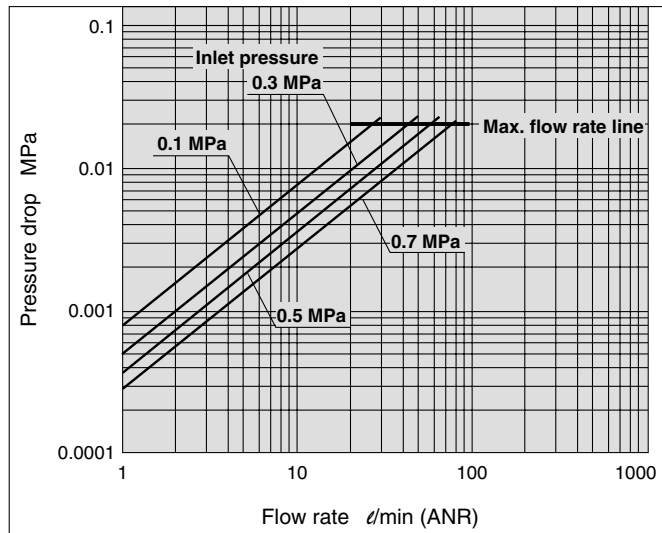

## SFA30□

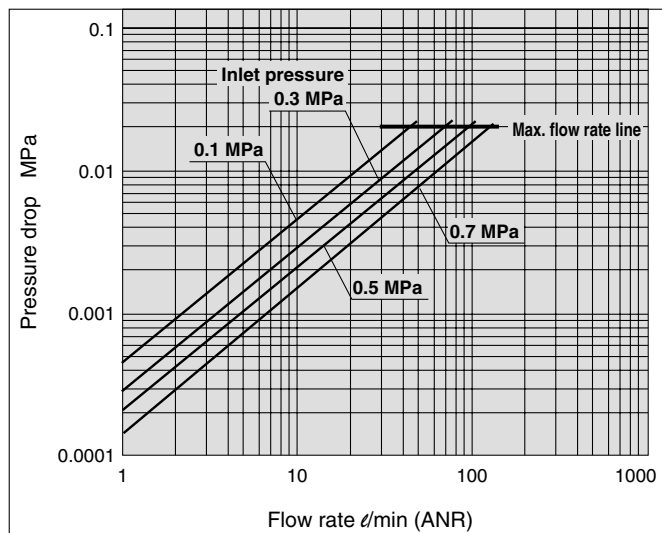

## Dimensions

SFA100/101, SFA200/201, SFA300/301

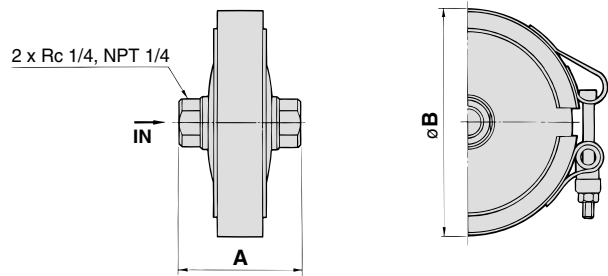

Model	Connection	A	øB
SFA100-02	Rc 1/4	46	76
SFA101-02	NPT 1/4		
SFA200-02	Rc 1/4	51	96
SFA201-02	NPT 1/4		
SFA300-02	Rc 1/4	59	120
SFA301-02	NPT 1/4		

SFA102, SFA202, SFA302

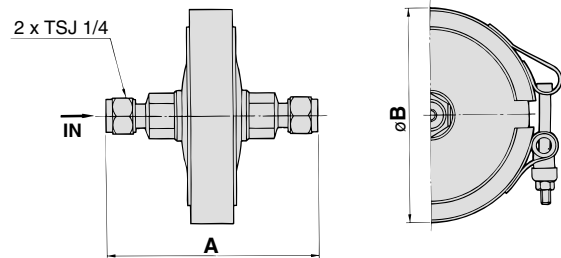

Model	Connection	A	øB
SFA102-02	TSJ 1/4 (Tube Swage Joint)	89	76
SFA202-02		93	96
SFA302-02		101	120

SFA103, SFA203, SFA303

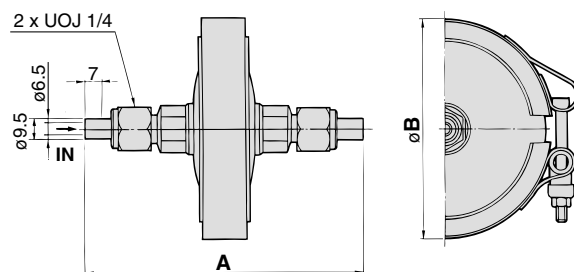

Model	Connection	A	øB
SFA103-02	UOJ 1/4 (Union O-ring Joint)	117	76
SFA203-02		122	96
SFA303-02		130	120

HAA  
HAW

AT

IDF  
IDU

IDFA

IDFB

ID

IDG

AMG

AFF

AM

AMD

AMH

AME

AMF

SF

SFD

LLB

AD□

GD

# Clean Gas Filter: Cartridge Type/Straight Style Series **SFB100**

**Precision filtration for general gases used in the electronic industry, etc.**

Compressed air, Nitrogen, etc.

**PTFE membrane element is made into a cartridge. (Filtration 0.01 μm (Filtering efficiency 99.99%))**

Made into a cartridge by polyester holder and fluorine rubber (FKM) gasket.

**All products are tested at the time of shipment.**

Purification test

Airtight test

**Elements are replaceable.**

**Bracket is included as a standard.**

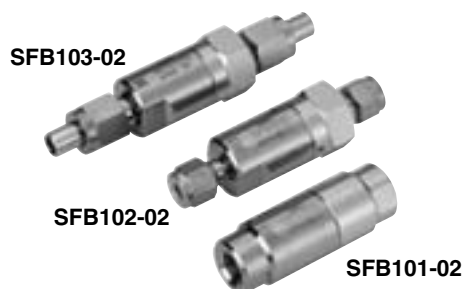

## How to order

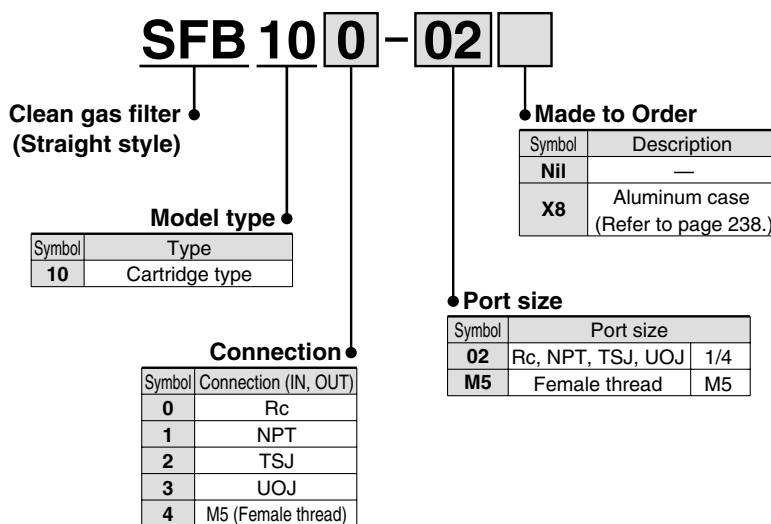

## Specifications

Operating fluid	Air, Nitrogen	
Operating pressure <sup>Note1)</sup>	Max. 0.99 MPa, Vacuum 1.3 x 10 <sup>-6</sup> kPa	
Operating temperature	5 to 80°C	
Element proof differential pressure	Max. 0.5 MPa	
Element reverse differential pressure	Max. 0.07 MPa	
Filtration <sup>Note2)</sup>	0.01 μm (Filtering efficiency 99.99%)	
Purification in the outlet side	Particle with 0.1 μm or larger 0 pcs/6 ℓ	
Main material	Case/Cover	Stainless steel 316 (Interior/Exterior: Electrolytic polishing)
	Filter medium	PTFE membrane
	Seal	Fluororubber (FKM)
Packaging	Antistatic sealed double package	

Note 1) The maximum operating pressure is 0.99 MPa since this product does not conform to the High Pressure Gas Safety Law.

Note 2) Based on SMC's measuring conditions. (Refer to Technical Data SM-86-009.)

## Model

Model	Rated flow rate ℓ/min (ANR) <sup>Note)</sup>	Connection	Filtration area cm <sup>2</sup>	Element part no.	Mass kg
SFB100-02	45	Rc 1/4 (Female thread)	10	ED301S-X10V (Including O-rings)	0.15
SFB101-02		NPT 1/4 (Female thread)			
SFB102-02		TSJ 1/4			
SFB103-02		UOJ 1/4			
SFB104-M5		M5 (Female thread)			

Note) Inlet pressure 0.7 MPa, at pressure drop 0.02 MPa



# Clean Gas Strainer: Cartridge Type/Straight Style Series *SFB200*

## Cartridge made of stainless steel 316 sintered metallic element (Nominal filtration: 120 μm)

Clean gas strainers made of an element (120 μm, stainless steel 316 sintered metal) to protect regulators and vacuum regulators are also available.



## How to order

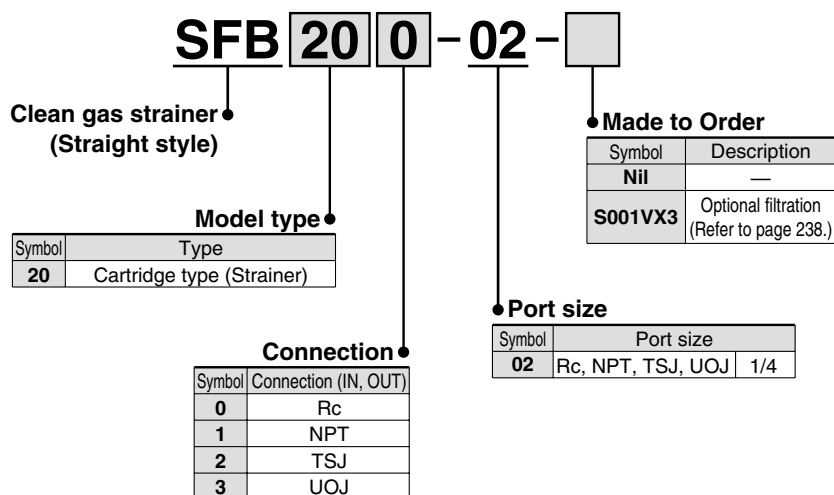

## Specifications

<b>Operating fluid</b>	Air, Nitrogen	
<b>Operating pressure</b>	Max. 0.99 MPa, Vacuum 1.3 x 10 <sup>-6</sup> kPa	
<b>Operating temperature</b> <sup>Note)</sup>	5 to 80°C	
<b>Element proof differential pressure</b>	Max. 1.0 MPa	
<b>Element reverse differential pressure</b>	Max. 1.0 MPa	
<b>Nominal filtration</b>	120 μm	
<b>Main material</b>	<b>Case/Cover</b>	Stainless steel 316 (Interior/Exterior: Electrolytic polishing)
	<b>Seal</b>	Fluororubber (FKM)
	<b>Filter medium</b>	Stainless steel 316 sintered metal
<b>Packaging</b>	Antistatic sealed double package	

## Model

Model	Rated flow rate <i>d</i> /min (ANR) <sup>Note)</sup>	Connection	Filtration area cm <sup>2</sup>	Element part no.	Mass kg
<b>SFB200-02</b>	400	Rc 1/4 (Female thread)	10	ES001S-120V (Including O-rings)	0.16
<b>SFB201-02</b>		NPT 1/4 (Female thread)			
<b>SFB202-02</b>		TSJ 1/4			0.17
<b>SFB203-02</b>		UOJ 1/4			0.20

Note) Inlet pressure 0.7 MPa, at pressure drop 0.02 MPa

HAA  
HAW

AT

IDF  
IDU

IDFA

IDFB

ID

IDG

AMG

AFF

AM

AMD

AMH

AME

AMF

SF

SFD

LLB

AD□

GD

# Series SFB100/200

## Construction

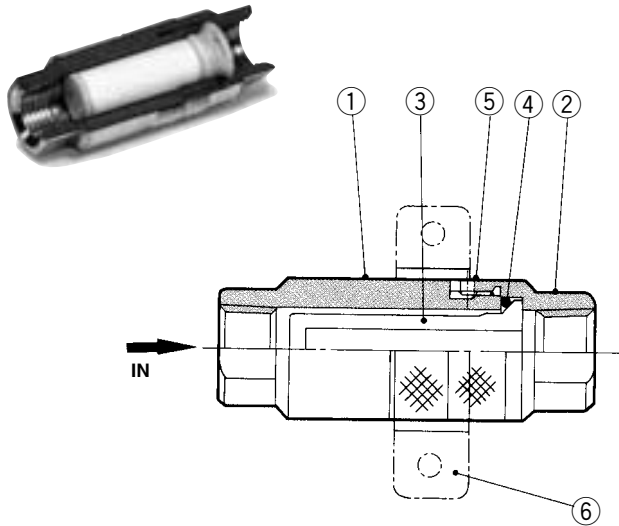

No.	Description	Material	Note
1	Case	Stainless steel 316	Electrolytic polishing (Interior/Exterior)
2	Cover		
3	Clean gas filter	PTFE membrane	For SFB10□
	Clean gas strainer	Stainless steel 316 sintered metal	For SFB20□
4	O-ring	FKM	—
5	Hexagon socket head screw	Stainless steel 304	M3
6	Bracket		—

## Flow Characteristics Fluid: Compressed air Inlet temperature: 20°C

### SFB104-M5

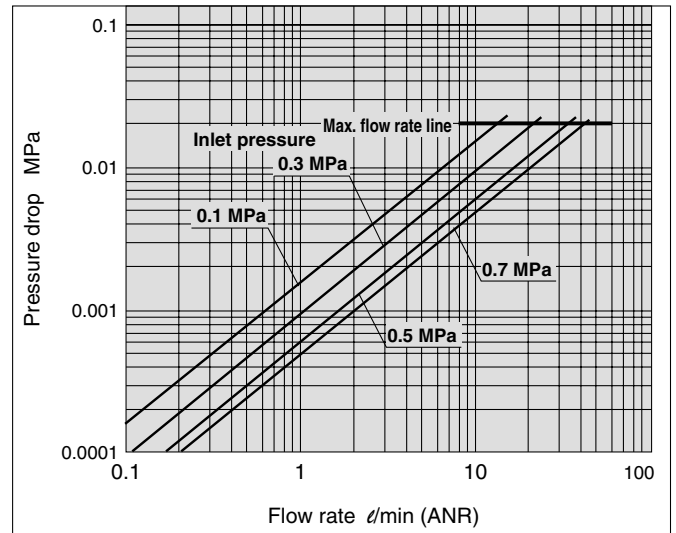

### SFB10□-02

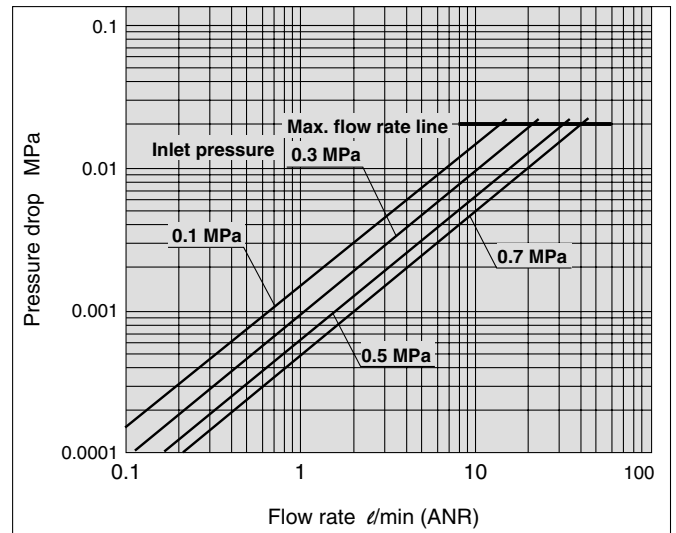

### SFB20□-02

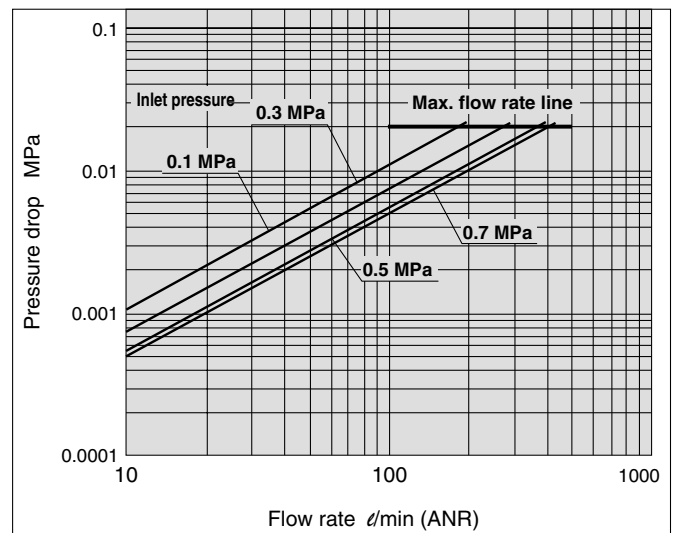

# Clean Gas Filter/Clean Gas Strainer: Cartridge Type/Straight Style **Series SFB100/200**

## Dimensions

**SFB100/200:** Rc 1/4  
**SFB101/201:** NPT 1/4  
**SFB104:** M5

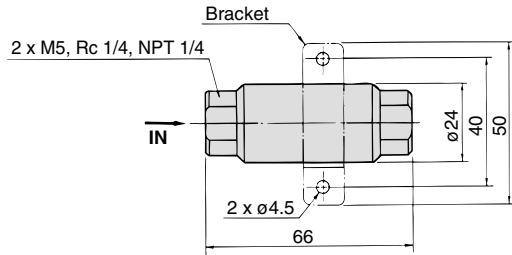

Model	Connection
<b>SFB100-02, 200-02</b>	Rc 1/4
<b>SFB101-02, 201-02</b>	NPT 1/4
<b>SFB104-M5</b>	M5

**SFB102-02, SFB202-02:** TSJ 1/4 (Tube Swage Joint)

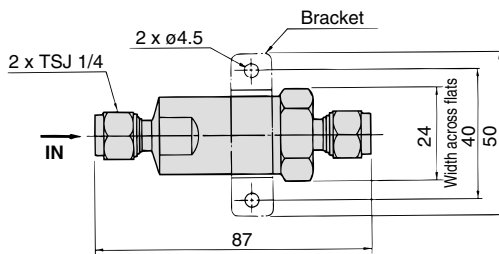

**SFB103-02, SFB203-02:** UOJ 1/4 (Union O-ring Joint)

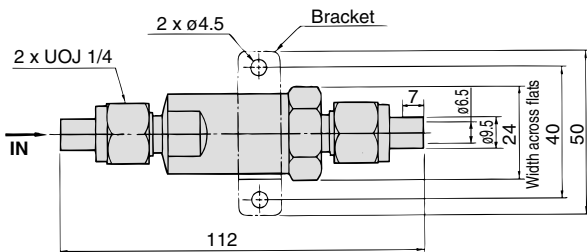

HAA
HAW
AT
IDF
IDU
IDFA
IDFB
ID
IDG
AMG
AFF
AM
AMD
AMH
AME
AMF
SF
SFD
LLB
AD□
GD

# Clean Gas Filter: Disposable Type/Straight Style Series **SFB300**

**Precision filtration for gases used in the semiconductor process**

Compressed air, Nitrogen, etc.

**PTFE membrane with high reliability**

**Filtration 0.01 μm (Filtering efficiency 99.99%)**

**All products are tested at the time of shipment.**

Purification test  
Helium leak test  
Pressure holding test

**Bracket is included as a standard.**



## How to order

**SFB 30 0 - 02**

● Clean gas filter (Straight style)

● Port size

Symbol	Port size
02	Rc, NPT, TSJ, UOJ 1/4

● Model type

Symbol	Type
30	Disposable type (Narrow size)
31	Disposable type (Long size)

● Connection

Symbol	Connection (IN, OUT)
0	Rc
2	TSJ
5	URJ

\* SFB31: Only 5 is selectable.

## Model

Model	Rated flow rate ℓ/min (ANR) <sup>Note)</sup>	Connection	Filtration area cm <sup>2</sup>	Mass kg
SFB300-02	45	Rc 1/4 (Female thread)	10	0.14
SFB302-02		TSJ 1/4		0.15
SFB305-02		URJ 1/4		0.14
SFB315-02		URJ 1/4		0.15

Note) Inlet pressure 0.7 MPa, at pressure drop 0.02 MPa

## Specifications

<b>Operating fluid</b>		Air, Nitrogen
<b>Operating pressure</b> <small>Note 1)</small>		Max. 0.99 MPa, Vacuum $1.3 \times 10^{-6}$ kPa
<b>Operating temperature</b>		5 to 120°C
<b>Element proof differential pressure</b>		Max. 0.5 MPa
<b>Element reverse differential pressure</b>		Max. 0.07 MPa
<b>Filtration</b> <small>Note 2)</small>		0.01 μm (Filtering efficiency 99.99%)
<b>Purification in the outlet side</b>		Particle with 0.1 μm or larger 0 pcs/6 ℓ
<b>Helium leak volume</b>		$4.0 \times 10^{-9}$ Pa·m <sup>3</sup> /sec or less
<b>Main material</b>	<b>Case/Cover</b>	Stainless steel 316 (Interior/Exterior: Electrolytic polishing)
	<b>Filter medium</b>	PTFE membrane
	<b>O-ring</b>	Stainless steel 304

Note 1) The maximum operating pressure is 0.99 MPa since this product does not conform to the High Pressure Gas Safety Law.  
 Note 2) Based on SMC's measuring conditions. (Refer to Technical Data SM-86-009.)

## Construction

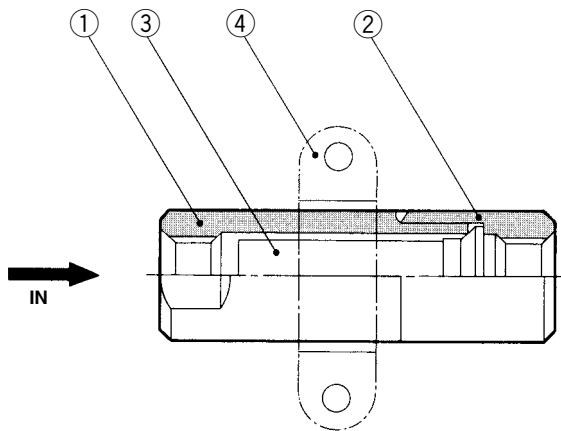

No.	Description	Material	Note
1	<b>Case</b>	Stainless steel 316	Electrolytic polishing (Interior/Exterior)
2	<b>Cover</b>		
3	<b>Element</b>	PTFE membrane	
4	<b>Bracket</b>	Stainless steel 316 sintered metal	

HAA
HAW
AT
IDF
IDU
IDFA
IDFB
ID
IDG
AMG
AFF
AM
AMD
AMH
AME
AMF
<b>SF</b>
SFD
LLB
AD□
GD

# Series SFB300

**Flow Characteristics** Fluid: Compressed air Inlet temperature: 20°C

## SFB30□-02

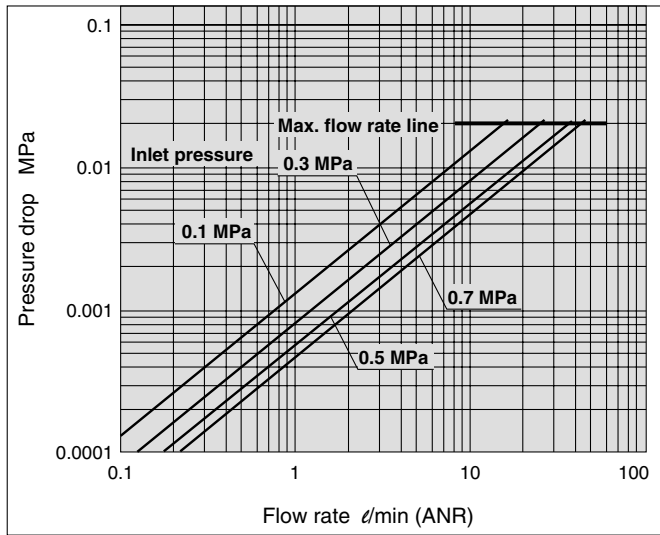

## Dimensions

### SFB300-02: Rc 1/4

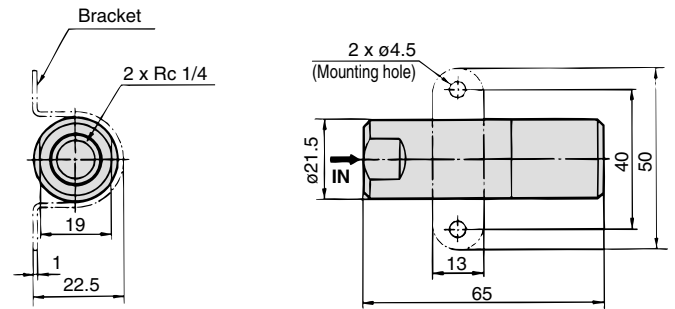

### SFB302-02: TSJ 1/4 (Tube Swage Joint)

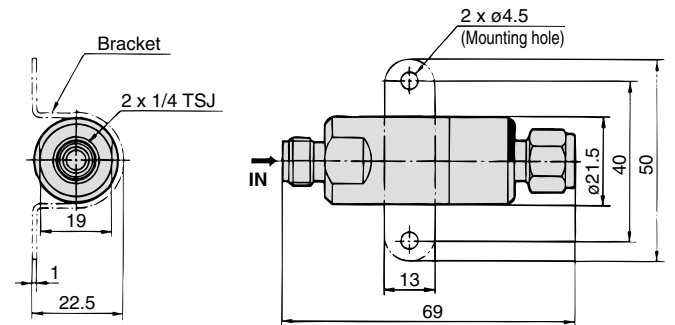

### SFB305-02, SFB315-02: URJ 1/4 (Union Ring Joint)

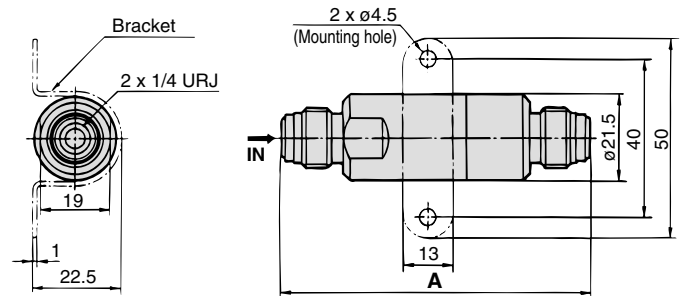

Model	A
SFB305-02	79
SFB315-02	84

# Clean Gas Filter: Disposable Type/Multiple Disc Style Series *SFC100*

**Precision filtration for gases used in the semiconductor process**

Compressed air, Nitrogen, etc.

**PTFE membrane with high reliability**

**Filtration 0.01 μm (Filtering efficiency 99.99%)**

**All products are tested at the time of shipment.**

Purification test  
Helium leak test  
Pressure holding test



## How to order

**SFC 10 0 - 02**

Clean gas filter  
Disposable type  
(Multiple style)

Port size

Symbol	Port size
02	Rc, TSJ, URJ 1/4
03	Rc, TSJ, URJ 3/8

Model type

Symbol	Rated flow rate $l/min$ (ANR)
10	Up to 240

Connection

Symbol	Connection (IN, OUT)
0	Rc
2	TSJ
5	URJ

## Model

Model	Rated flow rate $l/min$ (ANR) <sup>Note)</sup>	Connection	Filtration area $cm^2$	Mass kg
SFC100-02	240	Rc 1/4 (Female thread)	300	0.35
SFC100-03		Rc 3/8 (Female thread)		0.36
SFC102-02		TSJ 1/4		0.40
SFC102-03		TSJ 3/8		0.41
SFC105-02		URJ 1/4		0.44
SFC105-03		URJ 3/8		0.49

Note) Inlet pressure 0.7 MPa, at pressure drop 0.02 MPa

HAA  
HAW

AT

IDF  
IDU

IDFA

IDFB

ID

IDG

AMG

AFF

AM

AMD

AMH

AME

AMF

SF

SFD

LLB

AD□

GD

# Series SFC100

## Specifications

<b>Operating fluid</b>	Air, Nitrogen	
<b>Operating pressure</b> <small>Note 1)</small>	Max. 0.99 MPa, Vacuum $1.3 \times 10^{-6}$ kPa	
<b>Operating temperature</b>	5 to 120°C	
<b>Element proof differential pressure</b>	Max. 0.42 MPa	
<b>Element reverse differential pressure</b>	Max. 0.07 MPa	
<b>Filtration</b> <small>Note 2)</small>	0.01 $\mu\text{m}$ (Filtering efficiency 99.99%)	
<b>Purification in the outlet side</b>	Particle with 0.1 $\mu\text{m}$ or larger 0 pcs/6 $\ell$	
<b>Helium leak volume</b>	$4.0 \times 10^{-9}$ Pa·m <sup>3</sup> /sec or less	
<b>Main material</b>	<b>Case/Cover</b>	Stainless steel 316 (Interior/Exterior: Electrolytic polishing)
	<b>Filter medium</b>	PTFE membrane
	<b>O-ring</b>	PTFE

Note 1) The maximum operating pressure is 0.99 MPa since this product does not conform to the High Pressure Gas Safety Law.

Note 2) Based on SMC's measuring conditions. (Refer to Technical Data SM-86-009.)

## Construction

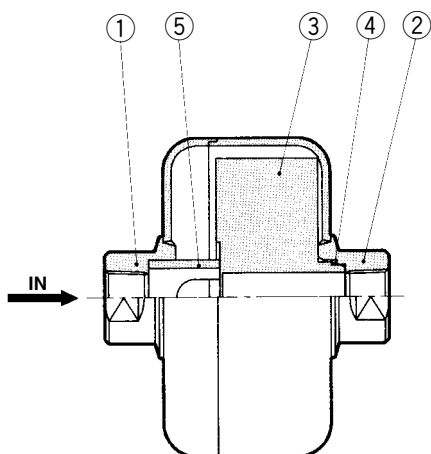

No.	Description	Material	Note
1	Case 1	Stainless steel 316	Electrolytic polishing (Interior/Exterior)
2	Case 2		
3	Element	PTFE, PVDF	
4	O-ring	PTFE	
5	Spacer	PVDF	



# Clean Gas Filter: Disposable Type/Multiple Disc Style **Series SFC100**

**Flow Characteristics** Fluid: Compressed air Inlet temperature: 20°C

## SFC10□

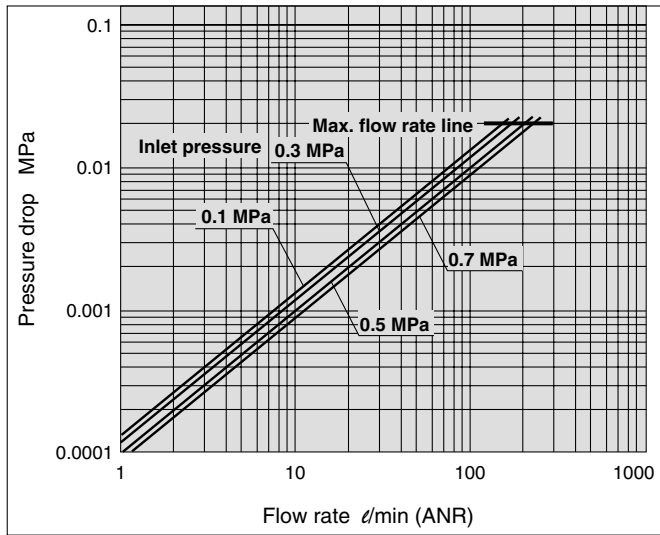

## Dimensions

**SFC100-02:** Rc 1/4

**SFC100-03:** Rc 3/8

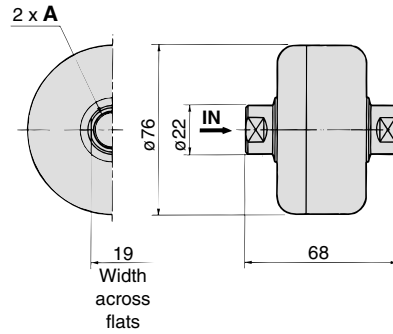

Model	A
SFC100-02	Rc 1/4
SFC100-03	Rc 3/8

**SFC102-02:** TSJ 1/4 (Tube Swage Joint)

**SFC102-03:** TSJ 3/8 (Tube Swage Joint)

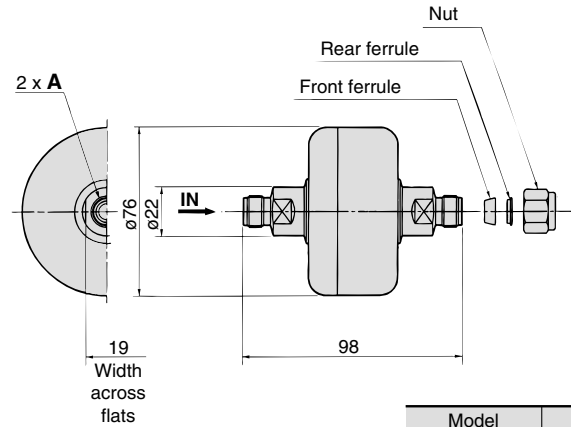

Model	A
SFC102-02	TSJ 1/4
SFC102-03	TSJ 3/8

**SFC105-02:** URJ 1/4 (Union Ring Joint)

**SFC105-03:** URJ 3/8 (Union Ring Joint)

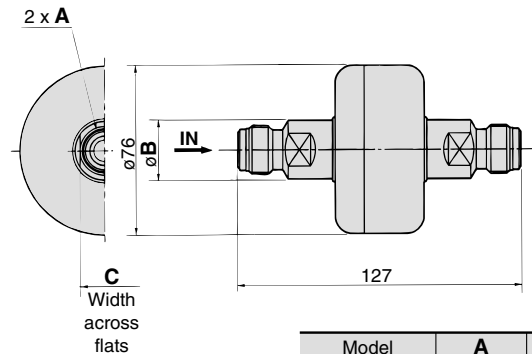

Model	A	B	C
SFC105-02	URJ 1/4	22	19
SFC105-03	URJ 3/8	26.5	22

HAA  
HAW

AT

IDF  
IDU

IDFA

IDFB

ID

IDG

AMG

AFF

AM

AMD

AMH

AME

AMF

SF

SFD

LLB

AD□

GD



Contact us for detailed dimensions, specifications and delivery.

**Case/Cover material: Aluminum alloy**

**Part No.: SFB100-02X8**

## Specifications

Operating fluid	Air	
Operating pressure	Max. 0.99 MPa	
Max. operating temperature	80°C	
Element proof differential pressure	Max. 0.5 MPa	
Element reverse differential pressure	Max. 0.07 MPa	
Filtration <sup>Note)</sup>	0.01 μm (Filtering efficiency 99.99%)	
Connection	Rc 1/4	
Filtration area	10 cm <sup>2</sup>	
Element part no.	ED301S-X10V	
Mass	0.06 kg	
Main material	Case/Cover	A2017 (Clear anodized)
	Seal	Fluororubber (FKM)
	Element	PTFE membrane

Dimensions are identical to the standard models. For details, refer to page 231.  
 Note) Based on SMC's measuring conditions. (Refer to Technical Data SM-86-009.)

**Strainer with other filtration (1,2,5,10,20,40,70,100 μm)**

The filtration other than the standard filtration accuracy, 120 μm, is available with the clean gas strainer.

**Part No.: SFB200-02-S** 002 **VX3**

### Nominal filtration

Symbol	Nominal filtration μm
001	1
002	2
005	5
010	10
020	20
040	40
070	70
100	100

Specifications and dimensions are identical to the standard models. For details, refer to page 231.

## Element Part No.

Nominal filtration (μm)	Part no.	Note
1	ES001S-001VX0	O-ring
2	ES001S-002VX0	
5	ES001S-005VX0	
10	ES001S-010VX0	
20	ES001S-020VX0	
40	ES001S-040VX0	
70	ES001S-070VX0	
100	ES001S-100VX0	



# Series SF□

## Specific Product Precautions 1

Be sure to read before handling.

Refer to front matters 42 and 43 for Safety Instructions and pages 6 to 8 for Air Preparation Equipment Precautions.

### Selection

#### ⚠ Warning

##### 1. Confirm the specifications.

This product is designed for only general gases such as compressed air or Nitrogen.

Do not use this product with special gases, pressure or temperature beyond the specifications. Otherwise, they could cause damage to the product.

(Refer to the specifications.)

### Mounting

#### ⚠ Warning

##### 1. Instruction manual

Mount the product after reading and understanding the instruction manual. Keep it in a location where it can easily be found.

##### 2. Provide enough space for maintenance.

Provide space for maintenance because the IN/OUT pipings have to be removed when the elements are replaced.

##### 3. Follow the piping instructions on the back of pages 240 and 241 when a screw is tightened.

### Operating Environment

#### ⚠ Warning

##### 1. Do not use the product in a place where corrosive gas, chemicals, brine, water and/or water steam are present or can splash on it.

##### 2. Insulate the product if it is used under direct sunlight.

##### 3. Avoid using the product in a place where vibration or impact can occur.

##### 4. Do not use the product in the vicinity of a heat source or under radiant heat.

### Maintenance

#### ⚠ Warning

##### 1. Follow the maintenance procedures in the instruction manual. If handled incorrectly equipment or device can be damaged or cause a malfunction.

##### 2. Maintenance

Product specification must be observed, because mishandling compressed air and/or Nitrogen can cause a dangerous situation. Maintenance such as replacing elements has to be performed by a well-experienced and knowledgeable person.

##### 3. Pre-maintenance inspection

When removing the product, turn off the electrical power, and be sure to shut off the supply pressure and exhaust the compressed air in the system. Proceed only after confirming that all pressure has been released to the atmosphere.

### Maintenance

#### ⚠ Warning

##### 4. Post maintenance inspection

After installation or repair, perform an appropriate function and leakage test.

##### 5. Modification is prohibited.

Do not disassemble or modify the product.

### Caution on Design

#### ⚠ Caution

##### 1. If the pressure difference (pressure drop) between the inlet and the outlet exceeds 0.1 MPa, it can cause damage to the product.

##### 2. Do not install the product in a place where it can be affected by a pulsation of over 0.1 MPa.

##### 3. Use caution regarding the particles that may be emitted from the outlet side of a pneumatic equipment.

Installation of a pneumatic equipment on the outlet side of the SF□ series can deteriorate the cleanliness because a particle will be generated from the equipment. In the case of installing the pneumatic equipment in the outlet side of the SF□ series, dusts can be generated from the equipment, and the degree of cleanliness can be deteriorated.

The mounting position of the pneumatic equipment needs to be considered depending on the degree of cleanliness of a required operating fluid.

##### 4. Design the system to prevent reverse pressure and reverse flow.

Reverse pressure and reverse flow can damage the element.

##### 5. Design that the piping load should not be applied on the product body.

Mount a bracket for the piping and the other connecting equipment so that the piping load is not applied to the product body.

##### 6. Generally, the following pollutant particles are contained in compressed air, although the degree of cleanliness of the compressed air is different depending on the compressor type and specification.

[Pollutant particle substances contained in the compressed air]

- Moisture (drainage)
- Dusts and particles which are in the surrounding air
- Deteriorated oil which is discharged from the compressor
- Solid foreign matter such as rust and/or oil in the piping

1) The SF□ series is not compatible with compressed air which contains fluids such as water and/or oil.

2) Install a dryer (IDF, IDG, ID series), mist separator (AM series), micro mist separator (AMD series), super mist separator (AME series), or odor removal filter (AMF series), etc., for the source of the air for the SF□ series.

HAA  
HAW

AT

IDF  
IDU

IDFA

IDFB

ID

IDG

AMG

AFF

AM

AMD

AMH

AME

AMF

SF

SFD

LLB

AD□

GD



# Series SF □

## Specific Product Precautions 2

Be sure to read before handling.

Refer to front matters 42 and 43 for Safety Instructions and pages 6 to 8 for Air Preparation Equipment Precautions.

### Selection

#### ⚠ Warning

1. Thoroughly and carefully confirm the purpose of use, required specifications and operating conditions (fluid, pressure, flow rate and environment) then select a model within the specifications.
2. Contact us beforehand when the product will be used in applications such as a caisson shield, and breathing and/or medical treatment that affects the human body directly or indirectly.
3. Determine the product by the maximum consumption flow rate.  
When using compressed air for an air blow application, calculate the maximum volume of air that will be consumed before selecting the SF □ series product size. (Using a product which exceeds the maximum air flow and running excessive compressed air can cause the cleanliness of the compressed air to deteriorate and/or its element to be damaged.)
4. Set the air flow capacity with an initial pressure drop of 0.02 MPa or less.  
If the initial pressure drop is set to be high, its service life will be shorten due to clogging.

### Piping

#### ⚠ Caution

1. Unpacking the sealed package  
Since the filter is sealed in an antistatic double bag, the inner package should be unpacked in a clean atmosphere (such as a clean room).
2. Confirm that there is enough space for maintenance before installing and piping this product.
3. Apply a wrench to 2 chamfered flats on the IN side or the OUT side to prevent the housing from rotating.
4. Confirm the IN and the OUT before piping. The product should not be used with the wrong connection.
5. Wrapping of pipe tape  
When screwing together pipes and fittings, etc., confirm that chips from the pipe threads and sealing material do not enter the piping.  
Also, when pipe tape is used, leave 1.5 to 2 thread ridges exposed at the end of the threads.
6. Connection
  - 1) Rc and NPT connection  
Confirm that chips from the pipe threads and sealing material do not enter the piping.  
Also, when pipe tape is used, leave 1.5 to 2 thread ridges exposed at the end of the threads.

### Piping

#### ⚠ Caution

##### 2) TSJ connection

The TSJ fitting is a kind of a self-align fittings. Set it as shown in the figure.

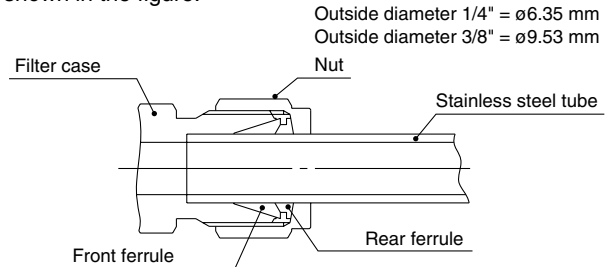

Regarding the TSJ fittings, after tightening the nut by hand, add another 1 1/4 to 1 1/2 turns with a wrench to seal the fitting. In case the fitting is re-installed after filter replacement, first tighten the nut by hand and add another 1/4 to 1/2 turns for sealing. Use the following parts as piping and fittings.

- Piping
    - Outside diameter 1/4" = ø6.35 mm  
Stainless steel pipe
    - or
    - Outside diameter 3/8" = ø9.53 mm  
Stainless steel pipe
  - Nut
  - Front ferrule
  - Rear ferrule
- } Attached to product (2 pcs each)

In the event of replacing the body, a space (20 mm or longer) for extending the stainless steel tubes from the IN and OUT side will be required.

When using similar fittings of other brands, be sure to conduct a helium leak test to confirm there is no leakage before using.

##### 3) UOJ fittings

The UOJ fitting is a union type fitting using a O-ring seal. Install it as illustrated below.

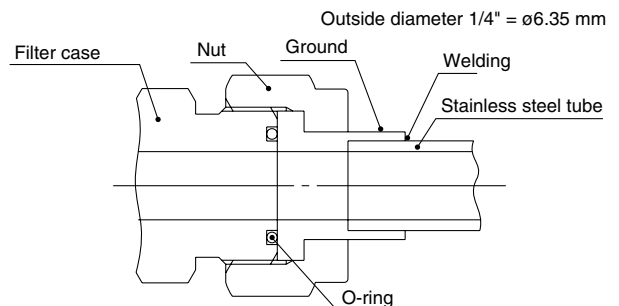

Weld the ground and piping when the fitting is used. At the time of welding, supply inert gas such as Nitrogen to the piping to prevent the formation of an oxide film. Also, remove the oxide film on the external surface through electrolytic polishing or acid cleaning.

After tightening the nut by hand, add another 1/8 turn with a wrench to seal the fitting. Use the following parts for piping and fittings.

- Piping
    - Outside diameter 1/4" = ø6.35 mm  
Stainless steel pipe
  - Nut
  - Ground
  - O-ring
- } Attached to product (2 pcs each)



# Series SF □

## Specific Product Precautions 3

Be sure to read before handling.

Refer to front matters 42 and 43 for Safety Instructions and pages 6 to 8 for Air Preparation Equipment Precautions.

### Piping

#### ⚠ Caution

##### 4) URJ fittings

The URJ fitting is a union type fitting using a metal gasket. Install it as illustrated below.

Outside diameter 1/4" = ø6.35 mm  
Outside diameter 3/8" = ø9.53 mm

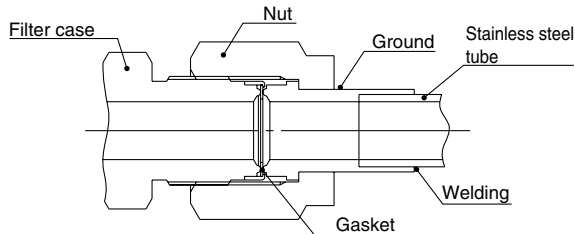

Weld the ground and piping when the fitting is used. At the time of welding, supply inert gas such as Nitrogen to the piping to prevent the formation of an oxide film. Also, remove the oxide film on the external surface through electrolytic polishing or acid cleaning.

After tightening the nut by hand, add another 1/8 turn with a wrench to seal the fitting. Use the following parts for piping and fittings.

<1/4">

- Nut VCR® fittings by Cajon Company  
VCR female nut  
(SS-4-VCR-1)
- Ground VCR® fittings by Cajon Company  
VCR female ground  
(SS-4-VCR-3)
- Gasket VCR® fittings by Cajon Company  
VCR gasket retainer assembly  
(SS-4-VCR-2-GR)

<3/8">

- Piping O.D. 3/8" = ø9.53 mm  
Stainless steel pipe
- Nut VCR® fittings by Cajon Company  
VCR female nut  
(SS-8-VCR-1)
- Ground VCR® fittings by Cajon Company  
VCR female ground  
(SS-8-VCR-3)
- Gasket VCR® fittings by Cajon Company  
VCR gasket retainer assembly  
(SS-8-VCR-2-GR)

Be sure to conduct a helium leak test before using similar fittings from other companies.

Note) VCR® is a registered trademark of Cajon Company

### Piping

#### ⚠ Caution

##### 7. Line flushing

Flush the piping line when the filter is used for the first time or has been replaced. In the event of connecting such as piping, flush (air blow) when using this product for the first time or replacing its elements in order to reduce the affect of the dust generated from the connection, etc.

Flushing the line is also required to eliminate contamination resulting from the piping line installation. Therefore, be sure to flush the line before actually running the system.

When general gases (excluding toxic, corrosive and flammable gases) are used after mounting the filter, sufficiently flush the line with a dry inert gas such as Nitrogen gas. This should be followed by a helium leak test on the fittings before actually running the product.

##### 8. Filter replacement (or element replacement)

Release the gas from the piping to reduce the internal pressure to 0.

Also, when Nitrogen gas is used, replace it with dry Nitrogen gas by purging it in advance.

Replace the filter (or cartridge element) when a differential pressure of 0.1 MPa (pressure drop) between IN and OUT is reached and/or when 1 year has elapsed.

##### 9. Filter replacement should be performed according to the instruction manual to maintain the filter performance and safety.

The instruction manual is contained in the replacement element. However, if the manual is lost, another one can be requested by inquiring to our company.

### Operating Fluid

#### ⚠ Warning

##### 1. Do not use the clean gas filter with fluids other than inert gas such as compressed air and Nitrogen gas.

Using this product with fluids other than inert gas such as compressed air and Nitrogen gas can cause damage and leaks in the seals and O-rings, depending on the operating fluid.

Confirm the seal material in the specifications and the compatibility with the operating fluid.

Model Series SFA  
Series SFB10, 20

Model Series SFB30  
Series SFC

HAA  
HAW

AT

IDF  
IDU

IDFA

IDFB

ID

IDG

AMG

AFF

AM

AMD

AMH

AME

AMF

SF

SFD

LLB

AD □

GD



Series SF □

## Specific Product Precautions 4

Be sure to read before handling.

Refer to front matters 42 and 43 for Safety Instructions and pages 6 to 8 for Air Preparation Equipment Precautions.

### Operating Environment

#### Caution

- 1. When the product is used for blowing, use caution to prevent the work from being damaged by entrained air from the surrounding area.**

When the compressed air is used for air blow, the exhausted air from the blow nozzle may have taken in airborne foreign matter (such as solid particle, fluid particle) from the surround air. The foreign matter will be sprayed on the work, and the airborne foreign matter may adhere to it.

Therefore, use caution for the surrounding environment.

### Maintenance

- 1. When the element comes to the end of its life, immediately replace it with a new filter or replacement element (cartridge type).**

#### **2. Service life of element**

The service life of the element ends when either of the following two conditions occurs.

- 1) After 1 year of usage has elapsed.
- 2) When the pressure drop reaches 0.1 MPa even though the operating period has been less than 1 year.

#### **3. Unpacking the sealed package**

Since the filter, as well as the cartridge element (cartridge type) are sealed in an antistatic double bag, the inner package should be unpacked in a clean atmosphere (such as a clean room).