

Slide Unit

Series CX2/CXWM/CXWL

Slide Bearing/CX2:ø10, ø15, ø25 CXWM:ø10, ø16, ø20, ø25, ø32

Ball Bushing Bearing/CXWL:ø10, ø16, ø20, ø25, ø32

Provided with shock absorbers to absorb impact and noise.

The slide unit can absorb energy in a wide range, in high speed, low-load applications to low speed, high-load applications, without requiring adjustments.

Ensures high positional accuracy.

A high level of positional accuracy can be attained because the two parallel piston rods prevent the rods from rotating, and the workpiece mounting surface and the parallelism of the piston rods are made highly precise.

Auto switches can be installed.

Smooth operation and high thrust.

Mountable on the housing or on the plate.

The slide unit can be mounted on the housing or on the plate, depending on the application. It can also be bolted from the bottom or from the top. The piping can be fitted to the port in any of the three positions, according to how the unit is mounted.

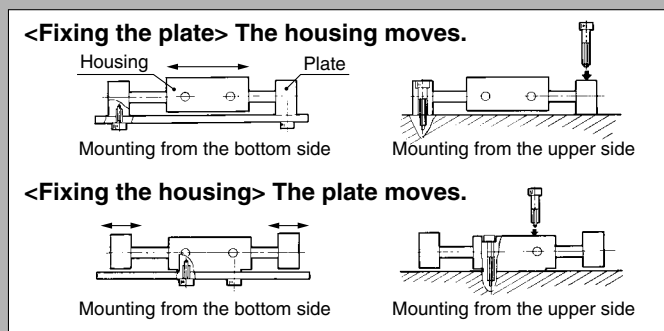

Series Variations

| Slide unit | Bearing type | Model | Bore size | Stroke (mm) | | | | | | | Accessory | Auto switch mounting | Page | | | |
|------------|----------------------|--|---|-------------|-----|----|-----|-----|-----|-----|-----------|----------------------|------|-----|-----|-----|
| | | | | 25 | 50 | 75 | 100 | 125 | 150 | 175 | | | | 200 | | |
| Slide unit | Slide bearing | Series CX2 □ Double rod type (Basic type, compact) | ø10 | ● | ● | ● | ● | ● | ● | ● | ● | ● | (1) | 464 | | |
| | | | ø15 | ● | ● | ● | ● | ● | ● | ● | ● | ● | ● | | ● | |
| | | | ø25 | ● | ● | ● | ● | ● | ● | ● | ● | ● | ● | | ● | |
| | | Ball bushing bearing | Series CXWM Built-in shock absorber type | ø10 | (2) | ● | ● | ● | ● | ● | ● | ● | ● | ● | (1) | 473 |
| | | | | ø16 | (2) | ● | ● | ● | ● | ● | ● | ● | ● | ● | ● | |
| | | | | ø20 | (3) | ● | ● | ● | ● | ● | ● | ● | ● | ● | ● | |
| | ø25 | | | (2) | ● | ● | ● | ● | ● | ● | ● | ● | ● | ● | | |
| | ø32 | | | (3) | (3) | ● | ● | ● | ● | ● | ● | ● | ● | ● | | |
| | ø32 | | | (3) | ● | ● | ● | ● | ● | ● | ● | ● | ● | ● | | |
| | Ball bushing bearing | Series CXWL Built-in shock absorber type | ø10 | ● | ● | ● | ● | ● | ● | ● | ● | ● | ● | (1) | 499 | |
| | | | ø16 | ● | ● | ● | ● | ● | ● | ● | ● | ● | ● | ● | | |
| | | | ø20 | ● | ● | ● | ● | ● | ● | ● | ● | ● | ● | ● | | |
| | | | ø25 | ● | ● | ● | ● | ● | ● | ● | ● | ● | ● | ● | | |
| | | | ø32 | (3) | ● | ● | ● | ● | ● | ● | ● | ● | ● | ● | | |
| | | | ø32 | (3) | ● | ● | ● | ● | ● | ● | ● | ● | ● | ● | | |



- Note 1) Only type E (Reed switch) is applicable as an auto switch when mounting a housing of ø10.
 Note 2) The shock absorbers are to be mounted on the both sides for the 25 stroke of Series CXWM10 to 25.
 Note 3) The shock absorber is to be mounted on one side of the plate for the 25 stroke of Series CXWM20, CXWM32, CXWL32 and the 50 stroke of Series CXWM32.

With end lock
 Shock absorber
 Adjusting bolt
 Housing mounting
 Plate mounting

CX2

CXW

CXT

CXSJ

CXS

D-□

-X□

Individual

-X□

Series CX2/CXWM/CXWL

Prior to Use

Maximum Allowable Moment: CX2N, CXWM, CXWL

Operate within the operating range and under the allowable moment indicated in the table below.

- CX2N
- CXWM (Slide bearing)
- - - CXWL (Ball bushing bearing)

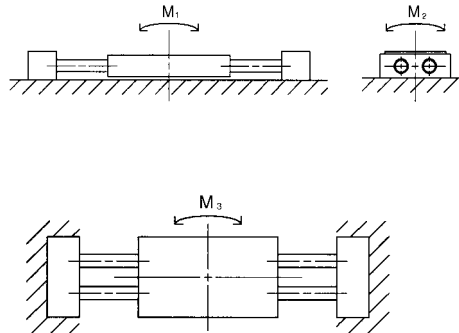
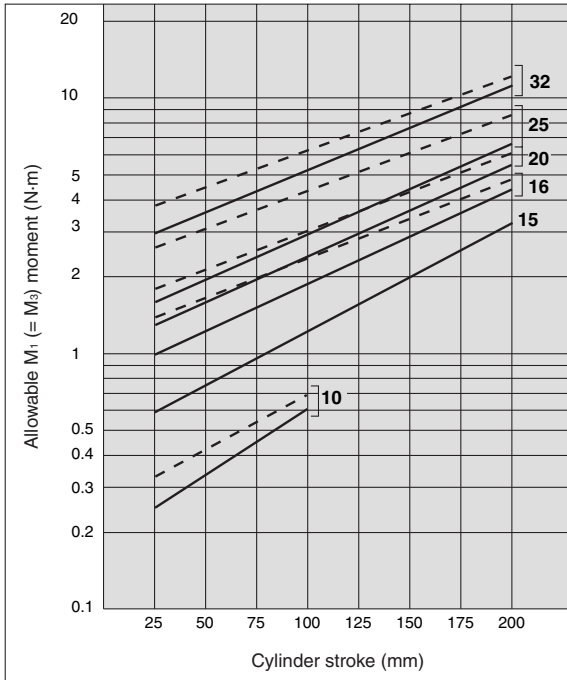

Allowable Moment (M_2) (N·m)

| Bore size (mm) | 10 | 15 | 16 | 20 | 25 | 32 |
|----------------|-------|-------|-------|-------|-------|-------|
| CX2N | 0.098 | 0.294 | — | — | 1.029 | — |
| CXWM | 0.108 | — | 0.549 | 0.809 | 1.029 | 2.695 |
| CXWL | 0.108 | — | 0.549 | 0.809 | 1.201 | 2.695 |

Note) M_2 is steady regardless of the strokes.

Allowable Kinetic Energy

Load mass and cylinder speed should be observed within the range given in the graph below. To adjust the cylinder speed, use a speed controller.

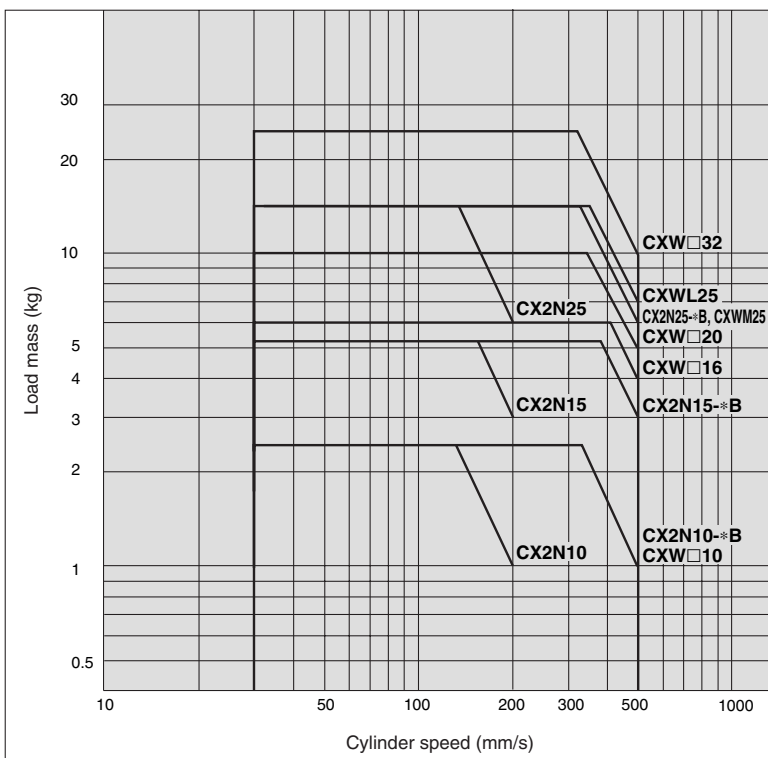

Series CX2

Prior to Use

1. Changing from the non-auto switch specifications to the auto switch specifications
2. Changing mounting style of the auto switch specifications

Series CX2

1. In Series CX2, to change from the specification without auto switch to the plate mounting style with auto switch or to the housing mounting style with auto switch, refer to tables (1) and (2) before ordering.



2. In Series CX2, to change from the plate mounting style with an auto switch to the housing mounting style with an auto switch or vice versa, refer to tables (1) and (2) before ordering.



Table (1) Plate Mounting Style with Auto Switch (CDPX2N□□-□)
Component Parts for Mounting Switches and No. of Component Parts

| Component parts | Material | ø10 | ø15 | ø25 |
|-----------------------|---------------------------------|--|-----------------|-----------------|
| | | Assembly model no. for mounting switch | | |
| | | CDPX2N 10S-□ | CDPX2N 15S-□ | CDPX2N 25S-□ |
| Switch mounting block | Aluminum alloy | 1 | 1 | 1 |
| Block mounting screw | Chrome steel/Nickel plated | 2 | 2 | 2 |
| Switch mounting screw | Chrome steel/Nickel plated | 2 | 2 | 2 |
| Hexagon nut | Carbon steel/Nickel plated | 2 | 2 | 2 |
| Magnet | — | 1(2) ⁽²⁾ | — | — |
| Socket | Brass/Electroless nickel plated | 2 | — | — |
| Plug (M-5P) | Brass/Electroless nickel plated | 2 | 2 | — |

Note 1) "□" mark indicates strokes.

Note 2) In the case of ø10, the 25 mm stroke has two magnets that are bonded in the holes on the side of the housing. Those with strokes of 50 mm to 100 mm have one magnet. Those with other bore sizes have a built-in magnet in their housings.

Table (2) Housing Mounting Style with Auto Switch (CDBX2N□□-□)
Component Parts for Mounting Switches and No. of Component Parts

| Component parts | Material | ø10 | ø15 | ø25 |
|-----------------------------|----------------------------|--|-----------------|-----------------|
| | | Assembly model no. for mounting switch | | |
| | | CDBX2N 10M-□ | CDBX2N 15M-□ | CDBX2N 25M-□ |
| Magnet mounting block ass'y | Aluminum alloy | 1 | 1 | 1 |
| Switch mounting rail | Aluminum alloy | — | 1 | 1 |
| Spacer | Aluminum alloy/Anodized | 2 | — | — |
| Block mounting screw | Chrome steel/Nickel plated | 2 | 2 | 2 |
| Screw for mounting rail | Chrome steel/Nickel plated | — | 2 | 2 |
| Switch mounting screw | Chrome steel/Nickel plated | 2 | 2 | 2 |
| Hexagon nut | Carbon steel/Nickel plated | 2 | 2 | 2 |
| Hexagon socket head plug | Chrome steel/Nickel plated | 2 | 2 | — |

Note 1) "□" mark indicates strokes.

Note 2) For ø10, CX2N10-□ can be changed to CDBX2N10-□, but note that CDPX2N10□ cannot be changed to CDBX2N10-□.

CX2

CXW

CXT

CXSJ

CXS

D-□

-X□

Individual
-X□

Slide Unit/Double Rod Type

Series CX2

Slide Bearing: $\phi 10$, $\phi 15$, $\phi 25$

How to Order

Port thread type

| Symbol | Type | Bore size |
|--------|----------|-----------------------|
| Nil | M thread | $\phi 10$, $\phi 15$ |
| | Rc 1/8 | |
| TN | NPT 1/8 | $\phi 25$ |
| TF | G 1/8 | |

With auto switch

Cylinder with auto switch

| Symbol | Specifications/Mounting |
|--------|---------------------------------------|
| DB | With auto switch/ Housing mounting |
| DP | With auto switch/ Plate mounting |

Type

| | |
|---|---------------------------------------|
| N | Non-lube type |
| H | Air-hydro type (Except $\phi 10$) |

Bore size/Stroke (mm)

| Bore size | Stroke (mm) |
|-----------|-------------------------------------|
| $\phi 10$ | 25, 50, 75, 100 |
| $\phi 15$ | 25, 50, 75, 100, 125, 150, 175, 200 |
| $\phi 25$ | 25, 50, 75, 100, 125, 150, 175, 200 |

For $\phi 15$ and $\phi 25$, strokes up to 300 are available as made-to-order. (-XB11)

Made to Order
* Refer to page 465 for Made to Order specifications.

Number of auto switches

| | |
|-----|----------|
| Nil | 2 pcs. |
| S | 1 pc. |
| n | "n" pcs. |

Auto switch

| | |
|-----|---------------------------------------|
| Nil | Without auto switch (Built-in magnet) |
|-----|---------------------------------------|

* For the applicable auto switch model, refer to the table below.

Cushion (Option)

| | |
|-----|------------------------------|
| Nil | With adjusting bolt (2 pcs.) |
| B | With shock absorber (2 pcs.) |
| BS | With shock absorber (1 pc.) |

Applicable Auto Switch/Refer to pages 1719 to 1827 for further information on auto switches.

| Type | Special function | Electrical entry | Indicator/light | Wiring (Output) | Load voltage | | Auto switch part no. | | Applicable cylinder size | | Lead wire length (m) | | | | Pre-wired connector | Applicable load | | | | | | | | |
|---|--|------------------|-----------------|-----------------|--------------|---------|--------------------------------|---------|--------------------------|----------------|----------------------|---------|--------------|----------|---------------------|-----------------|------------|------------|------------|---|------------|---|---|---|
| | | | | | DC | AC | Electrical entry Perpendicular | In-line | Housing mounting | Plate mounting | 0.5 (Nil) | 3 (L) | 5 (Z) | None (N) | | IC circuit | Relay, PLC | | | | | | | |
| Solid state switch | — | Grommet | Yes | 3-wire (NPN) | 24V | 5V, 12V | — | F7NV | F79 | $\phi 15$ | $\phi 10$ | ● | ● | ○ | — | ○ | IC circuit | Relay, PLC | | | | | | |
| | | | | 3-wire (PNP) | | | | F7PV | F7P | | | ● | ● | ○ | — | ○ | | | | | | | | |
| | Diagnostic indication (2-color indication) | Grommet | Yes | 2-wire | 5V, 12V | — | — | F7BV | J79 | | | ● | ● | ○ | — | ○ | | | — | — | | | | |
| | | | | 3-wire (NPN) | | | | F7NWV | F79W | | | ● | ● | ○ | — | ○ | | | IC circuit | | | | | |
| | Water resistant (2-color indication) | Grommet | Yes | 3-wire (PNP) | 12V | — | — | — | F7PW | | | ● | ● | ○ | — | ○ | | | — | — | | | | |
| | | | | 2-wire | | | | F7BWV | J79W | | | ● | ● | ○ | — | ○ | | | — | — | | | | |
| With diagnostic output (2-color indication) | Grommet | No | 4-wire (NPN) | 24V | 5V, 12V | — | — | F79F | — | ● | ● | ○ | — | ○ | — | — | | | | | | | | |
| — | | | — | | | | — | — | — | — | — | — | — | — | — | — | — | | | | | | | |
| Reed switch | — | Grommet | Yes | 3-wire | 24V | 5V | — | — | A76H | $\phi 15$ | $\phi 10$ | ● | ● | — | — | — | IC circuit | Relay, PLC | | | | | | |
| | | | | 2-wire | | | | 12V | 100V | | | A72 | A72H | ● | ● | — | | | — | — | | | | |
| | | | | 2-wire | | | | 5V, 12V | 100 V or less | | | A73 | A73H | ● | ● | — | | | — | — | IC circuit | | | |
| | | Connector | No | Yes | 2-wire | 24V | 12V | — | — | | | A80 | A80H | ● | ● | — | | | — | — | — | — | | |
| | | | | | 2-wire | | | | | | | 5V, 12V | 24 V or less | A73C | — | ● | | | ● | ● | ● | — | — | — |
| | | | | | 2-wire | | | | | | | 5V, 12V | 24 V or less | A80C | — | ● | | | ● | ● | ● | — | — | — |
| Grommet | No | Yes | 3-wire | 24V | 5V | — | — | — | E76A | $\phi 10$ | — | ● | ● | — | — | — | IC circuit | Relay, PLC | | | | | | |
| | | | 2-wire | | | | | 12V | 100V | | | — | E73A | ● | ● | — | | | — | — | — | | | |
| | | | 2-wire | | | | | 5V, 12V | 100 V or less | | | — | E80A | ● | ● | — | | | — | — | — | — | | |

* Lead wire length symbols: 0.5 m Nil (Example) F79W
 3 m L (Example) F79WL
 5 m Z (Example) F79WZ
 None N (Example) J79CN

* Solid state auto switches marked with "○" are produced upon receipt of order.

* Refer to pages 1784 and 1785 for details of auto switches with a pre-wired connector.

* Auto switches are shipped together (not assembled).

Specifications



| Type | | Non-lube | Air-hydro type |
|---|---------------------|--|---------------------|
| Fluid | | Air | Hydraulic fluid |
| Proof pressure | | 1.5 MPa | |
| Max. operating pressure | | 1.0 MPa | |
| Min. operating pressure | CX2N10 | 0.15 MPa | — |
| | CX2□15 | 0.15 MPa | |
| | CX2□25 | 0.10 MPa | |
| Ambient and fluid temperature | | -10°C to +60°C | |
| Piston speed (Non-lube) | With adjusting bolt | 30 to 200 mm/s | Refer to Table (1). |
| | With shock absorber | 30 to 500 mm/s | |
| Cushion | | With shock absorber (Option) | |
| Stroke adjustable range | | Standard stroke: ±2 mm | |
| Max. load mass ⁽¹⁾ | CX2N10 | 9.8 N | |
| | CX2□15 | 29.4 N | |
| | CX2□25 | 58.8 N | |
| Non-rotating accuracy (Except piston rod deflection) | CX2N10 | ±0.1° | |
| | CX2□15 | ±0.04° | |
| | CX2□25 | ±0.02° | |
| Accessory (Option) | | Straight knock pin (2 pcs.), Adjusting bolt (-X138) ⁽²⁾ Shock absorber | |

Note 1) Place the center of gravity of the load as close to the center of the slide unit as possible during operation. If they are placed far apart, consult with SMC.

Note 2) "-X138" has a stroke adjustable range of 12.5 mm on one side.

Table (1) Air-hydro/Piston Speed

| Model | Plate mounting | Housing mounting |
|---------------|--|------------------|
| CX2H15 | Refer to the below. ^{Note 1)} | 5 to 50 mm/s |
| CX2H25 | 5 to 40 mm/s | 5 to 100 mm/s |

Note 1) Consult with SMC when the air-hydro type is mounted on a plate.

Note 2) Consult with SMC when units are used at a low speed (10 mm/s or faster) (when intermediate stops are not required) since -XB13 (Low speed specification) is available.

Note 3) When using the air-hydro type, use the double side hydro unit.

Shock Absorber Specifications

| Shock absorber | | RB0805 | RB1006 |
|---|------------------|-----------------------|---------------|
| Applicable slide unit | | CX2N10, CX2□15 | CX2□25 |
| Maximum energy absorption (J) | | 0.98 | 3.92 |
| Stroke absorption (mm) | | 5 | 6 |
| Max. collision speed (m/sec) | | 0.05 to 5 | |
| Max. operating frequency (cycle/min) | | 80 | 70 |
| Max. allowable thrust (N) | | 147 | 353 |
| Ambient temperature range (°C) | | -10 to 80 | |
| Spring force (N) | Extended | 1.96 | 4.22 |
| | Retracted | 3.83 | 6.18 |
| Mass (g) | | 15 | 25 |

*The above shows the maximum absorption energy per cycle. Accordingly, the operating frequency can be increased in accordance with the absorption energy.

*The shock absorber service life is different from that of the cylinder body depending on the operating conditions. Refer to the RB Series Specific Product Precautions for the replacement period.



Made to Order Specifications
(For details, refer to pages 1851 to 2021.)

| Symbol | Specifications |
|--------|-----------------------------------|
| —XB11 | Long stroke type |
| —XB13 | Low speed cylinder (5 to 50 mm/s) |
| —X146 | Hollow piston rod |
| —X138 | Adjustable stroke |
| —X168 | CX helical insert thread |
| —X169 | 2 built-in magnets |
| —XC22 | Fluororubber seals |

Theoretical Output

| Model | Rod size (mm) | Piston area (mm ²) | Operating pressure (MPa) | | | | | | | | |
|---------------|---------------|--------------------------------|--------------------------|-----|-----|-----|-----|-----|-----|-----|--|
| | | | 0.2 | 0.3 | 0.4 | 0.5 | 0.6 | 0.7 | 0.8 | 0.9 | |
| CX2N10 | 6 | 101 | 20 | 30 | 40 | 51 | 61 | 71 | 81 | 91 | |
| CX2□15 | 8 | 207 | 41 | 62 | 83 | 104 | 124 | 145 | 166 | 186 | |
| CX2□25 | 14 | 597 | 119 | 179 | 239 | 299 | 358 | 418 | 478 | 537 | |

Note) Theoretical output (N) = Pressure (MPa) x Piston area (mm²)

CX2

CXW

CXT

CXSJ

CXS

D-□

-X□

**Individual
-X□**

Series CX2

Standard Stroke Table

| Model | Basic stroke (mm) | | | | | | | |
|---------------|-------------------|----|----|-----|-----|-----|-----|-----|
| | 25 | 50 | 75 | 100 | 125 | 150 | 175 | 200 |
| CX2N10 | ● | ● | ● | ● | — | — | — | — |
| CX2□15 | ● | ● | ● | ● | ● | ● | ● | ● |
| CX2□25 | ● | ● | ● | ● | ● | ● | ● | ● |

Mass

| Model | Basic stroke (mm) | | | | | | | | (kg) |
|---------------|-------------------|------|------|------|------|------|------|------|------|
| | 25 | 50 | 75 | 100 | 125 | 150 | 175 | 200 | |
| CX2N10 | 0.17 | 0.22 | 0.27 | 0.32 | — | — | — | — | |
| CX2□15 | 0.23 | 0.34 | 0.45 | 0.56 | 0.67 | 0.78 | 0.89 | 1.00 | |
| CX2□25 | 0.93 | 1.15 | 1.36 | 1.58 | 1.80 | 2.01 | 2.29 | 2.45 | |

Operating Direction with Different Pressure Ports

Operating direction of housing when the plate is fixed

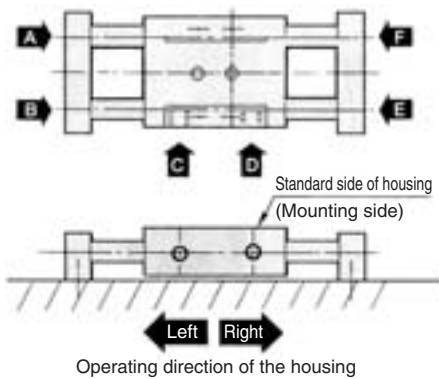

| Pressure port | A | B | C | D | E | F |
|---------------------|-------|------|------|-------|------|-------|
| Operating direction | Right | Left | Left | Right | Left | Right |

* There are 9 possible reciprocating piping methods.

Deflection of Piston Rod by Center Loading (Reference)

When center loading is added to the center of the housing

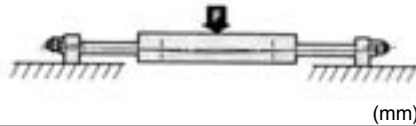

| Model | Stroke Load (N) | 100 | 200 |
|---------------|-----------------|---------------|------|
| | | CX2N10 | 9.8 |
| CX2□15 | 29.4 | 0.08 | 0.28 |
| CX2□25 | 58.8 | 0.02 | 0.08 |

When center loading is added to the center of the plate

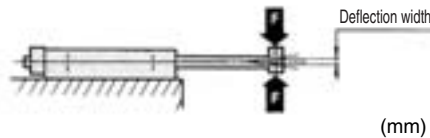

| Model | Stroke Load (N) | 50 | 100 | 150 | 200 |
|---------------|-----------------|---------------|------|------|------|
| | | CX2N10 | 2.94 | 0.06 | 0.30 |
| CX2□15 | 4.90 | 0.09 | 0.22 | 0.50 | 1.0 |
| CX2□25 | 9.81 | 0.03 | 0.09 | 0.16 | 0.25 |

Note) The values denote the total width of the deflections in the upward/downward direction.

Accessory Straight Knock Pin (Option)

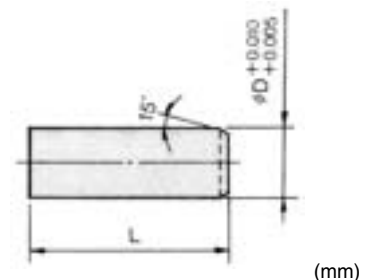

| Model | L | øD | Part no.* |
|---------------|----|----|-----------|
| CX2N10 | 10 | 4 | MS4-10 |
| CX2□15 | 10 | 5 | MS5-10 |
| CX2□25 | 15 | 6 | MS6-15 |

* Manufactured by Misumi Trading Ltd.

Construction/Parts List, Seal List

CX2N10

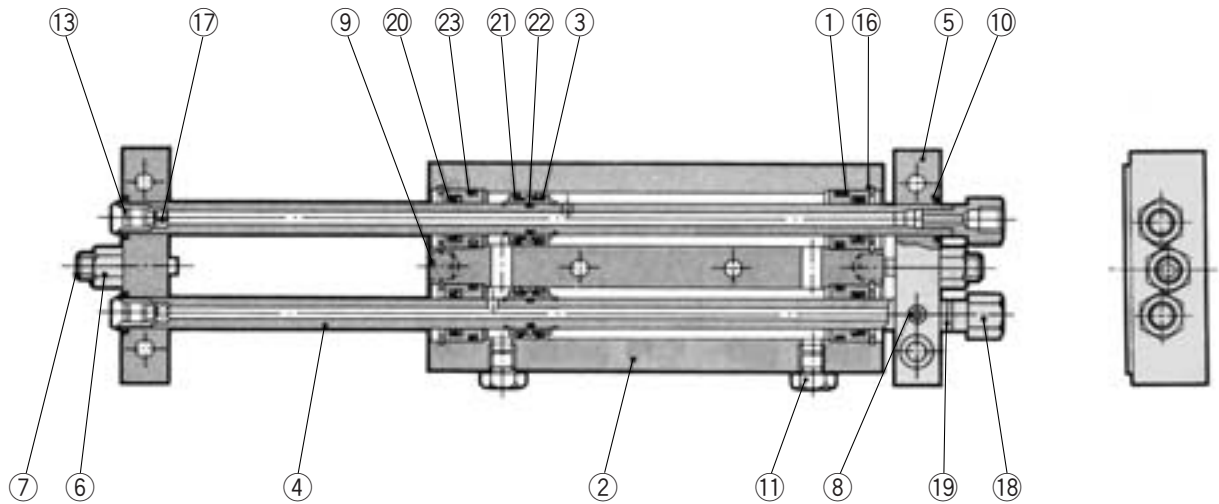

CX2N15, 25

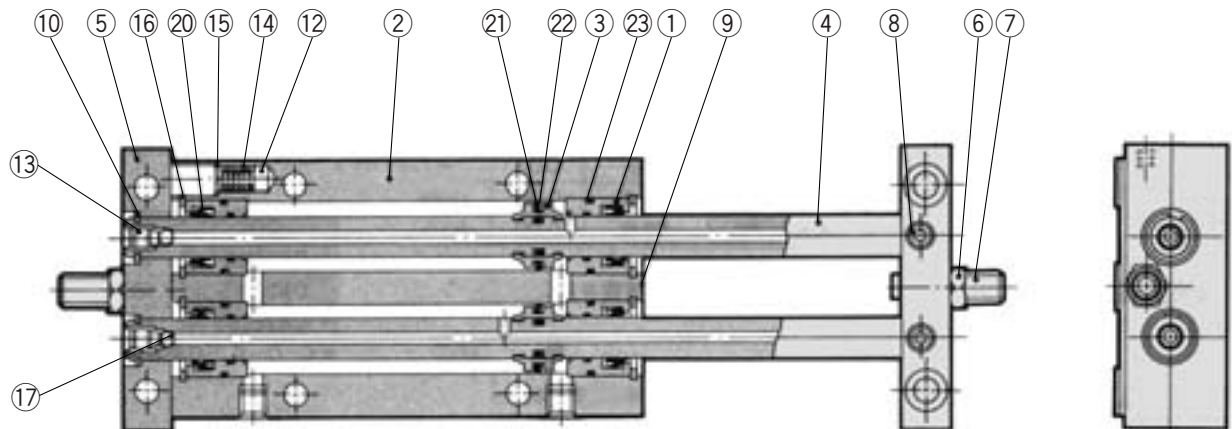

Parts List

| No. | Description | Material | Note |
|-----|-----------------------------|---|--------------------|
| 1 | Rod cover | Aluminum bearing alloy | |
| 2 | Housing | Aluminum alloy | Hard anodized |
| 3 | Piston | Aluminum alloy | |
| 4 | Piston rod | Carbon steel piping for machine constructions | Hard chrome plated |
| 5 | Plate | Aluminum alloy | Anodized |
| 6 | Lock nut | Carbon steel | Nickel plated |
| 7 | Adjusting bolt | Chromium steel | Nickel plated |
| 8 | Set screw (For fixing rods) | Chromium steel | Nickel plated |
| 9 | Pin | Carbon steel | Quenched |
| 10 | Retaining ring | Carbon tool steel | Nickel plated |
| 11 | Plug (M-5P) | Brass | Nickel plated |
| 12 | Magnet | — | |
| 13 | Ball fixing screw | Chromium steel | Nickel plated |
| 14 | Spring | Stainless steel | |
| 15 | Type CR retaining ring | Carbon tool steel | |
| 16 | Round type R retaining ring | Carbon tool steel | Nickel plated |

Parts List

| No. | Description | Material | Note |
|-----|----------------------|----------------------------------|---------------------------|
| 17 | Steel ball | High carbon chrome bearing steel | Heat treated |
| 18 | Socket | Brass | Electroless nickel plated |
| 19 | Gasket | NBR | |
| 20 | Rod seal | | |
| 21 | Piston seal | | |
| 22 | Piston gasket | | |
| 23 | Cylinder tube gasket | | |

Replacement Parts: Seal Kit

| Model | Kit no. | Contents |
|--------|-----------|-------------------------------|
| CX2N10 | CX2N10-PS | A set of ⑳, ㉑, ㉒ listed above |
| CX2N15 | CX2N15-PS | |
| CX2N25 | CX2N25-PS | |

* Seal kit includes ⑳, ㉑, ㉒. Order the seal kit, based on each bore size. (The piston gasket ㉒ is not replaceable.)

* Since the seal kit does not include a grease pack, order it separately.
Grease pack part no.: GR-S-010 (10 g)

CX2

CXW

CXT

CXSJ

CXS

D-

-X

Individual
-X

Series CX2



ø10 Basic Type: CX2N10 - Strokes: 25 to 100

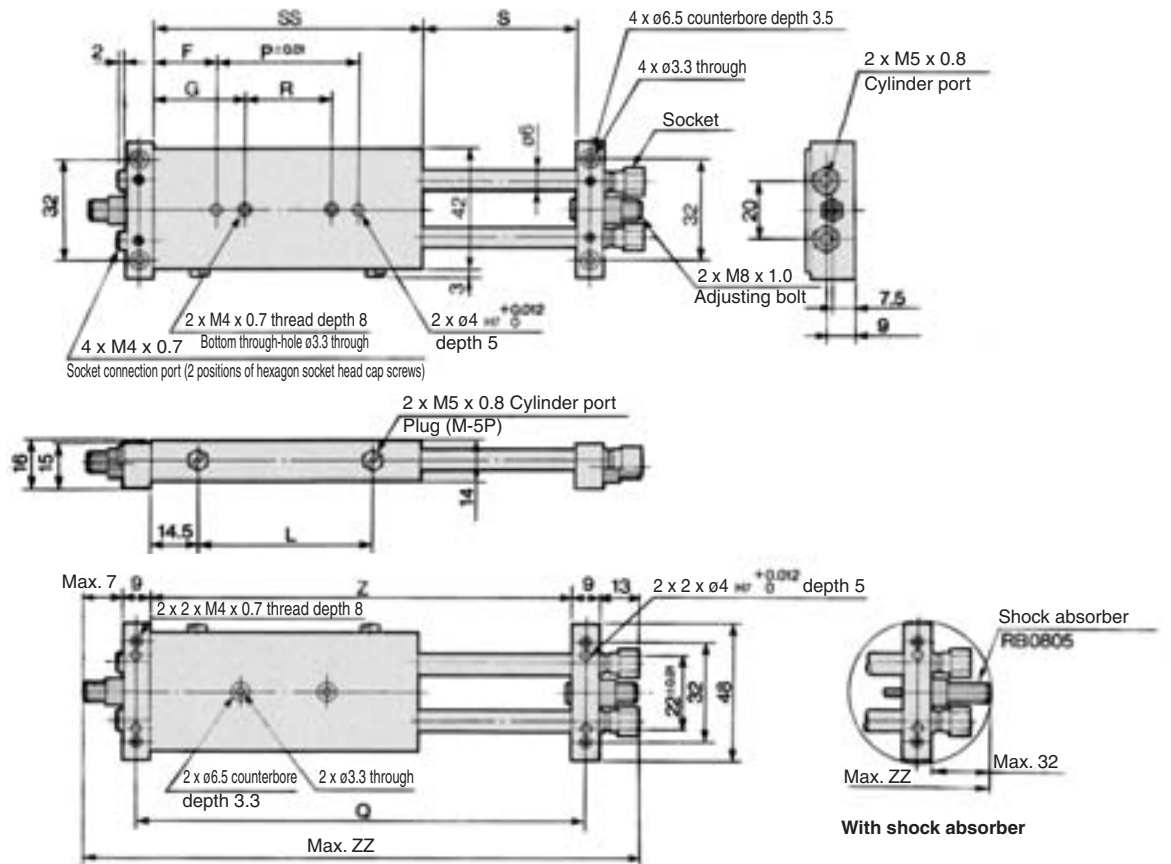

| Model | F | G | L | P | Q | R | S | SS | Z | With adjusting bolt | With shock absorber |
|------------|-----|------|-----|----|-----|----|-----|-----|-----|---------------------|---------------------|
| | | | | | | | | | | ZZ | ZZ |
| CX2N10-25 | 9.5 | 19.5 | 38 | 48 | 103 | 28 | 27 | 67 | 94 | 132 | 176 |
| CX2N10-50 | 20 | 30 | 63 | 52 | 153 | 32 | 52 | 92 | 144 | 182 | 226 |
| CX2N10-75 | 25 | 35 | 88 | 67 | 203 | 47 | 77 | 117 | 194 | 232 | 276 |
| CX2N10-100 | 25 | 35 | 113 | 92 | 253 | 72 | 102 | 142 | 244 | 282 | 326 |

Housing mounting style with auto switch CDBX2N10 - Stroke

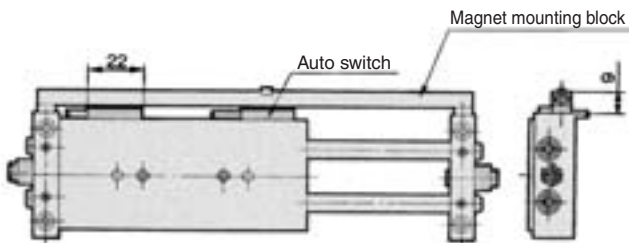

Note 1) The dimensions show D-E7□A and D-E80A.

Plate mounting style with auto switch CDPX2N10 - Stroke

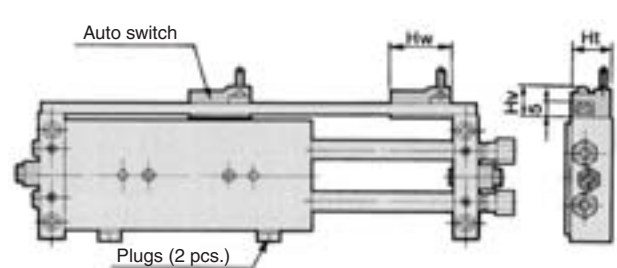

Note 1) The dimensions show D-A7 and D-A8.

| Auto switch model | Hw | Ht | Hv |
|---|----|------|------|
| D-A7, D-A8 | 23 | 15 | 10.5 |
| D-F7□, D-J79, D-J79W, D-F7PW, D-F79F, D-F7BAL, D-F7NTL | 23 | 15 | 11.5 |
| D-A7□H, D-A80H | 22 | 15 | 11.5 |
| D-A73C, D-A80C | 23 | 17.5 | 17.5 |
| D-F7□V | 23 | 15 | 14 |
| D-J79C | 24 | 17.5 | 17 |
| D-F7LF | 30 | 15 | 11.5 |

Note 2) For only 25 strokes, two magnets for auto switches are installed in the housing.



ø15 Basic Type: CX2□15- Strokes: 25 to 200 □

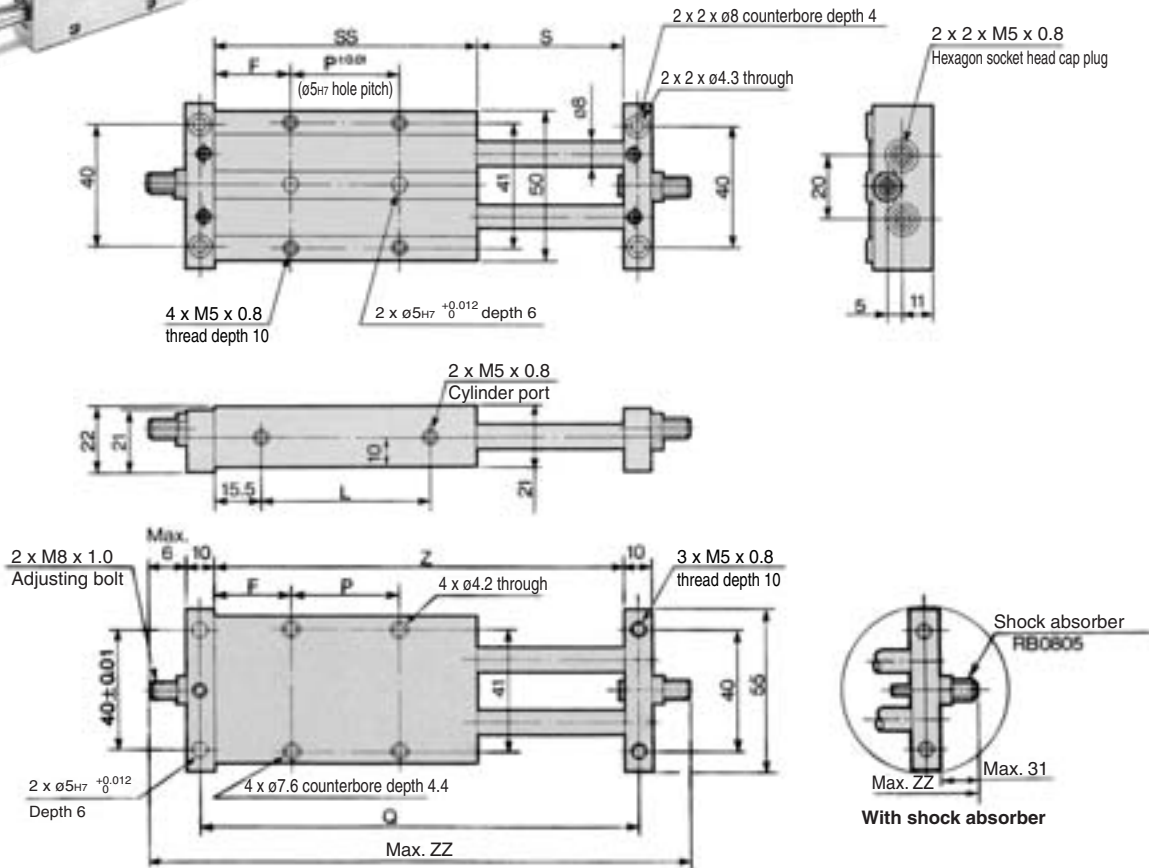

(mm)

| Model | F | L | P | Q | S | SS | Z | With adjusting bolt | With shock absorber |
|-------------|------|-----|----|-----|-----|-----|-----|---------------------|---------------------|
| | | | | | | | | ZZ | ZZ |
| CX2□15-25□ | 24.5 | 38 | 20 | 106 | 27 | 69 | 96 | 128 | 178 |
| CX2□15-50□ | 24.5 | 63 | 45 | 156 | 52 | 94 | 146 | 178 | 228 |
| CX2□15-75□ | 27 | 88 | 65 | 206 | 77 | 119 | 196 | 228 | 278 |
| CX2□15-100□ | 27 | 113 | 90 | 256 | 102 | 144 | 246 | 278 | 328 |
| CX2□15-125□ | 39.5 | 138 | 90 | 306 | 127 | 169 | 296 | 328 | 378 |
| CX2□15-150□ | 52 | 163 | 90 | 356 | 152 | 194 | 346 | 278 | 428 |
| CX2□15-175□ | 64.5 | 188 | 90 | 406 | 177 | 219 | 396 | 428 | 478 |
| CX2□15-200□ | 77 | 213 | 90 | 456 | 202 | 244 | 446 | 478 | 528 |

Housing mounting style with auto switch CDBX2□15- Stroke

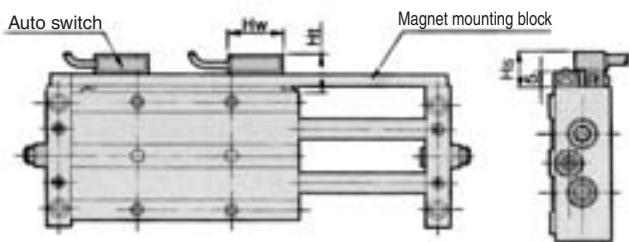

Note 1) The dimensions show D-A7 and D-A8.

| Auto switch model | Hw | Hs | Ht |
|--|----|------|------|
| D-A7, D-A8 | 23 | 12.5 | 15 |
| D-F7□, D-J79, D-J79W, D-F7PW, D-F79F, D-F7BAL, D-F7NTL | 23 | 12.5 | 15 |
| D-A7□H, D-A80H | 22 | 12.5 | 15 |
| D-A73C, D-A80C | 23 | 15 | 17.5 |
| D-F7□V | 23 | 12.5 | 15 |
| D-J79C | 24 | 15 | 17.5 |
| D-F7LF | 30 | 12.5 | 15 |

Note 2) For only 25 strokes, two magnets for auto switches are installed to the magnet mounting block.

Plate mounting style with auto switch CDPX2□15- Stroke

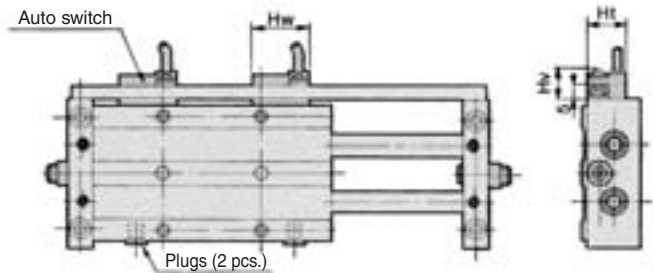

Note 1) The dimensions show D-A7 and D-A8.

| Auto switch model | Hw | Ht | Hv |
|--|----|------|------|
| D-A7, D-A8 | 23 | 15 | 10.5 |
| D-F7□, D-J79, D-J79W, D-F7PW, D-F79F, D-F7BAL, D-F7NTL | 23 | 15 | 11.5 |
| D-A7□H, D-A80H | 22 | 15 | 11.5 |
| D-A73C, D-A80C | 23 | 17.5 | 17.5 |
| D-F7□V | 23 | 15 | 14 |
| D-J79C | 24 | 17.5 | 17 |
| D-F7LF | 30 | 15 | 11.5 |

Note 2) For only 25 strokes, two magnets for auto switches are installed in the housing.

CX2

CXW

CXT

CXSJ

CXS

D-□

-X□

Individual

-X□

Series CX2



ø25 Basic Type: CX2 □ 25 - Strokes: 25 to 200 □

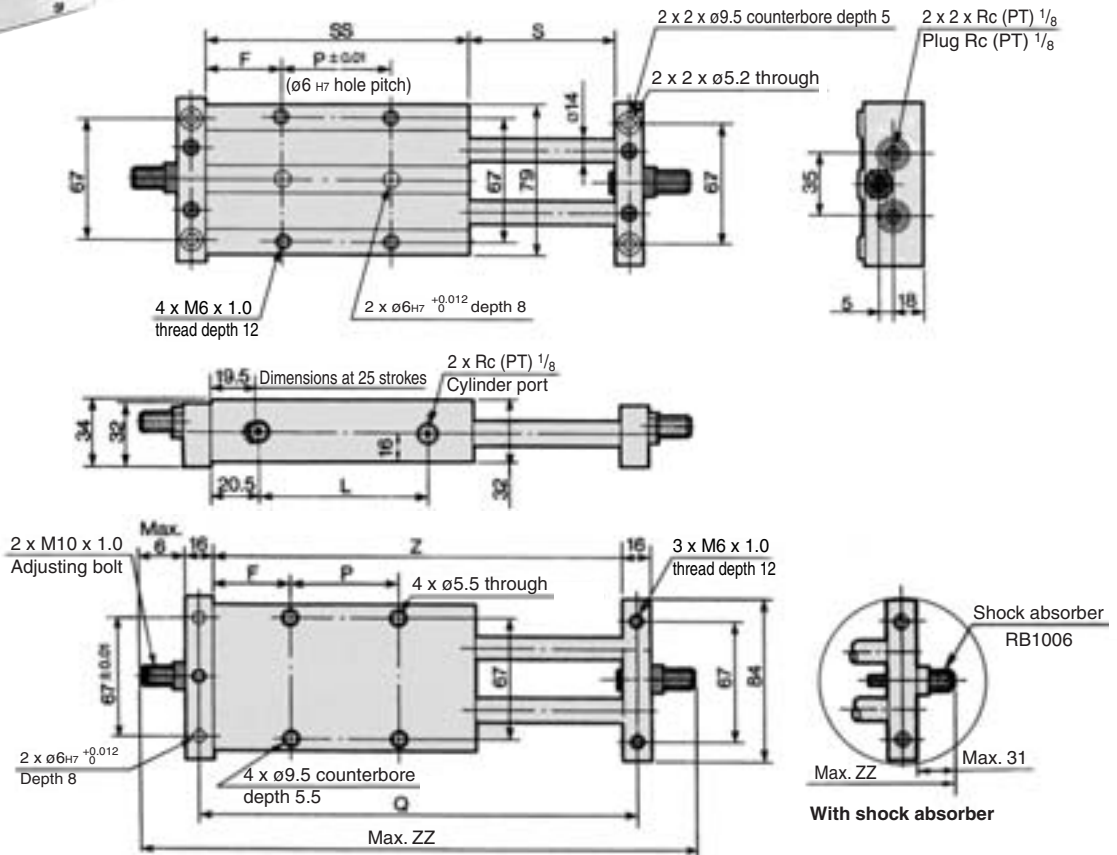

| Model | F | L | P | Q | S | SS | Z | With adjusting bolt | With shock absorber |
|----------------|------|-----|----|-----|-----|-----|-----|---------------------|---------------------|
| | | | | | | | | ZZ | ZZ |
| CX2 □ 25-25 □ | 28.5 | 43 | 25 | 125 | 27 | 82 | 109 | 153 | 203 |
| CX2 □ 25-50 □ | 31 | 66 | 45 | 175 | 52 | 107 | 159 | 203 | 253 |
| CX2 □ 25-75 □ | 33.5 | 91 | 65 | 225 | 77 | 132 | 209 | 253 | 303 |
| CX2 □ 25-100 □ | 33.5 | 116 | 90 | 275 | 102 | 157 | 259 | 303 | 353 |
| CX2 □ 25-125 □ | 46 | 141 | 90 | 325 | 127 | 182 | 309 | 353 | 403 |
| CX2 □ 25-150 □ | 58.5 | 166 | 90 | 375 | 152 | 207 | 359 | 403 | 453 |
| CX2 □ 25-175 □ | 71 | 191 | 90 | 425 | 177 | 232 | 409 | 453 | 503 |
| CX2 □ 25-200 □ | 83.5 | 216 | 90 | 475 | 202 | 257 | 459 | 503 | 553 |

Housing mounting style with auto switch CDBX2 □ 25 - Stroke

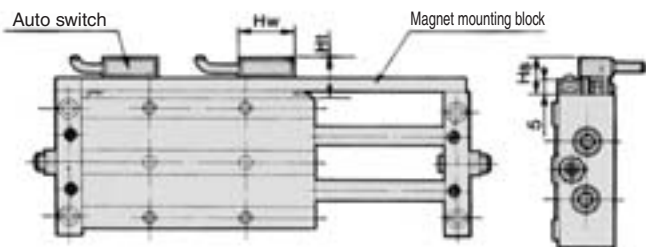

Note 1) The dimensions show D-A7 and D-A8.

| Auto switch model | Hw | Hs | Ht |
|---|----|------|------|
| D-A7, D-A8 | 23 | 12.5 | 15 |
| D-F7 □, D-J79, D-J79W, D-F7PW, D-F79F, D-F7BAL, D-F7NTL | 23 | 12.5 | 15 |
| D-A7 □ H, D-A80H | 22 | 12.5 | 15 |
| D-A73C, D-A80C | 23 | 15 | 17.5 |
| D-F7 □ V | 23 | 12.5 | 15 |
| D-J79C | 24 | 15 | 17.5 |
| D-F7LF | 30 | 12.5 | 15 |

Note 2) For only 25 strokes, two magnets for auto switches are installed to the magnet mounting block.

Plate mounting style with auto switch CDPX2 □ 25 - Stroke

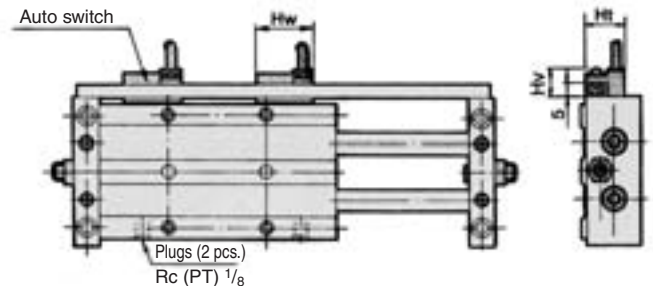

Note 1) The dimensions show D-A7 and D-A8.

| Auto switch model | Hw | Ht | Hs |
|---|----|------|------|
| D-A7, D-A8 | 23 | 15 | 10.5 |
| D-F7 □, D-J79, D-J79W, D-F7PW, D-F79F, D-F7BAL, D-F7NTL | 23 | 15 | 11.5 |
| D-A7 □ H, D-A80H | 22 | 15 | 11.5 |
| D-A73C, D-A80C | 23 | 17.5 | 17.5 |
| D-F7 □ V | 23 | 15 | 14 |
| D-J79C | 24 | 17.5 | 17 |
| D-F7LF | 30 | 15 | 11.5 |

Note 2) For only 25 strokes, two magnets for auto switches are installed in the housing.

Operating Range

(mm)

| Auto switch model | | Applicable cylinder size | | |
|--|------------------|--------------------------|-----|-----|
| | | 10 | 15 | 25 |
| D-A7□/A80 D-A7□H/A80H D-A73C/A80C | Housing mounting | — | 6 | 6 |
| | Plate mounting | 6 | | |
| D-E7□A/E80A | Housing mounting | 6 | — | — |
| D-F7□/J79 D-F7□V/J79C D-F7□W/F7□WV D-F7BAL/F7BAVL D-F79F/F7NTL | Housing mounting | — | 2.5 | 2.5 |
| | Plate mounting | 2.5 | 2.5 | 3 |

* Since the operating range is provided as a guideline including hysteresis, it cannot be guaranteed (assuming approximately ±30% dispersion). It may vary substantially depending on an ambient environment.

Besides the models listed in How to Order, the following auto switches are applicable. Refer to pages 1719 to 1827 for the detailed specifications.

| Auto switch type | Model | Electrical entry (Fetching direction) | Features | Applicable cylinder size | |
|--------------------|---------|---------------------------------------|------------|--------------------------|----------------|
| | | | | Housing mounting | Plate mounting |
| Solid state | D-F7NTL | Grommet (In-line) | With timer | ø15, ø25 | ø10, ø15, ø25 |

* With pre-wired connector is also available for D-F7NTL type. For details, refer to pages 1784 and 1785.
* It is impossible to mount solid state auto switches to the housing mounting ø10.

CX2

CXW

CXT

CXSJ

CXS

D-□

-X□

Individual
-X□

Series CXWM/CXWL

Prior to Use

1. Changing from the non-auto switch specifications to the auto switch specifications
2. Changing mounting style of the auto switch specifications

Series CXW^M_L

1. In Series CXW^M_L, to change from the specification without auto switch to the plate mounting style with auto switch or to the housing mounting style with auto switch, refer to tables (3) and (4) before ordering.



2. In Series CXW^M_L, to change from the plate mounting style with an auto switch to the housing mounting style with an auto switch or vice versa, refer to tables (3) and (4) before ordering.



Table (3) Plate Mounting Style with Auto Switch
(CDPXW^M_L□□-□□) Component Parts for Mounting Switches and No. of Component Parts

| Component parts | Material | ø10 | ø16 | ø20 | ø25 | ø32 |
|-----------------------|---------------------------------|---|---------------------------------------|---------------------------------------|---------------------------------------|---------------------------------------|
| | | Assembly model no. for mounting switch ⁽³⁾ | | | | |
| | | CDPXW ^M _L 10S-□ | CDPXW ^M _L 16S-□ | CDPXW ^M _L 20S-□ | CDPXW ^M _L 25S-□ | CDPXW ^M _L 32S-□ |
| Switch mounting block | Aluminum alloy | 1 | 1 | 1 | 1 | 1 |
| Block mounting screw | Chrome steel/Nickel plated | 2 | 2 | 2 | 2 | 2 |
| Switch mounting screw | Chrome steel/Nickel plated | 2 | 2 | 2 | 2 | 2 |
| Hexagon nut | Carbon steel/Nickel plated | 2 | 2 | 2 | 2 | 2 |
| Magnet | — | 1 (2) ⁽²⁾ | — | — | — | — |
| Socket | Brass/Electroless nickel plated | 2 | — | — | — | — |
| Plug (M-5P) | Brass/Electroless nickel plated | 2 | 2 | 2 | — | — |

Note 1) "□" mark indicates strokes.

Note 2) In the case of ø10, the 25 mm stroke has two magnets that are bonded in the holes on the side of the housing. Those with strokes of 50 mm to 100 mm have one magnet. Those with other bore sizes have a built-in magnet in their housings.

Note 3) For the assembly model no. for mounting switch, order with CDPXWM□□-□□ for Series CXWM and order with CDPXWL□□-□□ for Series CXWL respectively.

Table (4) Housing Mounting Style with Auto Switch
(CDBXW^M_L□□-□□) Component Parts for Mounting Switches and No. of Component Parts

| Component parts | Material | ø10 | ø16 | ø20 | ø25 | ø32 |
|--------------------------------|----------------------------|--|---------------------------------------|---------------------------------------|---------------------------------------|---------------------------------------|
| | | Assembly model no. for mounting switch | | | | |
| | | CDBXW ^M _L 10M-□ | CDBXW ^M _L 16M-□ | CDBXW ^M _L 20M-□ | CDBXW ^M _L 25M-□ | CDBXW ^M _L 32M-□ |
| Magnet mounting block assembly | Aluminum alloy | 1 | 1 | 1 | 1 | 1 |
| Switch mounting rail | Aluminum alloy | — | 1 | 1 | 1 | 1 |
| Spacer | Aluminum alloy/Anodized | 2 | — | — | — | — |
| Block mounting screw | Chrome steel/Nickel plated | 2 | 2 | 2 | 2 | 2 |
| Screw for mounting rail | Chrome steel/Nickel plated | — | 2 | 2 | 2 | 2 |
| Switch mounting screw | Chrome steel/Nickel plated | 2 | 2 | 2 | 2 | 2 |
| Hexagon nut | Carbon steel/Nickel plated | 2 | 2 | 2 | 2 | 2 |
| Hexagon socket head plug | Chrome steel/Nickel plated | 2 | 2 | 2 | — | — |

Note 1) "□" mark indicates strokes.

Note 2) In the case of ø10, CDPXW^M_L10-□ can NOT be changed to CDBXW^M_L10-□. (CXW^M_L10-□ can be changed to CDBXW^M_L10-□)

Note 3) For the assembly model no. for mounting switch, order with CDBXWM□□-□□ for Series CXWM and order with CDBXWL□□-□□ for Series CXWL respectively.

Slide Unit: Built-in Shock Absorber Slide Bearing Type

Series CXWM

ø10, ø16, ø20, ø25, ø32

How to Order

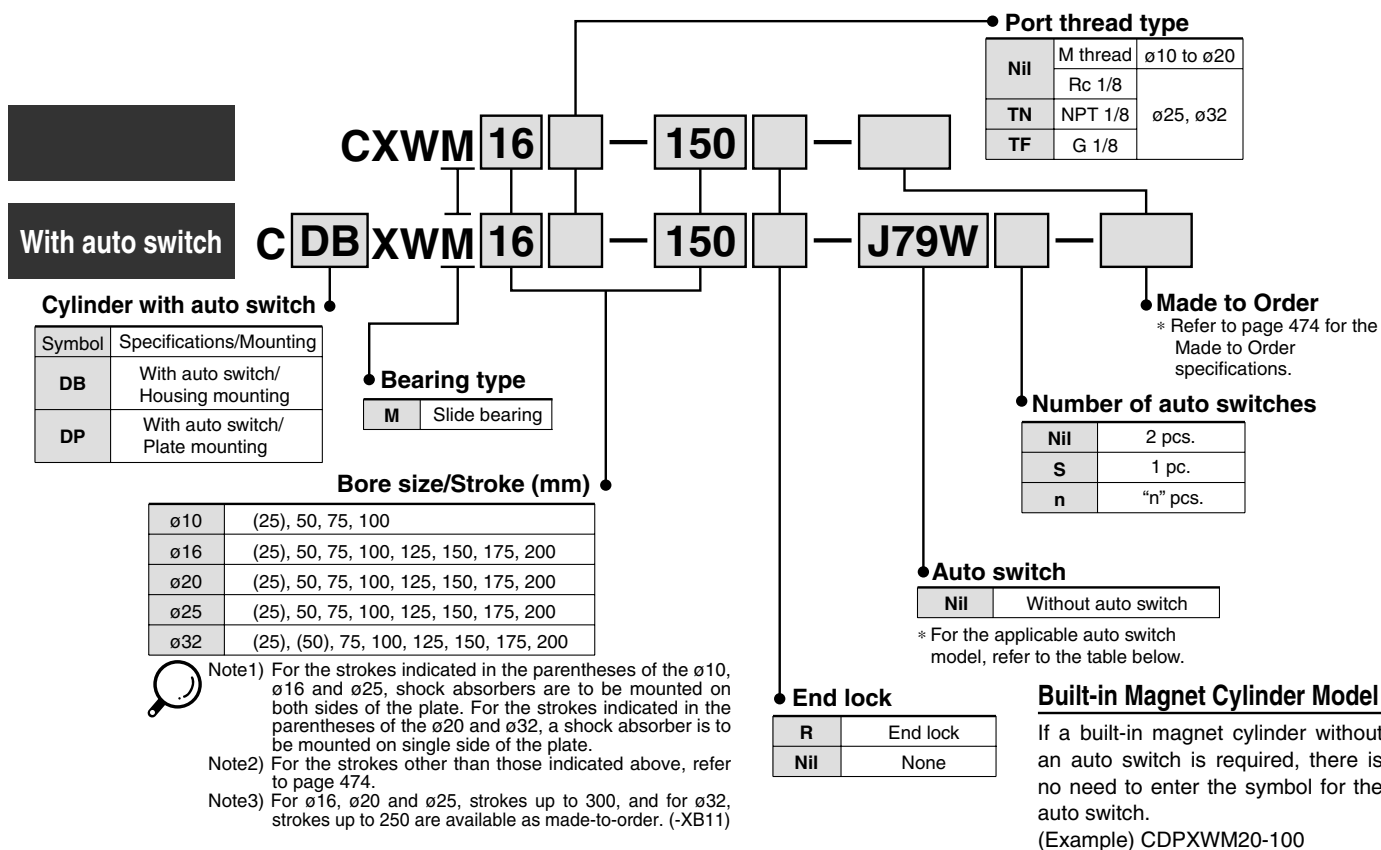

Applicable Auto Switch/Refer to pages 1719 to 1827 for further information on auto switches.

| Type | Special function | Electrical entry | Indicator light | Wiring (Output) | Load voltage | | Rail mounting | | Applicable cylinder size | | Lead wire length (m) * | | | | Pre-wired connector | Applicable load | | |
|---|--|------------------|-----------------|-----------------|---------------|-----------|---------------|---------|--------------------------|--------------------------|---------------------------------|------------|---------------|----------|---------------------|-----------------|------------|------------|
| | | | | | DC | AC | Perpendicular | In-line | Housing mounting | Plate mounting | 0.5 (Nil) | 3 (L) | 5 (Z) | None (N) | | IC circuit | Relay, PLC | |
| Solid state switch | - | Grommet | Yes | 3-wire (NPN) | 24 V | 5 V, 12 V | - | F7NV | F79 | ø16 ø20 ø25 ø32 | ø10 ø16 ø20 ø25 ø32 | ● | ● | ○ | — | ○ | IC circuit | Relay, PLC |
| | | | | 3-wire (PNP) | | | | F7PV | F7P | | | ● | ● | ○ | — | ○ | | |
| | | 2-wire | | F79C | — | ● | ● | ● | — | | | — | — | | | | | |
| | Diagnostic indication (2-color indication) | Grommet | | 3-wire (NPN) | 5 V, 12 V | F7NVV | F79W | ● | ● | | | ○ | — | ○ | IC circuit | | | |
| | | | | 3-wire (PNP) | | — | F7PW | ● | ● | | | ○ | — | ○ | | | | |
| | | 2-wire | | 12 V | F7BWW | J79W | ● | ● | ○ | | | — | ○ | | | | | |
| Water resistant (2-color indication) With diagnostic output (2-color indication) | Grommet | 4-wire (NPN) | 5 V, 12 V | — | F79F | — | ● | ● | ○ | — | ○ | IC circuit | | | | | | |
| | | Reed switch | Grommet | Yes | 24 V | 5 V | — | — | A76H | ø16 ø20 ø25 ø32 | ø10 ø16 ø20 ø25 ø32 | ● | ● | — | — | — | IC circuit | — |
| | | | | | | | | | | | | No | Yes/No | 2-wire | 24 V | 5 V, 12 V | | |
| No | Yes/No | 2-wire | 24 V | 5 V, 12 V | 100 V or less | A73 | A73H | ● | ● | | | | | | | | | |
| | | | | | | No | Yes/No | 2-wire | 24 V | | | 5 V, 12 V | 24 V or less | A80 | A80H | ● | | |
| No | Yes/No | 2-wire | 24 V | 5 V, 12 V | 24 V or less | | | | | | | | | A73C | — | ● | | |
| | | | | | | No | Yes/No | 2-wire | 24 V | | | 5 V, 12 V | 100 V or less | A80C | — | ● | | |
| No | Yes/No | 2-wire | 24 V | 5 V | — | | | | | — | E76A | | | ø10 | — | ● | ● | — |
| | | | | | | No | Yes/No | 2-wire | 24 V | | | 100 V | — | | | — | E73A | ● |
| No | Yes/No | 2-wire | 24 V | 5 V, 12 V | 100 V or less | | | | | — | E80A | | | | | | | ● |

- * Lead wire length symbols: 0.5 m Nil (Example) F79W
3 m L (Example) F79WL
5 m Z (Example) F79WZ
None N (Example) J79CN
- * Solid state auto switches marked with "○" are produced upon receipt of order.
** It is impossible to mount solid state switches to the housing mounting ø10.
- Since there are other applicable auto switches than listed, refer to page 517 for details.
 - For details about auto switches with pre-wired connector, refer to pages 1784 and 1785.
 - * Auto switches are shipped together (not assembled).

Series CXWM

Built-in shock absorber

This is a built-in shock absorber style in which the shock absorber is enclosed in the housing. Compared to Series CX2 with shock absorber, this style achieves space savings in the longitudinal direction (except 25 mm stroke).

Dramatically reduced installation labor

The machining precision required for positioning during the installation of the cylinder has been reduced through the adoption of a special pin hole machining process, thus decreasing the amount of labor involved in adjustment.

Provided with an end lock mechanism

An end lock is also available, which maintains the cylinder's original position even if the air supply is interrupted.

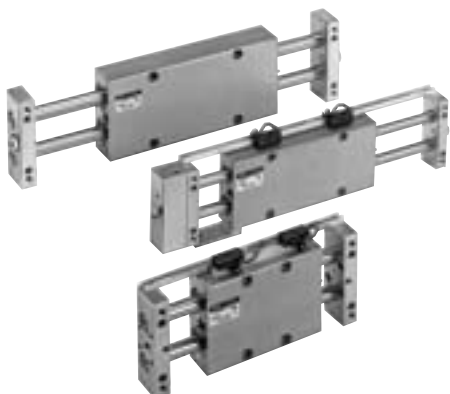

Made to Order Specifications

(For details, refer to pages 1851 to 2021.)

| Symbol | Specifications |
|--------|-----------------------------------|
| —XB11 | Long stroke type |
| —XB13 | Low speed cylinder (5 to 50 mm/s) |
| —XC22 | Fluororubber seal |
| —X146 | Hollow piston rod |
| —X138 | Adjustable stroke |
| —X168 | Helical insert thread |
| —X169 | 2 built-in magnets |

Standard Stroke

| Model | Standard stroke (mm) | | | | | | | |
|-----------|----------------------|--------------|----|-----|-----|-----|-----|-----|
| | 25 | 50 | 75 | 100 | 125 | 150 | 175 | 200 |
| CXWM10-□□ | (1) (*) ● | ● | ● | — | — | — | — | — |
| CXWM16-□□ | (1) (*) ● | ● | ● | ● | ● | ● | ● | ● |
| CXWM20-□□ | (2) (*) ● | ● | ● | ● | ● | ● | ● | ● |
| CXWM25-□□ | (1) (*) ● | ● | ● | ● | ● | ● | ● | ● |
| CXWM32-□□ | (2) (*) ● | (2) (*) ● | ● | ● | ● | ● | ● | ● |

Note 1) The strokes marked with "(*)" has an absorber of double side plate mounting style.
 Note 2) The strokes marked with "(*)" has an absorber of single side plate mounting style.

Specifications

| Type | Non-lube | |
|-----------------------------|--|----------|
| Fluid | Air | |
| Proof pressure | 1.5 MPa | |
| Max. operating pressure | 1.0 MPa | |
| Min. operating pressure | CXWM10/16 | 0.15 MPa |
| | CXWM20/25/32 | 0.1 MPa |
| Ambient & fluid temperature | -10 to 60°C (No freezing) | |
| Piston speed (Non-lube) | 30 to 500 mm/s | |
| Cushion | Shock absorber | |
| Stroke adjustable range | Standard stroke: ±2 mm | |
| Accessory (Option) | Straight knock pin (2 pcs.), Adjusting bolt* (-X138) | |

* "-X138" has a stroke adjustable range of -12.5 mm on one side.

Maximum Load Mass/Non-rotating Accuracy/Maximum Holding Force

| Model | CXWM10 | CXWM16 | CXWM20 | CXWM25 | CXWM32 |
|---|--------|--------|---------|---------|---------|
| Maximum load mass* | 1 kg | 4 kg | 5 kg | 6 kg | 10 kg |
| Non-rotating accuracy (Deflection of a piston rod is not included.) | ±0.09° | ±0.03° | ±0.03° | ±0.02° | ±0.01° |
| Maximum holding force (End lock model) | 39.2 N | 98.1 N | 147.1 N | 245.2 N | 392.3 N |

* Place the center of gravity of the load and center of the slide unit close during operation. If they are placed far apart from each other, please consult with SMC.

Shock Absorber Specifications

| Shock absorber (1) | RB0805-X552 | RB0805 | RB1006-X552 | RB1006 | RB1411-X552 | RB1411 |
|--|--------------|--------|--------------|--------|-------------|--------|
| Applicable slide unit | CXWM10/16-□□ | | CXWM20/25-□□ | | CXWM32-□□ | |
| Maximum energy absorption (J) | 0.98 | | 3.92 | | 14.7 | |
| Stroke absorption (mm) | 5 | | 6 | | 11 | |
| Max. collision speed (m/sec) | 0.05 to 5 | | | | | |
| Max. operating frequency (cycle/min) (2) | 80 | | 70 | | 45 | |
| Max. allowable thrust (N) | 147 | | 353 | | 667 | |
| Ambient temperature range (°C) | -10 to 80 | | | | | |
| Spring force (N) | Extended | 1.96 | | 4.22 | | 6.86 |
| | Retracted | 3.83 | | 6.18 | | 15.30 |
| Mass (g) | 15 | | 25 | | 65 | |



Note 1) "-X552" is an exclusive shock absorber installed in the housing, and is the screw not attached specification of the outer part of the outer tube. The shock absorber plate mounting style of 25 and 50 strokes have the screw attached specification.

Note 2) It denotes the values at the maximum energy absorption per one cycle. Therefore, the operating frequency can be increased according to the energy absorption.

* The shock absorber service life is different from that of the cylinder depending on the operating conditions. Refer to the Series RB Specific Product Precautions for the replacement period.

Theoretical Output

| Model | Rod size (mm) | Piston area (mm ²) | Operating pressure (MPa) | | | | | | | | |
|-----------|---------------|--------------------------------|--------------------------|-----|-----|-----|-----|-----|-----|-----|--|
| | | | 0.2 | 0.3 | 0.4 | 0.5 | 0.6 | 0.7 | 0.8 | 0.9 | |
| CXWM10-□□ | 6 | 101 | 20 | 30 | 40 | 51 | 61 | 71 | 81 | 91 | |
| CXWM16-□□ | 10 | 245 | 49 | 74 | 98 | 123 | 147 | 172 | 196 | 221 | |
| CXWM20-□□ | 12 | 402 | 80 | 121 | 161 | 201 | 241 | 281 | 322 | 362 | |
| CXWM25-□□ | 14 | 597 | 119 | 179 | 239 | 299 | 358 | 418 | 478 | 537 | |
| CXWM32-□□ | 20 | 980 | 196 | 294 | 392 | 490 | 588 | 686 | 784 | 882 | |

Note) Theoretical output (N) = Pressure (MPa) x Piston area (mm²)

Mass (kg)

| Model | Stroke (mm) | | | | | | | |
|---------------|-------------|------|------|------|------|------|------|------|
| | 25 | 50 | 75 | 100 | 125 | 150 | 175 | 200 |
| CXWM10 | 0.28 | 0.35 | 0.42 | 0.49 | – | – | – | – |
| CXWM16 | 0.46 | 0.59 | 0.72 | 0.85 | 0.98 | 1.11 | 1.24 | 1.37 |
| CXWM20 | 0.69 | 0.87 | 1.03 | 1.22 | 1.40 | 1.58 | 1.75 | 1.93 |
| CXWM25 | 0.95 | 1.17 | 1.38 | 1.60 | 1.82 | 2.03 | 2.31 | 2.47 |
| CXWM32 | 2.01 | 2.38 | 2.77 | 3.16 | 3.56 | 3.94 | 4.34 | 4.72 |

Additional Mass with End Lock (CXWM□-□R) (kg)

| Applicable model | Additional mass |
|------------------|-----------------|
| CXWM10 | 0.08 |
| CXWM16 | 0.14 |
| CXWM20 | 0.15 |
| CXWM25 | 0.20 |
| CXWM32 | 0.43 |

**Accessory
Straight Knock Pin (Option)**

Operating Direction with Different Pressure Ports

Operating direction of housing when the plate is fixed

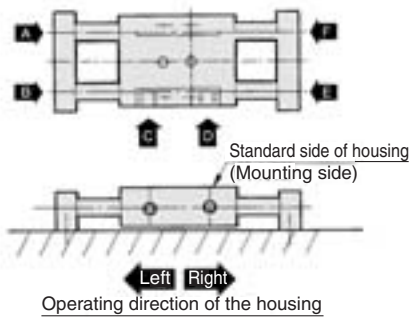

| Pressure port | A | B | C | D | E | F |
|---------------------|-------|------|------|-------|------|-------|
| Operating direction | Right | Left | Left | Right | Left | Right |

* There are 9 possible reciprocating piping methods.

With end lock (CXWM-□R)

Operating direction of housing when the plate is fixed

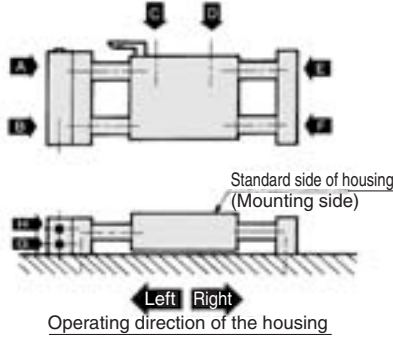

| Pressure port | A | B | C | D | E | F | G | H |
|---------------------|-------|------|------|-------|-------|------|------|-------|
| Operating direction | Right | Left | Left | Right | Right | Left | Left | Right |

* There are 16 possible reciprocating piping methods.

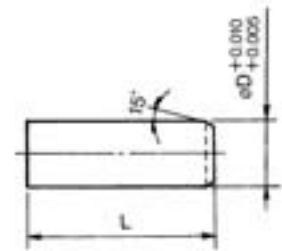

(mm)

| Model | L | øD | Model* |
|---------------|----|----|--------|
| CXWM10 | 10 | 4 | MS4-10 |
| CXWM16 | 10 | 5 | MS5-10 |
| CXWM20 | 15 | 6 | MS6-15 |
| CXWM25 | 15 | 6 | MS6-15 |
| CXWM32 | 20 | 8 | MS8-20 |

* Manufactured by Misumi Trading Ltd.

Deflection of Piston Rod by Center Loading (Reference)

When center loading is added to the center of the housing



(mm)

| Model | Stroke | |
|---------------|----------|------|
| | Load (N) | |
| CXWM10 | 9.81 | 0.07 |
| CXWM16 | 39.2 | 0.05 |
| CXWM20 | 49 | 0.04 |
| CXWM25 | 58.8 | 0.02 |
| CXWM32 | 98.1 | 0.02 |

When center loading is added to the center of the plate



(mm)

| Model | Stroke | | | | |
|---------------|----------|------|------|------|------|
| | Load (N) | 50 | 100 | 150 | 200 |
| CXWM10 | 2.94 | 0.06 | 0.30 | – | – |
| CXWM16 | 4.90 | 0.03 | 0.10 | 0.25 | 0.45 |
| CXWM20 | 7.84 | 0.03 | 0.09 | 0.18 | 0.35 |
| CXWM25 | 9.81 | 0.03 | 0.09 | 0.16 | 0.25 |
| CXWM32 | 29.42 | 0.02 | 0.05 | 0.10 | 0.15 |

Note) The values denote the total width of the deflections in the upward/downward direction.

CX2

CXW

CXT

CXSJ

CXS

D-□

-X□

**Individual
-X□**

Series CXWM

Construction: $\varnothing 10$, $\varnothing 16$, $\varnothing 25$

CXWM10

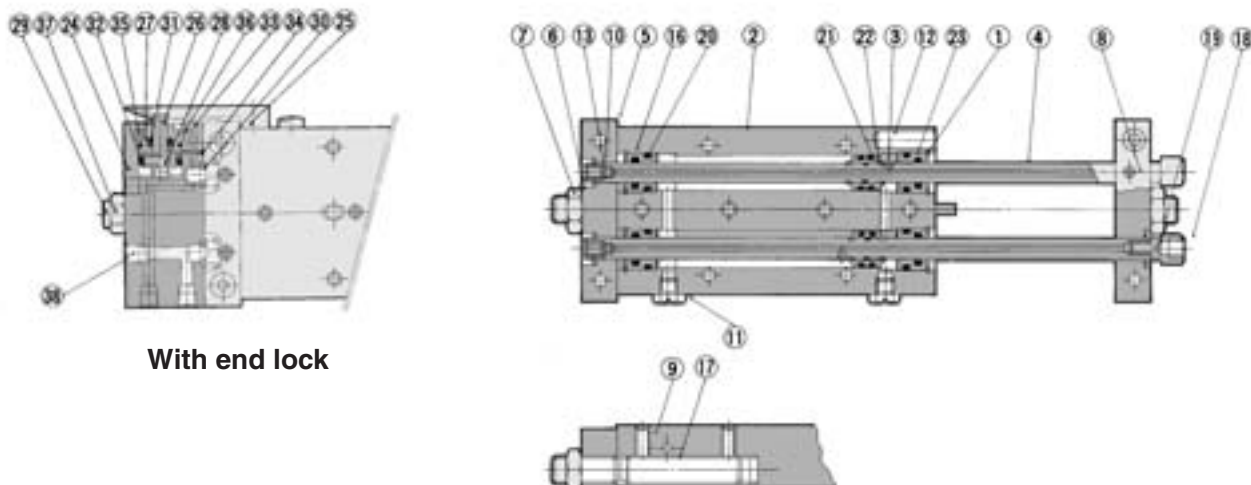

CXWM16, 25

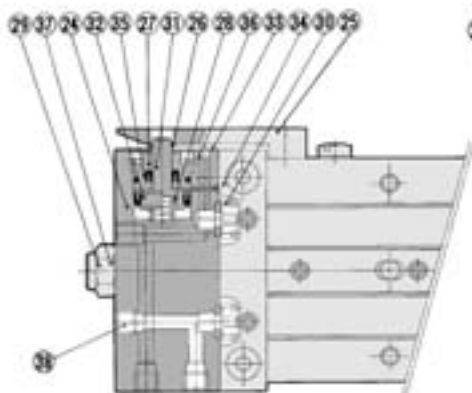

$\varnothing 16$ /With end lock

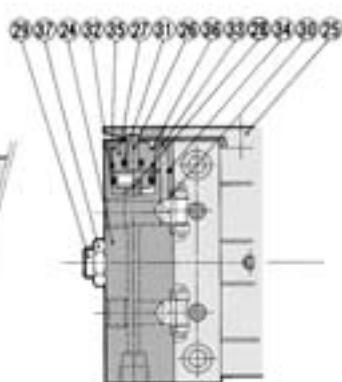

$\varnothing 25$ /With end lock

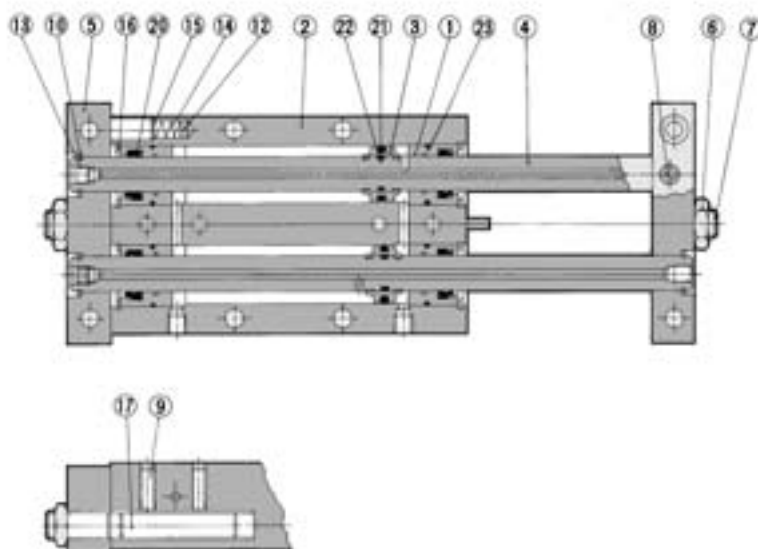

Construction: ø10, ø16, ø25

Component Parts

| No. | Description | Material | Note |
|-----|--|---|------------------------------|
| 1 | Rod cover | Aluminum bearing alloy | |
| 2 | Housing | Aluminum alloy | Hard anodized |
| 3 | Piston | Aluminum alloy | Chromated |
| 4 | Piston rod | Carbon steel piping for machine constructions | Hard chrome plated |
| 5 | Plate | Aluminum alloy | Hard anodized |
| 6 | Lock nut | Carbon steel | Nickel plated |
| 7 | Adjusting bolt | Chromium steel | Nickel plated |
| 8 | Set screw (For fixing rods) | Chromium steel | Nickel plated |
| 9 | Set screw (For fixing shock absorbers) | Stainless steel | |
| 10 | Retaining ring | Carbon tool steel | Nickel plated |
| 11 | Plug | Brass | Nickel plated |
| 12 | Magnet | — | ø5 |
| 13 | Set screw for seal | Chromium steel | Nickel plated |
| 14 | Spring | Stainless steel | |
| 15 | Type CR retaining ring | Carbon tool steel | |
| 16 | Round type R retaining ring | Carbon tool steel | Nickel plated |
| 17 | Shock absorber | — | (RB0805-X552 or RB1006-X552) |
| 18 | Socket | Brass | Electroless nickel plated |
| 19 | Gasket | NBR | |
| 20 | Rod seal | NBR | |
| 21 | Piston seal | NBR | |
| 22 | Piston gasket | NBR | |
| 23 | Cylinder tube gasket | NBR | |

**Replacement Parts: Seal Kit
Cylinder Body**

| Model | Kit no. | Contents |
|--------|-----------|---------------------------|
| CXWM10 | CXWM10-PS | Set of nos. above ⑳, ㉑, ㉒ |
| CXWM16 | CXWM16-PS | |
| CXWM25 | CXWM25-PS | |

- * Seal kit includes ⑳, ㉑, ㉒. Order the seal kit, based on each bore size. (The piston gasket ㉒ is not replaceable.)
- * Since the seal kit does not include a grease pack, order it separately.
Grease pack part no.: GR-S-010 (10 g)

Component Parts: With End Lock

| No. | Description | Material | Note |
|-----|-----------------------------|----------------------------------|--|
| 24 | Locking body | Aluminum alloy | Hard anodized |
| 25 | Lock finger | Alloy tool steel | Nickel plated after quenched |
| 26 | Lock piston | Carbon tool steel | Electroless nickel plated after quenched |
| 27 | Rod cover | Aluminum alloy | |
| 28 | Return spring | Spring steel | Zinc chromated |
| 29 | Adjusting bolt | Chromium steel | Nickel plated |
| 30 | Body gasket | NBR | |
| 31 | Rod seal | NBR | |
| 32 | Piston seal | NBR | |
| 33 | Steel ball | High carbon chrome bearing steel | |
| 34 | Steel ball | High carbon chrome bearing steel | |
| 35 | O-ring | NBR | |
| 36 | Round type R retaining ring | Carbon tool steel | Nickel plated |
| 37 | Lock nut | Carbon steel | Nickel plated |
| 38 | Plug | Chromium steel | Nickel plated |

**Replacement Parts: Seal Kit
End Lock**

| Model | Kit no. | Contents |
|--------|------------|------------------------------|
| CXWM10 | CXWM10R-PS | Set of nos. above ㉓, ㉔, ㉕, ㉖ |
| CXWM16 | CXWM16R-PS | |
| CXWM25 | CXWM25R-PS | |

- * Seal kit includes ㉓, ㉔, ㉕, ㉖. Order the seal kit, based on each bore size.
- * Since the seal kit does not include a grease pack, order it separately.
Grease pack part no.: GR-S-010 (10 g)

CX2

CXW

CXT

CXSJ

CXS

D-□

-X□

Individual
-X□

Series CXWM

Construction: $\varnothing 20$, $\varnothing 32$

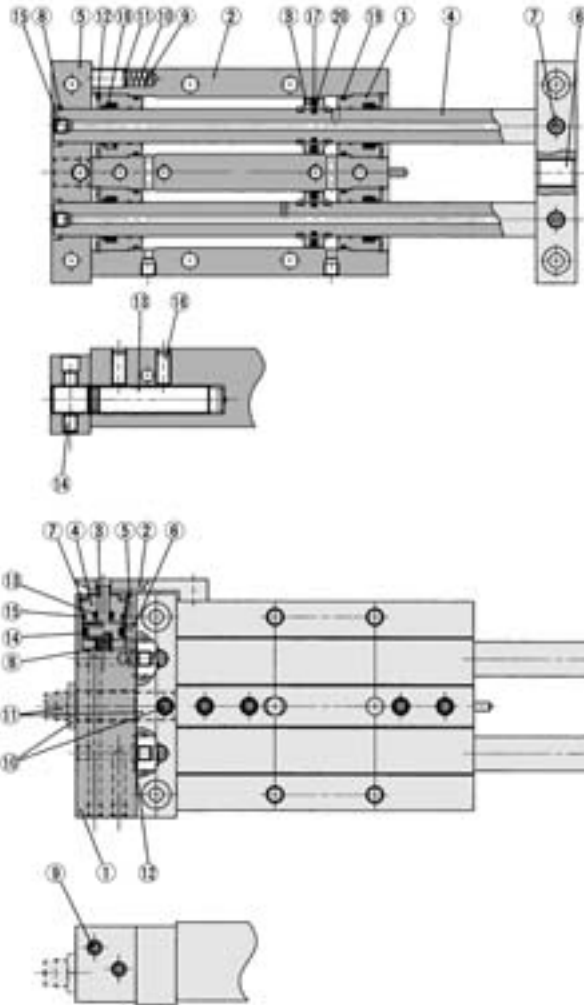

With end lock

Component Parts

| No. | Description | Material | Note |
|-----|-------------------------------|---------------------------|--------------------------|
| 1 | Rod cover | Aluminum bearing alloy | — |
| 2 | Housing | Aluminum alloy | Hard anodized |
| 3 | Piston | Aluminum alloy | Chromated |
| 4 | Piston rod | Carbon steel for machines | Hard chrome plated |
| 5 | Plate | Aluminum alloy | Hard anodized |
| 6 | Adjusting bolt | Chromium steel | Nickel plated |
| 7 | Hexagon socket head set screw | Chromium steel | Nickel plated |
| 8 | Retaining ring | Tool steel | Nickel plated |
| 9 | Magnet | — | |
| 10 | Spring | Stainless steel | |
| 11 | Type CR retaining ring | Carbon tool steel | |
| 12 | Round type R retaining ring | Carbon tool steel | Nickel plated |
| 13 | Shock absorber | — | RB1006-X552, RB1411-X552 |
| 14 | Hexagon socket head set screw | Chromium steel | Nickel plated |
| 15 | Hexagon socket head plug | Chromium steel | Nickel plated |
| 16 | Hexagon socket head set screw | Chromium steel | Nickel plated |
| 17 | Piston seal | NBR | |
| 18 | Rod seal | NBR | |
| 19 | Cylinder tube gasket | NBR | |
| 20 | Piston gasket | NBR | |

Replacement Parts: Seal Kit Cylinder Body

| Model | Kit no. | Contents |
|--------|-----------|------------------------------|
| CXWM20 | CXWM20-PS | Set of nos. above 17, 18, 19 |
| CXWM32 | CXWM32-PS | |

* Seal kit includes 17, 18, 19. Order the seal kit, based on each bore size. (The piston gasket 20 is not replaceable.)

* Since the seal kit does not include a grease pack, order it separately.

Grease pack part no.: GR-S-010 (10 g)

Component Parts: With End Lock

| No. | Description | Material | Note |
|-----|--|----------------------------------|--|
| 1 | Locking body | Aluminum alloy | Hard anodized |
| 2 | Lock finger | Alloy tool steel | Nickel plated after quenched |
| 3 | Lock piston | Tool steel | Electroless nickel plated after quenched |
| 4 | Rod cover | Aluminum bearing alloy | |
| 5 | Steel ball | High carbon chrome bearing steel | |
| 6 | Steel ball | High carbon chrome bearing steel | |
| 7 | Round type R retaining ring | Carbon tool steel | Nickel plated |
| 8 | Return spring | Spring steel | Zinc chromated |
| 9 | Plug | Chromium steel | Nickel plated |
| 10 | (50, 75 to 200) ST Hexagon socket head set screw | Chromium steel | Nickel plated |
| | (25, 50 ST) Hexagon nut | Carbon steel | Nickel plated |
| 11 | (50, 75 to 200) ST Adjusting bolt | Chromium steel | Nickel plated |
| | (25, 50 ST) Shock absorber | — | RB1006 or RB1411 |
| 12 | Body gasket | NBR | |
| 13 | Rod seal | NBR | |
| 14 | Piston seal | NBR | |
| 15 | O-ring | NBR | |

Note) The strokes indicated in the parentheses are of CXWM20, and CXWM32 includes the strokes indicated in the parentheses.

Replacement Parts: Seal Kit End Lock

| Model | Kit no. | Contents |
|--------|------------|----------------------------------|
| CXWM20 | CXWM20R-PS | Set of nos. above 12, 13, 14, 15 |
| CXWM32 | CXWM32R-PS | |

* Seal kit includes 12, 13, 14, 15. Order the seal kit, based on each bore size.

* Since the seal kit does not include a grease pack, order it separately.

Grease pack part no.: GR-S-010 (10 g)

ø10 Basic Type: CXWM10-Stroke/50 to 100

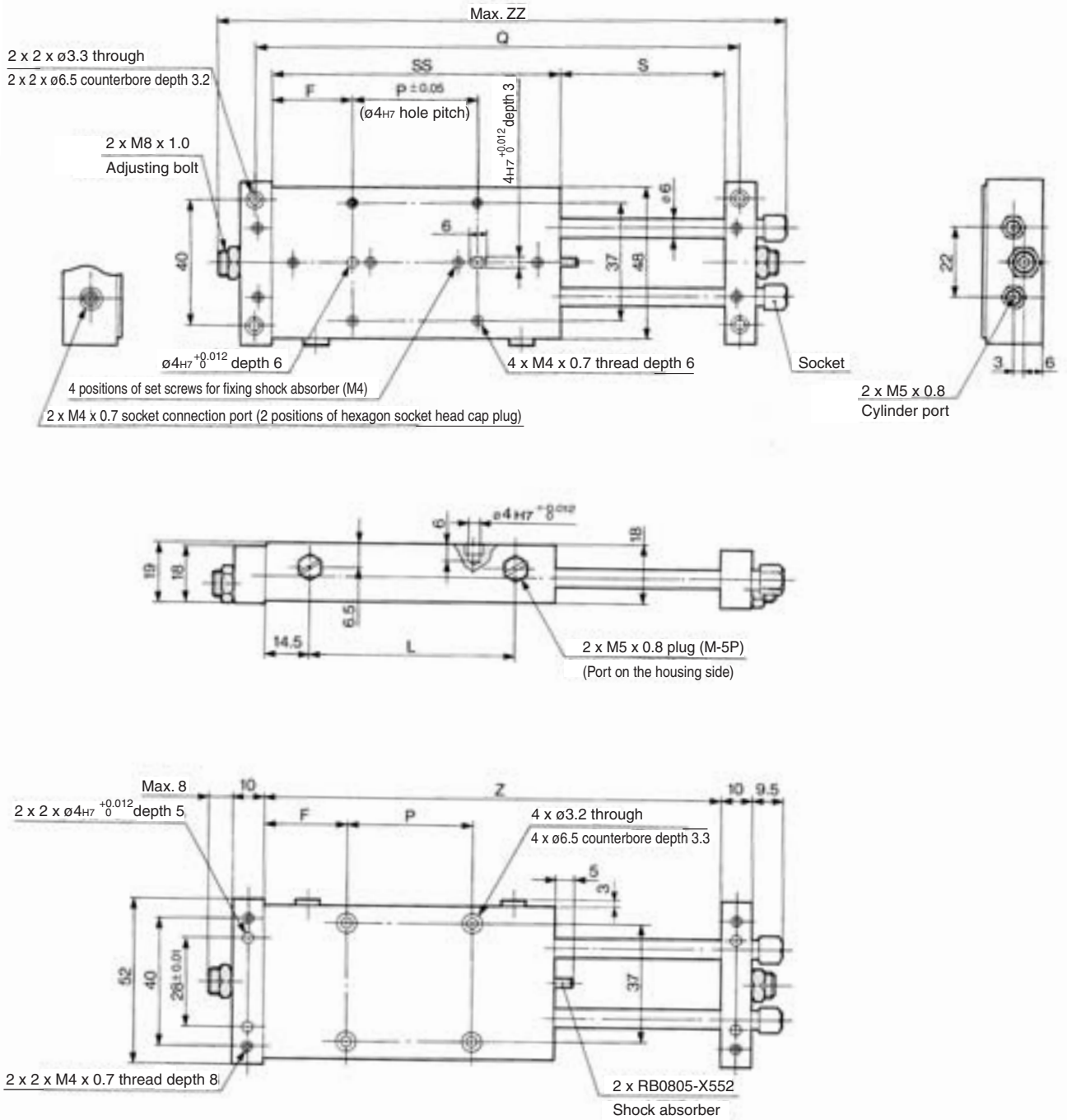

CX2

CXW

CXT

CXSJ

CXS

D-□

-X□

Individual
-X□

(mm)

| Model | F | L | P | Q | S | SS | Z | ZZ |
|-------------------|----|-----|----|-----|-----|-----|-----|-------|
| CXWM10-50 | 26 | 63 | 40 | 154 | 52 | 92 | 144 | 181.5 |
| CXWM10-75 | 26 | 88 | 65 | 204 | 77 | 117 | 194 | 231.5 |
| CXWM10-100 | 26 | 113 | 90 | 254 | 102 | 142 | 244 | 281.5 |



Note) For 25 stroke, the shock absorber is mounted on a plate. For dimensions of the 25 stroke, refer to page 480.

Series CXWM

ø10 Basic Type: CXWM10-25 stroke

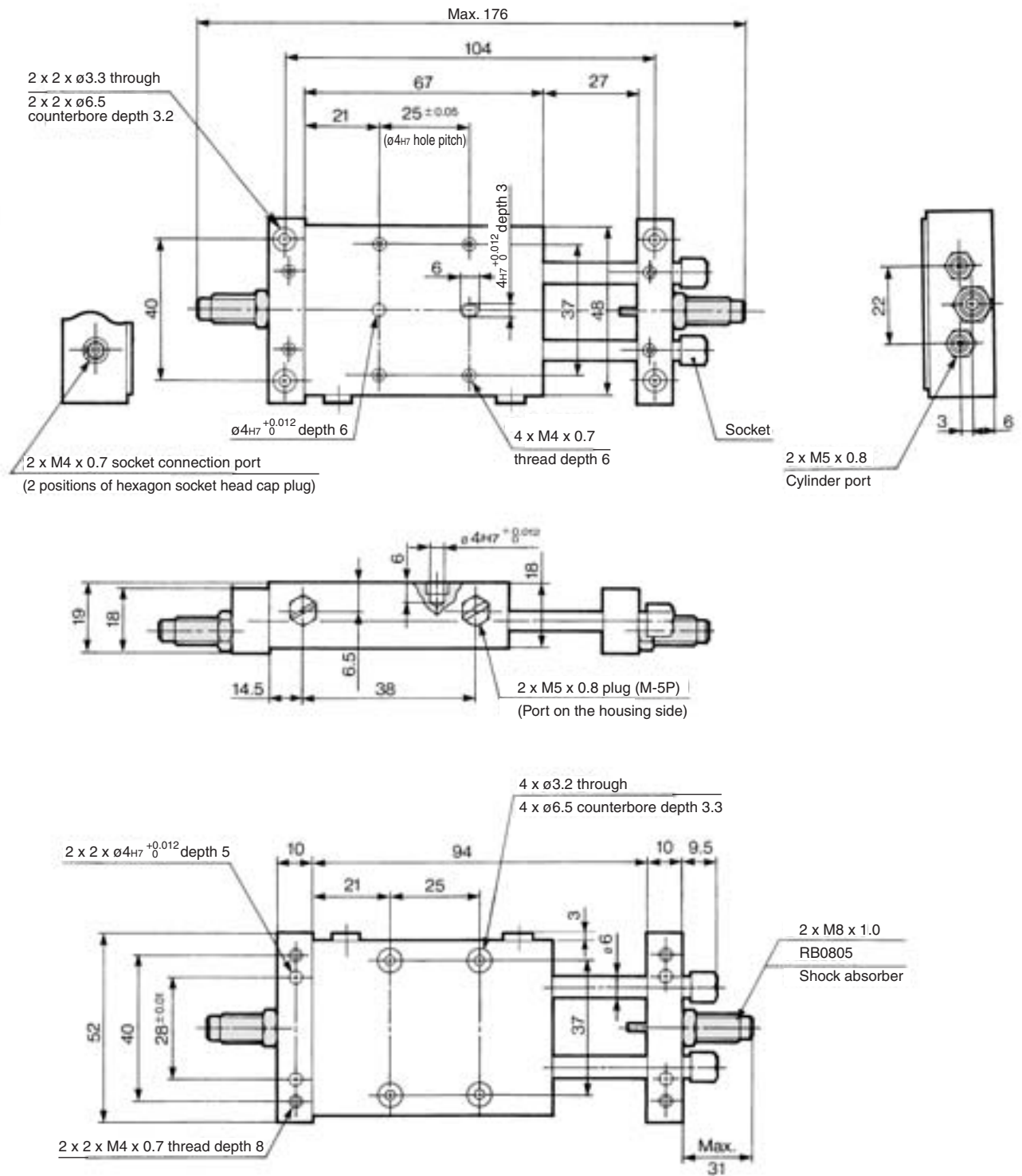

ø10 With End Lock: CXWM10-Stroke/50 to 100 R

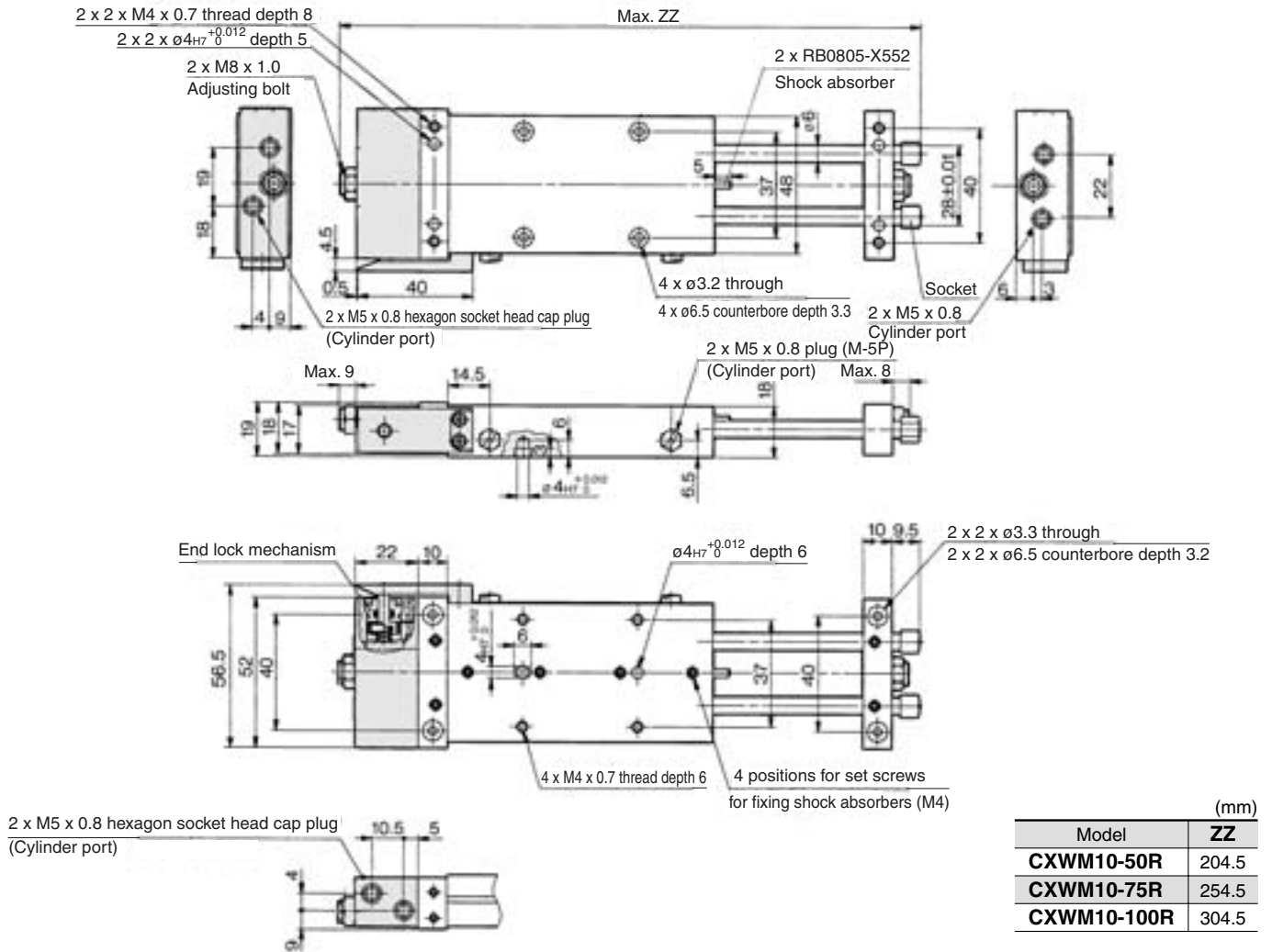

Housing mounting style with auto switch
CDBXWM10-Stroke, CDBXWM10-Stroke R

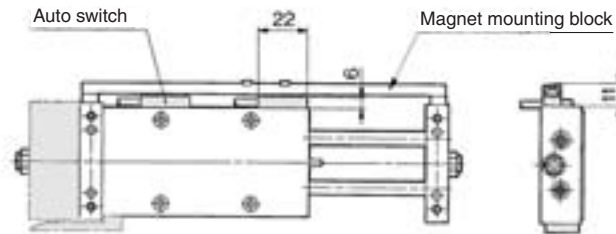
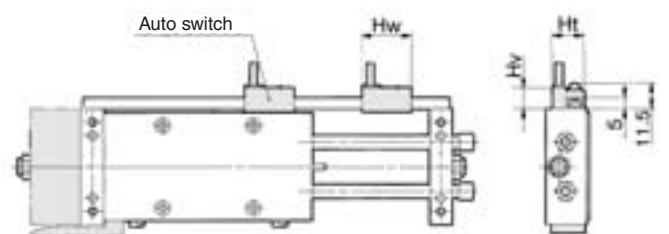

Plate mounting style with auto switch
CDPXWM10-Stroke, CDPXWM10-Stroke R



Note 1) The dimensions show D-E7□A and D-E80A.
Note 2) For 25 stroke, the shock absorber is mounted on a single side of the plate. For dimensions of the 25 stroke, refer to page 482.

Note 1) The dimensions show D-A7 and D-A8. (mm)

| Auto switch model | Hw | Ht | Hv |
|---|----|------|------|
| D-A7□, D-A80 | 23 | 15 | 10.5 |
| D-F7□, D-J79, D-J79W, D-F7□W, D-F79F, D-F7BAL, D-F7NTL | 23 | 15 | 10 |
| D-A7□H, D-A80H | 22 | 15 | 9 |
| D-A73C, D-A80C | 23 | 17.5 | 17.5 |
| D-F7□V, D-F7□WV, D-F7BAV | 23 | 15 | 14 |
| D-J79C | 24 | 17.5 | 16 |

Note 2) For 25 stroke, the shock absorber is mounted on a single side of the plate. For dimensions of 25 stroke, refer to page 482.

CX2
CXW
CXT
CXSJ
CXS

D-□
-X□
Individual
-X□

Series CXWM

ø10 With End Lock: CXWM10-25 Stroke R

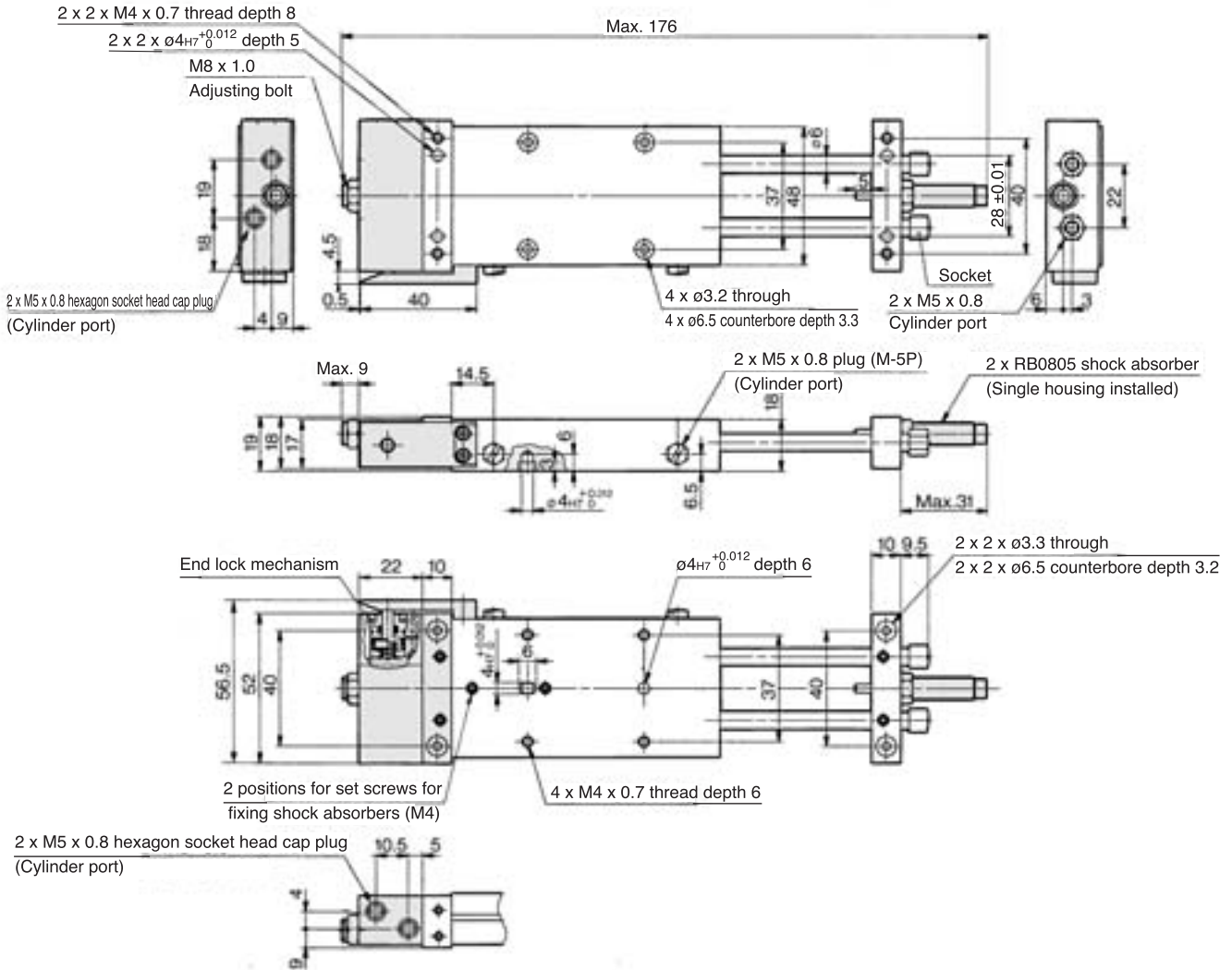

Housing mounting style with auto switch CDBXWM10-25, CDBXWM10-25R

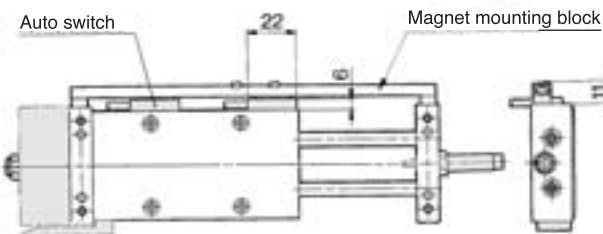
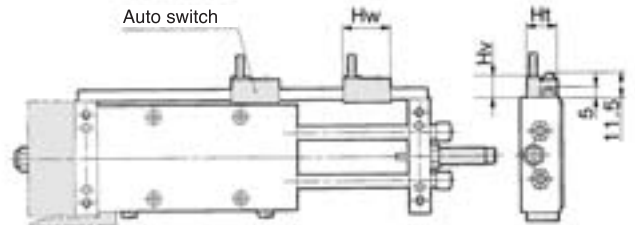

Plate mounting style with auto switch CDPXWM10-25, CDPXWM10-25R



Note 1) The dimensions show D-E7□A and D-E80A.
 Note 2) 2 magnets for auto switches are equipped to the magnet mounting block.

Note 1) The dimensions show D-A7 and D-A8. (mm)

| Auto switch model | Hw | Ht | Hv |
|---|----|------|------|
| D-A7□, D-A80 | 23 | 15 | 10.5 |
| D-F7□, D-J79, D-J79W, D-F7□W, D-F79F, D-F7BAL, D-F7NTL | 23 | 15 | 10 |
| D-A7□H, D-A80H | 22 | 15 | 9 |
| D-A73C, D-A80C | 23 | 17.5 | 17.5 |
| D-F7□V, D-F7□WV, D-F7BAV | 23 | 15 | 14 |
| D-J79C | 24 | 17.5 | 16 |

Note 2) 2 magnets for auto switches are installed in the housing.

Slide Unit: Built-in Shock Absorber Slide Bearing Type **Series CXWM**

ø16 Basic Type: CXWM16-Stroke/50 to 200

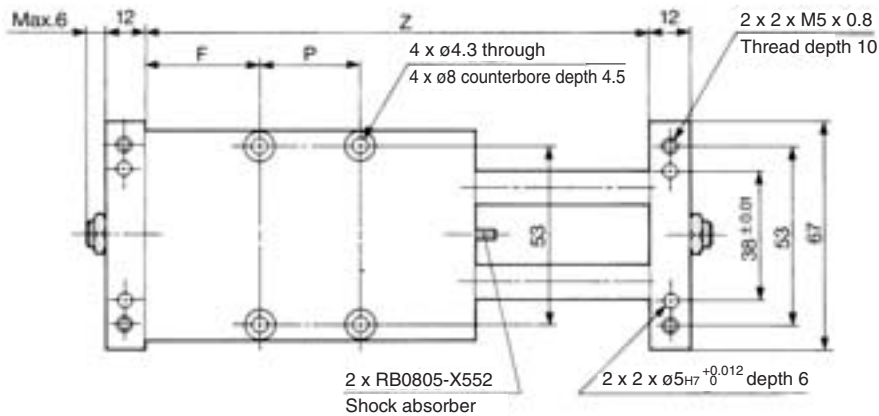
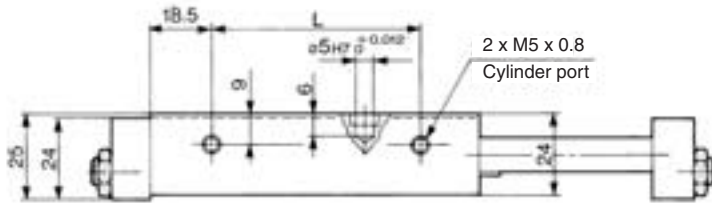
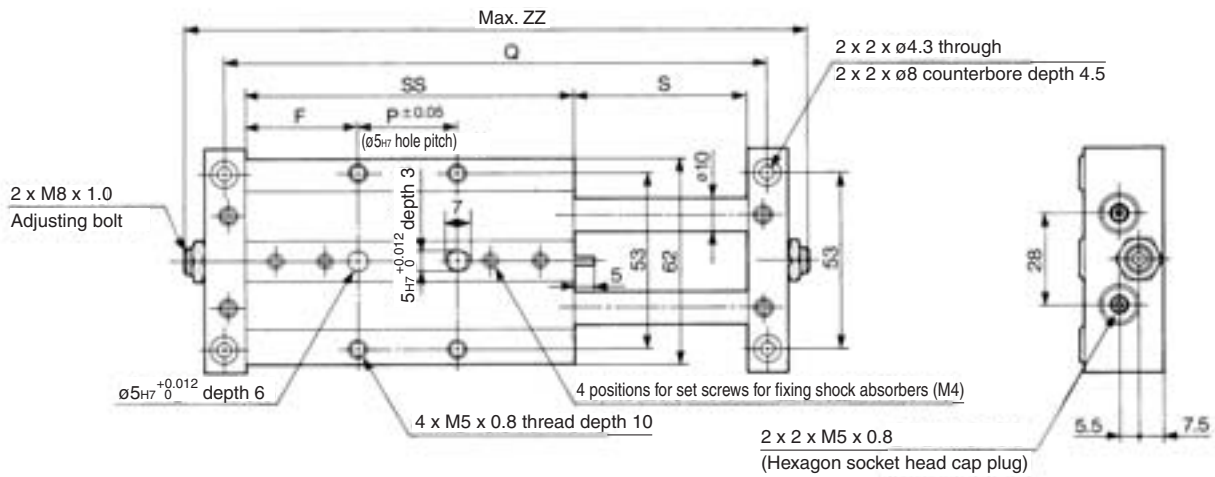

| Model | F | L | P | Q | S | SS | Z | ZZ |
|-------------------|------|-----|----|-----|-----|-----|-----|-----|
| CXWM16-50 | 35 | 63 | 30 | 164 | 52 | 100 | 152 | 188 |
| CXWM16-75 | 32.5 | 88 | 60 | 214 | 77 | 125 | 202 | 238 |
| CXWM16-100 | 37.5 | 113 | 75 | 264 | 102 | 150 | 252 | 288 |
| CXWM16-125 | 42.5 | 138 | 90 | 314 | 127 | 175 | 302 | 338 |
| CXWM16-150 | 55 | 163 | 90 | 364 | 152 | 200 | 352 | 388 |
| CXWM16-175 | 67.5 | 188 | 90 | 414 | 177 | 225 | 402 | 438 |
| CXWM16-200 | 80 | 213 | 90 | 464 | 202 | 250 | 452 | 488 |

(mm)



Note) For 25 stroke, the shock absorber is mounted on a plate.
Refer to page 484 for the dimensions of the 25 stroke.

CX2

CXW

CXT

CXSJ

CXS

D-□

-X□

**Individual
-X□**

Series CXWM

ø16 Basic Type: CXWM16-25 stroke

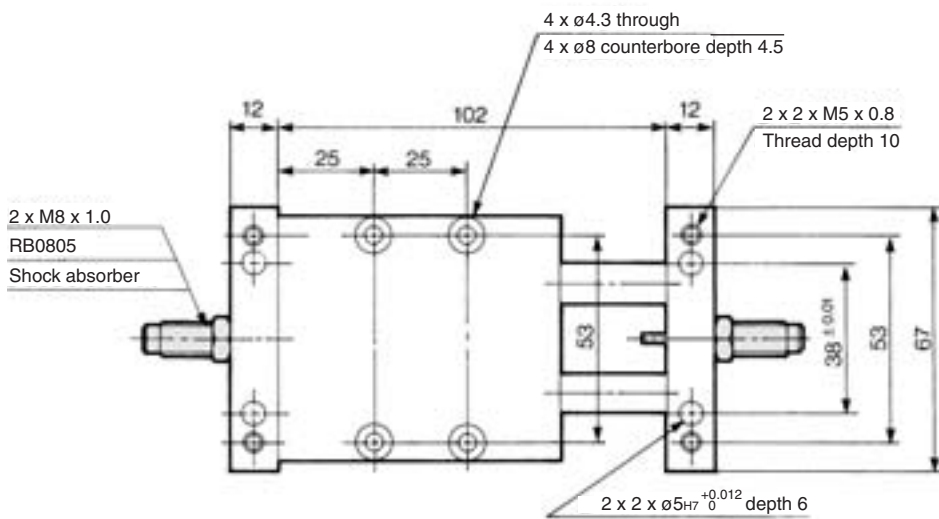
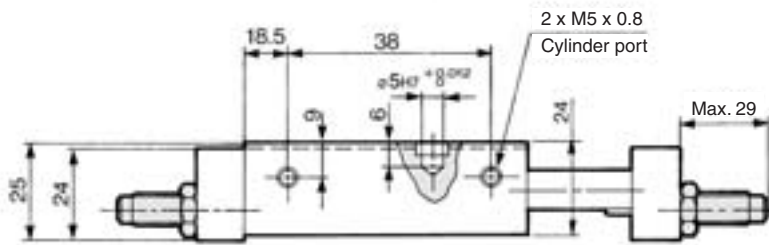
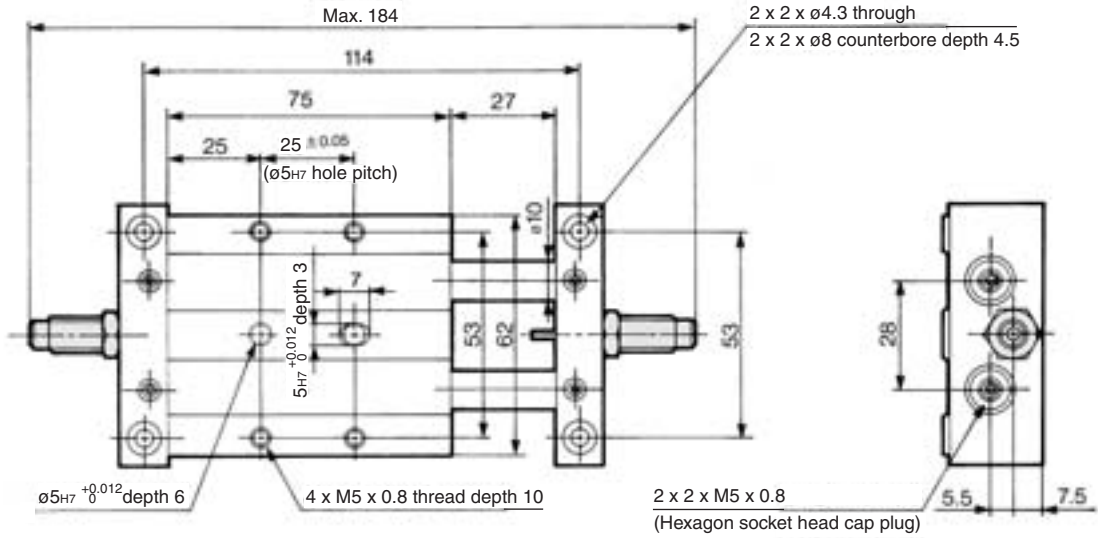

ø16 With End Lock: CXWM16-Stroke/50 to 200 R

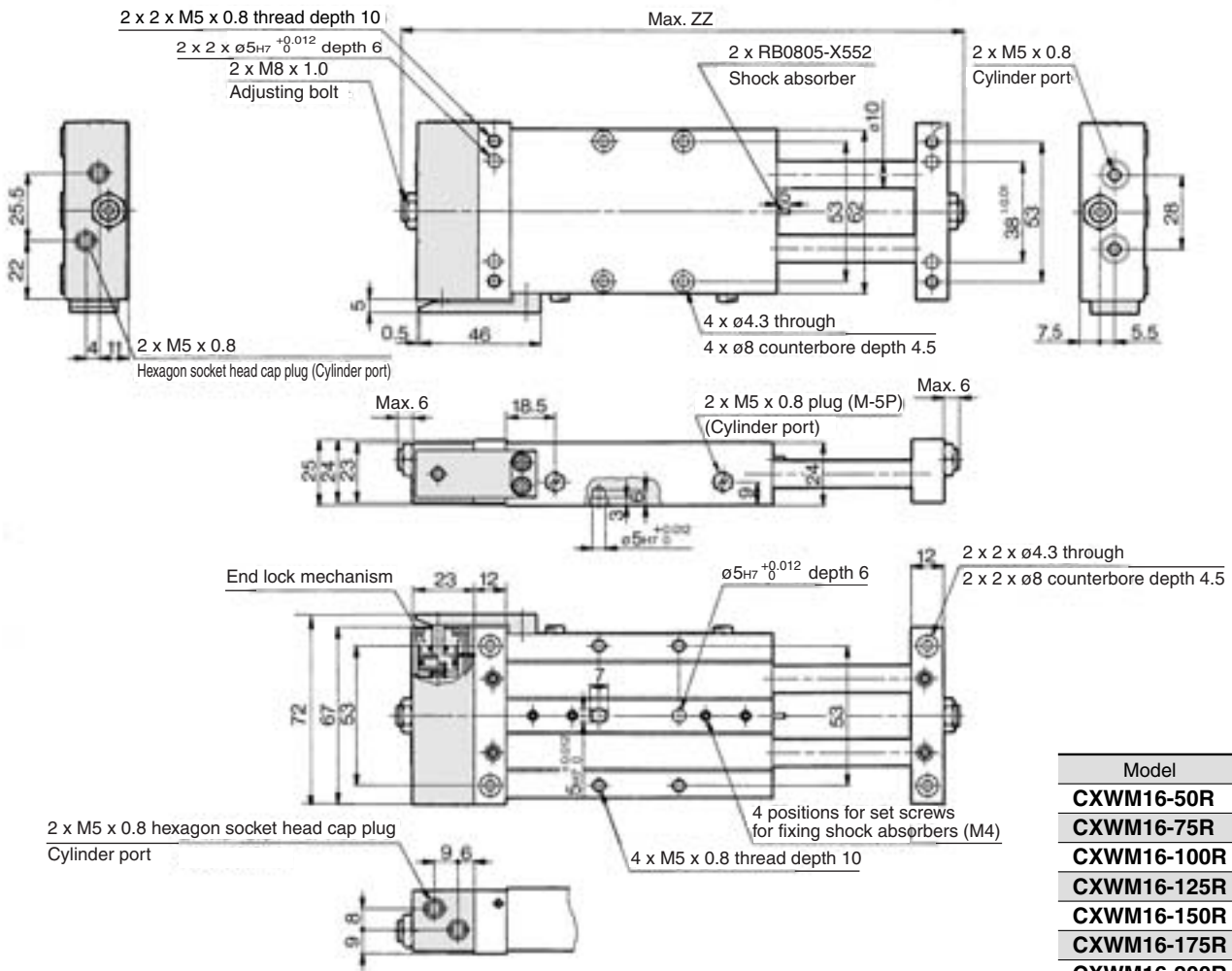

| (mm) | |
|--------------------|-----|
| Model | ZZ |
| CXWM16-50R | 211 |
| CXWM16-75R | 261 |
| CXWM16-100R | 311 |
| CXWM16-125R | 361 |
| CXWM16-150R | 411 |
| CXWM16-175R | 461 |
| CXWM16-200R | 511 |

Housing mounting style with auto switch
CDBXWM16-Stroke, **CDBXWM16-Stroke R**

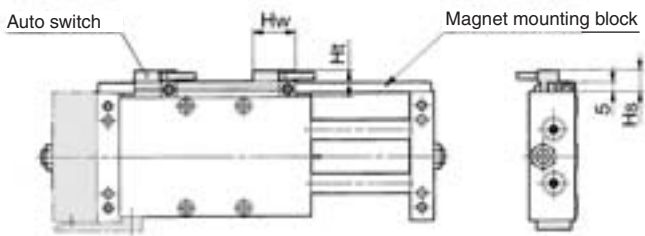

Note 1) The dimensions show D-A7 and D-A8. (mm)

| Auto switch model | Hw | Hs | Ht |
|---|----|------|------|
| D-A7□, D-A80 | 23 | 12.5 | 15 |
| D-F7□, D-J79, D-J79W, D-F7□W, D-F79F, D-F7BAL, D-F7NTL | 23 | 12.5 | 15 |
| D-A7□H, D-A80H | 22 | 12.5 | 15 |
| D-A73C, D-A80C | 23 | 15 | 17.5 |
| D-F7□V, D-F7□WV, D-F7BAV | 23 | 12.5 | 15 |
| D-J79C | 24 | 15 | 17.5 |
| D-F7LF | 30 | 12.5 | 15 |

Note 2) For 25 stroke, the shock absorber is mounted on a single side of the plate. For dimensions of 25 stroke, refer to page 486.

Plate mounting style with auto switch
CDPXWM16-Stroke, **CDPXWM16-Stroke R**

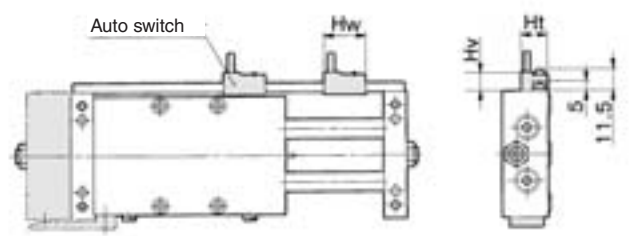

Note 1) The dimensions show D-A7 and D-A8. (mm)

| Auto switch model | Hw | Ht | Hv |
|---|----|------|------|
| D-A7□, D-A80 | 23 | 15 | 10.5 |
| D-F7□, D-J79, D-J79W, D-F7□W, D-F79F, D-F7BAL, D-F7NTL | 23 | 15 | 10 |
| D-A7□H, D-A80H | 22 | 15 | 9 |
| D-A73C, D-A80C | 23 | 17.5 | 17.5 |
| D-F7□V, D-F7□WV, D-F7BAV | 23 | 15 | 14 |
| D-J79C | 24 | 17.5 | 16 |

Note 2) For 25 stroke, the shock absorber is mounted on a single side of the plate. For dimensions of 25 stroke, refer to page 486.

- CX2**
- CXW**
- CXT**
- CXSJ**
- CXS**

- D-□**
- X□**
- Individual -X□**

Series CXWM

ø16 With End Lock: CXWM16-25 stroke R

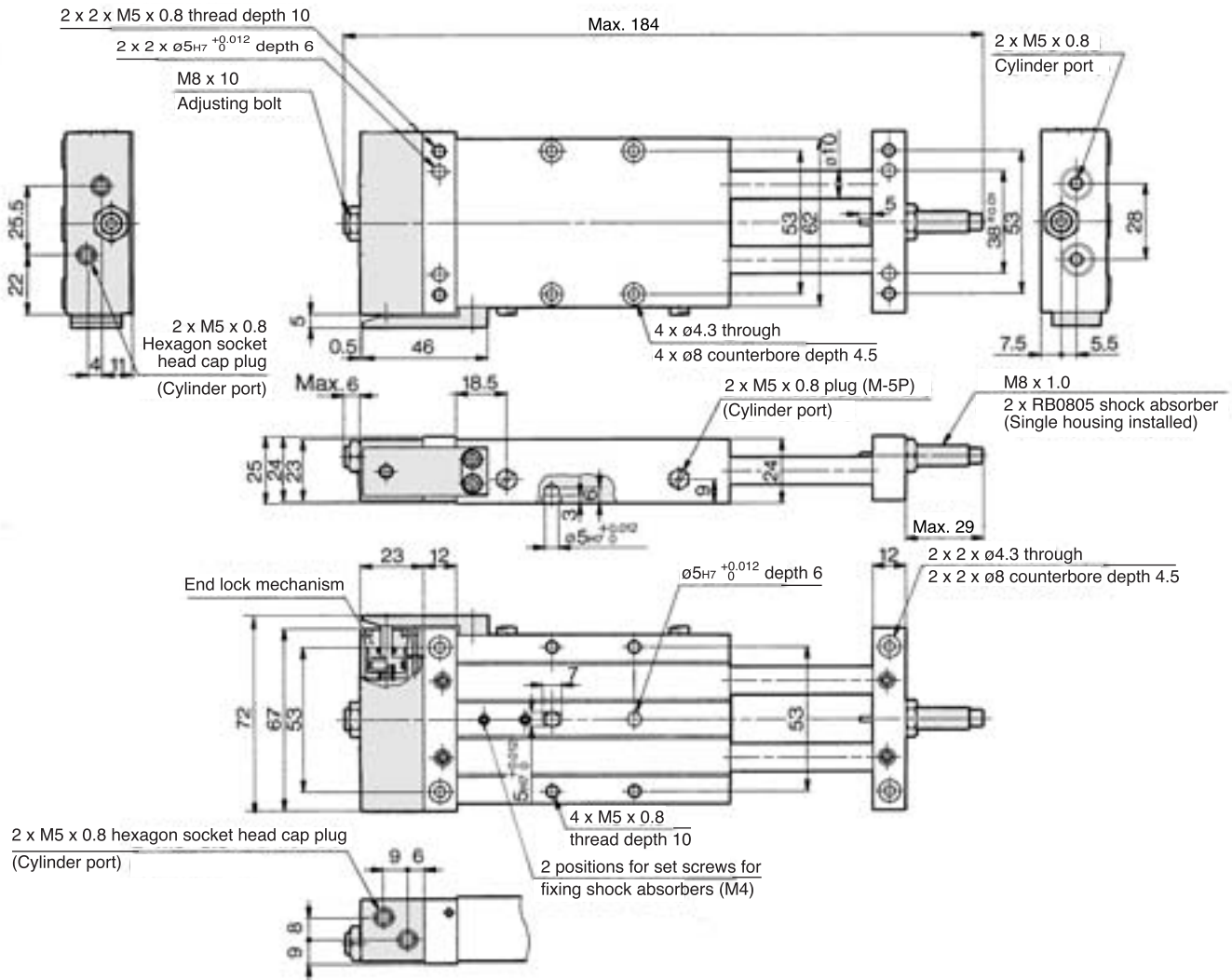

Housing mounting style with auto switch CDBXWM16-25, CDBXWM16-25R

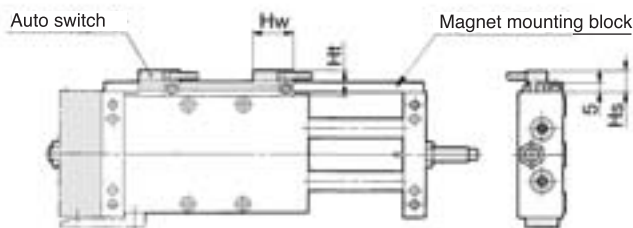

Note 1) The dimensions show D-A7 and D-A8. (mm)

| Auto switch model | Hw | Hs | Ht |
|--|----|------|------|
| D-A7□, D-A80 | 23 | 12.5 | 15 |
| D-F7□, D-J79, D-J79W, D-F7□W, D-F79F, D-F7BAL, D-F7NTL | 23 | 12.5 | 15 |
| D-A7□H, D-A80H | 22 | 12.5 | 15 |
| D-A73C, D-A80C | 23 | 15 | 17.5 |
| D-F7□V, D-F7□WV, D-F7BAV | 23 | 12.5 | 15 |
| D-J79C | 24 | 15 | 17.5 |
| D-F7LF | 30 | 12.5 | 15 |

Note 2) 2 magnets for auto switches are equipped to the magnet mounting block.

Plate mounting style with auto switch CDPXWM16-25, CDPXWM16-25R

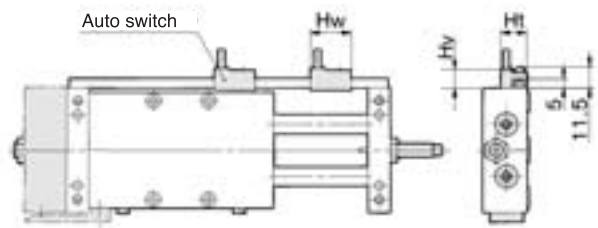

Note 1) The dimensions show D-A7 and D-A8. (mm)

| Auto switch model | Hw | Ht | Hv |
|--|----|------|------|
| D-A7□, D-A80 | 23 | 15 | 10.5 |
| D-F7□, D-J79, D-J79W, D-F7□W, D-F79F, D-F7BAL, D-F7NTL | 23 | 15 | 10 |
| D-A7□H, D-A80H | 22 | 15 | 9 |
| D-A73C, D-A80C | 23 | 17.5 | 17.5 |
| D-F7□V, D-F7□WV, D-F7BAV | 23 | 15 | 14 |
| D-J79C | 24 | 17.5 | 16 |

Note 2) 2 magnets for auto switches are installed in the housing.

Slide Unit: Built-in Shock Absorber
Slide Bearing Type **Series CXWM**

ø20 Basic Type: CXWM20-Stroke/50 to 200

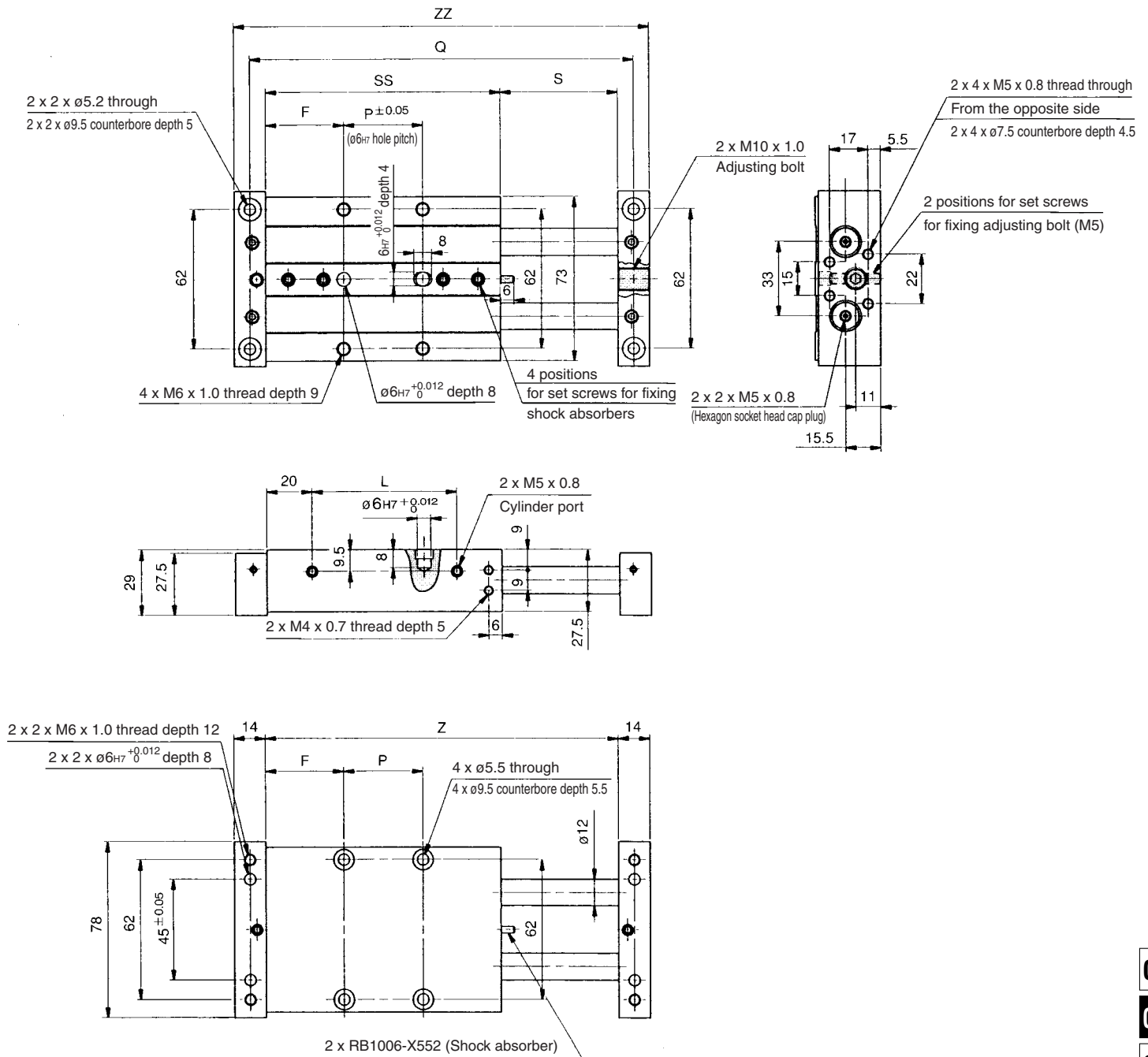

CX2

CXW

CXT

CXSJ

CXS

D-□

-X□

Individual
-X□

| Model | F | L | P | Q | S | SS | Z | ZZ (mm) |
|------------|------|-----|----|-----|-----|-----|-----|---------|
| CXWM20-50 | 34.5 | 64 | 35 | 170 | 52 | 104 | 156 | 184 |
| CXWM20-75 | 34.5 | 89 | 60 | 220 | 77 | 129 | 206 | 234 |
| CXWM20-100 | 39.5 | 114 | 75 | 270 | 102 | 154 | 256 | 284 |
| CXWM20-125 | 44.5 | 139 | 90 | 320 | 127 | 179 | 306 | 334 |
| CXWM20-150 | 57 | 164 | 90 | 370 | 152 | 204 | 356 | 384 |
| CXWM20-175 | 69.5 | 189 | 90 | 420 | 177 | 229 | 406 | 434 |
| CXWM20-200 | 82 | 214 | 90 | 470 | 202 | 254 | 456 | 484 |

Note) For 25 stroke, the shock absorber is mounted on a single side of the plate. For dimensions of 25 stroke, refer to page 488.

Series CXWM

ø20 Basic Type: CXWM20-25 stroke

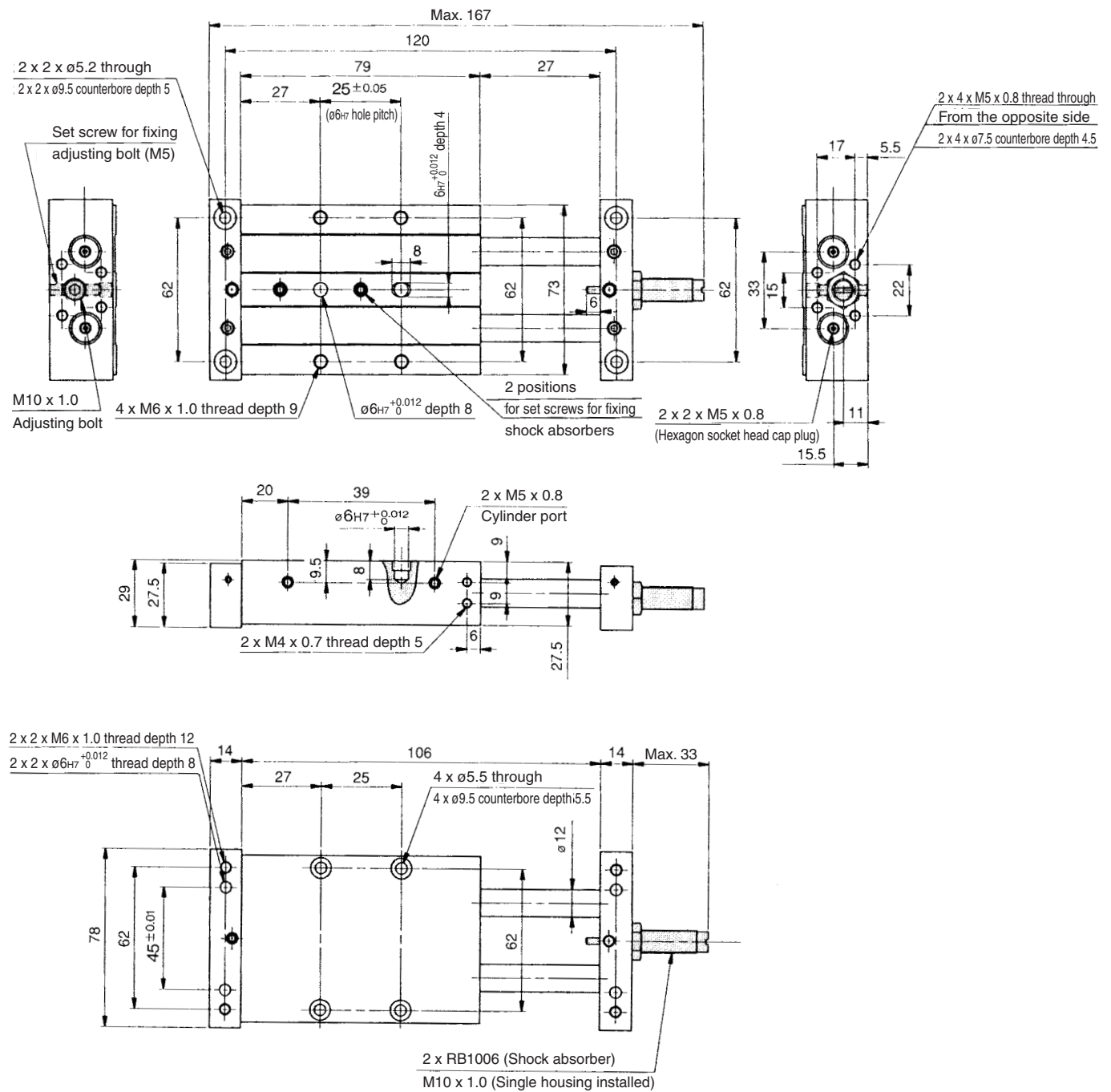

ø20 With End Lock: CXWM20-Stroke/50 to 200 R

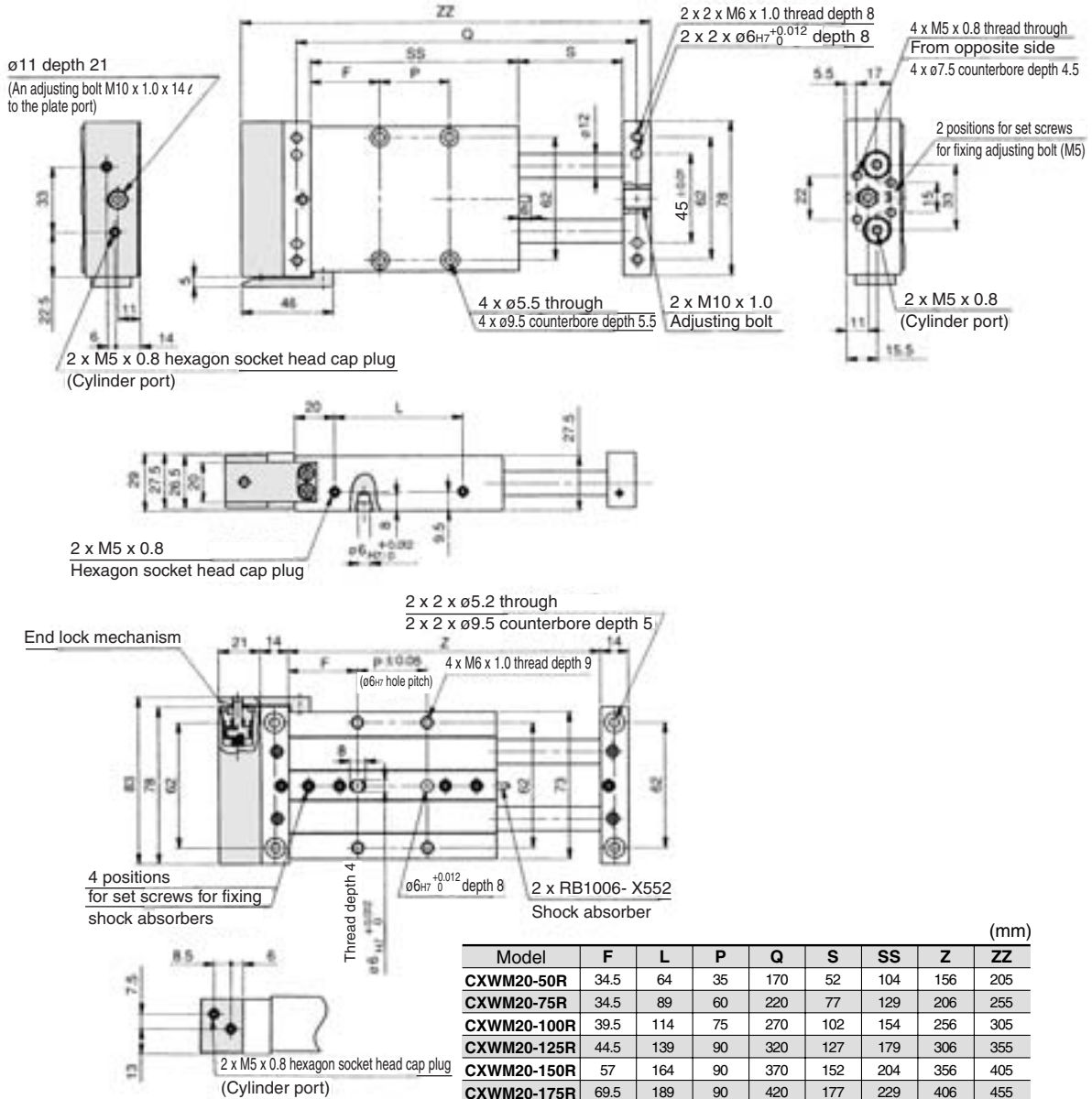

| Model | F | L | P | Q | S | SS | Z | ZZ |
|-------------|------|-----|----|-----|-----|-----|-----|-----|
| CXWM20-50R | 34.5 | 64 | 35 | 170 | 52 | 104 | 156 | 205 |
| CXWM20-75R | 34.5 | 89 | 60 | 220 | 77 | 129 | 206 | 255 |
| CXWM20-100R | 39.5 | 114 | 75 | 270 | 102 | 154 | 256 | 305 |
| CXWM20-125R | 44.5 | 139 | 90 | 320 | 127 | 179 | 306 | 355 |
| CXWM20-150R | 57 | 164 | 90 | 370 | 152 | 204 | 356 | 405 |
| CXWM20-175R | 69.5 | 189 | 90 | 420 | 177 | 229 | 406 | 455 |
| CXWM20-200R | 82 | 214 | 90 | 470 | 202 | 254 | 456 | 505 |

Housing mounting style with auto switch
CDBXWM20-Stroke , CDBXWM20-Stroke R

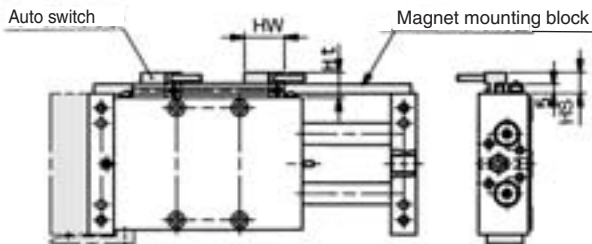

Note 1) The dimensions show D-A7 and D-A8. (mm)

| Auto switch model | Hw | Hs | Ht |
|--|----|------|------|
| D-A7□, D-A80 | 23 | 12.5 | 15 |
| D-F7□, D-J79, D-J79W, D-F7□W, D-F79F, D-F7BAL, D-F7NTL | 23 | 12.5 | 15 |
| D-A7□H, D-A80H | 22 | 12.5 | 15 |
| D-A73C, D-A80C | 23 | 15 | 17.5 |
| D-F7□V, D-F7□WV, D-F7BAV | 23 | 12.5 | 15 |
| D-J79C | 24 | 15 | 17.5 |
| D-F7LF | 30 | 12.5 | 15 |

Note 2) For 25 stroke, the shock absorber is mounted on a single side of the plate. For dimensions of 25 stroke, refer to page 490.

Plate mounting style with auto switch
CDPXWM20-Stroke , CDPXWM20-Stroke R

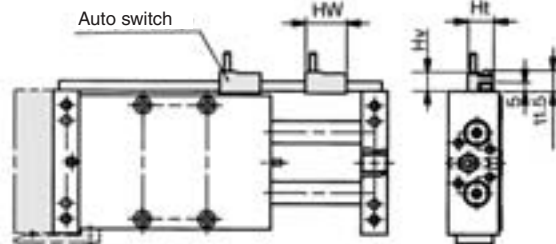

Note 1) The dimensions show D-A7 and D-A8. (mm)

| Auto switch model | Hw | Ht | Hv |
|--|----|------|------|
| D-A7□, D-A80 | 23 | 15 | 10.5 |
| D-F7□, D-J79, D-J79W, D-F7□W, D-F79F, D-F7BAL, D-F7NTL | 23 | 15 | 10 |
| D-A7□H, D-A80H | 22 | 15 | 9 |
| D-A73C, D-A80C | 23 | 17.5 | 17.5 |
| D-F7□V, D-F7□WV, D-F7BAV | 23 | 15 | 14 |
| D-J79C | 24 | 17.5 | 16 |

Note 2) For 25 stroke, the shock absorber is mounted on a single side of the plate. For dimensions of 25 stroke, refer to page 490.

CX2

CXW

CXT

CXSJ

CXS

D-□

-X□

Individual

-X□

Series CXWM

ø20 With End Lock: CXWM20-25 stroke R

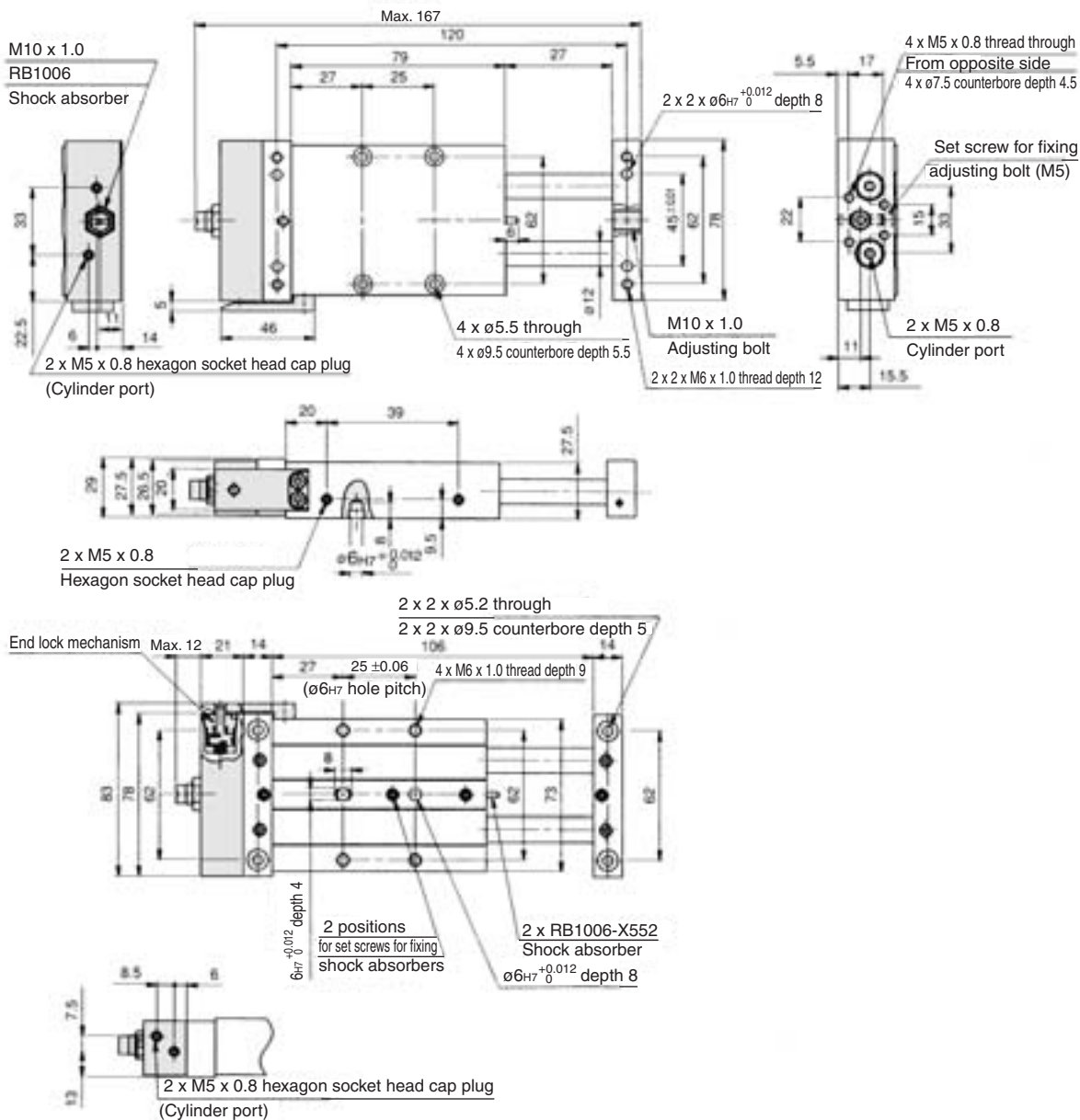

Housing mounting style with auto switch CDBXWM20-25, CDBXWM20-25R

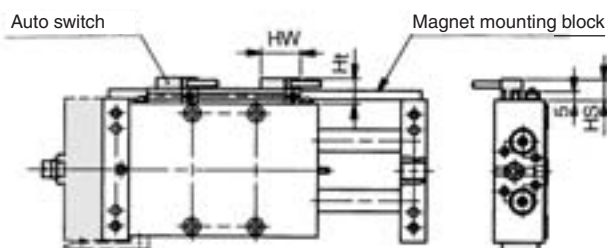

Note 1) The dimensions show D-A7 and D-A8. (mm)

| Auto switch model | Hw | Hs | Ht |
|--|----|------|------|
| D-A7□, D-A80 | 23 | 12.5 | 15 |
| D-F7□, D-J79, D-J79W, D-F7□W, D-F79F, D-F7BAL, D-F7NTL | 23 | 12.5 | 15 |
| D-A7□H, D-A80H | 22 | 12.5 | 15 |
| D-A73C, D-A80C | 23 | 15 | 17.5 |
| D-F7□V, D-F7□WV, D-F7BAV | 23 | 12.5 | 15 |
| D-J79C | 24 | 15 | 17.5 |
| D-F7LF | 30 | 12.5 | 15 |

Note 2) 2 magnets for auto switches are equipped to the magnet mounting block.

Plate mounting style with auto switch CDPXWM20-25, CDPXWM20-25R

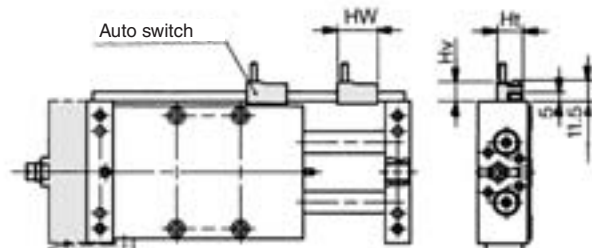

Note 1) The dimensions show D-A7 and D-A8. (mm)

| Auto switch model | Hw | Ht | Hv |
|--|----|------|------|
| D-A7□, D-A80 | 23 | 15 | 10.5 |
| D-F7□, D-J79, D-J79W, D-F7□W, D-F79F, D-F7BAL, D-F7NTL | 23 | 15 | 10 |
| D-A7□H, D-A80H | 22 | 15 | 9 |
| D-A73C, D-A80C | 23 | 17.5 | 17.5 |
| D-F7□V, D-F7□WV, D-F7BAV | 23 | 15 | 14 |
| D-J79C | 24 | 17.5 | 16 |

Note 2) 2 magnets for auto switches are installed in the housing.

Slide Unit: Built-in Shock Absorber Slide Bearing Type **Series CXWM**

ø25 Basic Type: CXWM25-Stroke/50 to 200

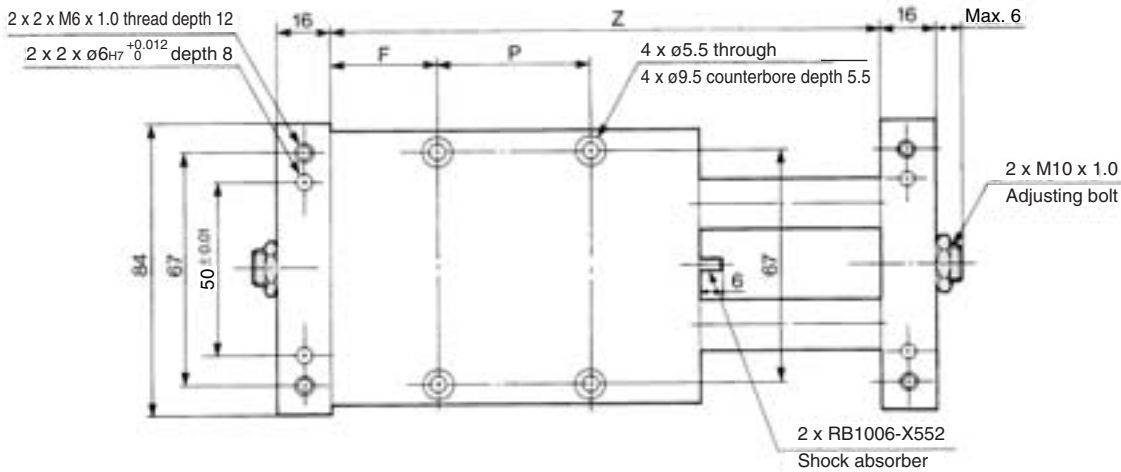
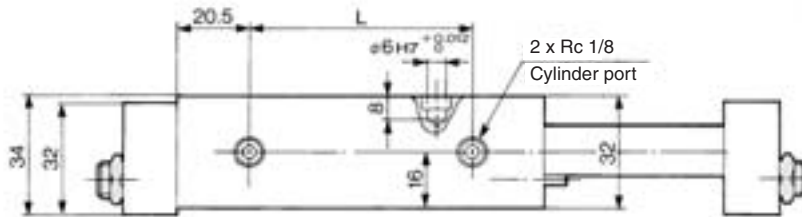
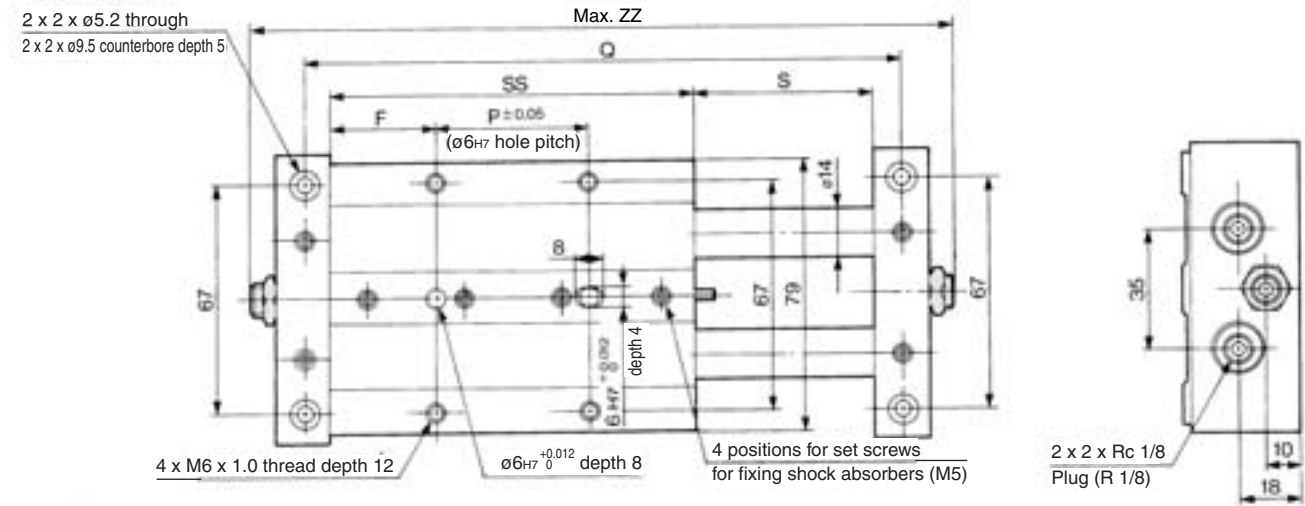

Note) For 25 stroke, the shock absorber is mounted on a plate.
For dimensions of 25 stroke, refer to page 492.

| Model | F | L | P | Q | S | SS | Z | ZZ |
|------------|------|-----|----|-----|-----|-----|-----|-----|
| CXWM25-50 | 31 | 66 | 45 | 175 | 52 | 107 | 159 | 203 |
| CXWM25-75 | 33.5 | 91 | 65 | 225 | 77 | 132 | 209 | 253 |
| CXWM25-100 | 33.5 | 116 | 90 | 275 | 102 | 157 | 259 | 303 |
| CXWM25-125 | 46 | 141 | 90 | 325 | 127 | 182 | 309 | 353 |
| CXWM25-150 | 58.5 | 166 | 90 | 375 | 152 | 207 | 359 | 403 |
| CXWM25-175 | 71 | 191 | 90 | 425 | 177 | 232 | 409 | 453 |
| CXWM25-200 | 83.5 | 216 | 90 | 475 | 202 | 257 | 459 | 503 |

(mm)

CX2

CXW

CXT

CXSJ

CXS

D-□

-X□

Individual
-X□

Series CXWM

ø25 Basic Type: CXWM25-25 stroke

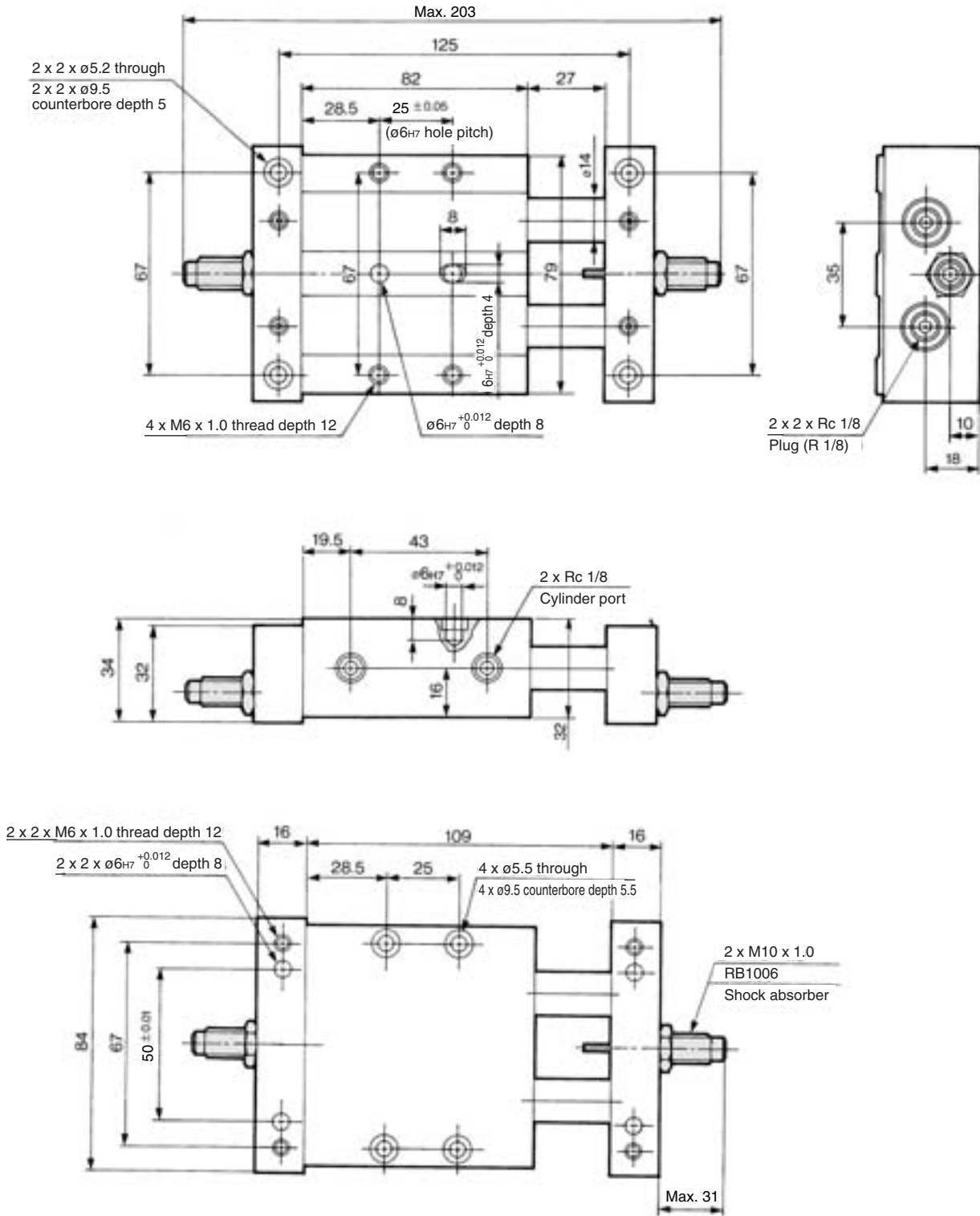

ø25 With End Lock: CXWM25-Stroke/50 to 200 R

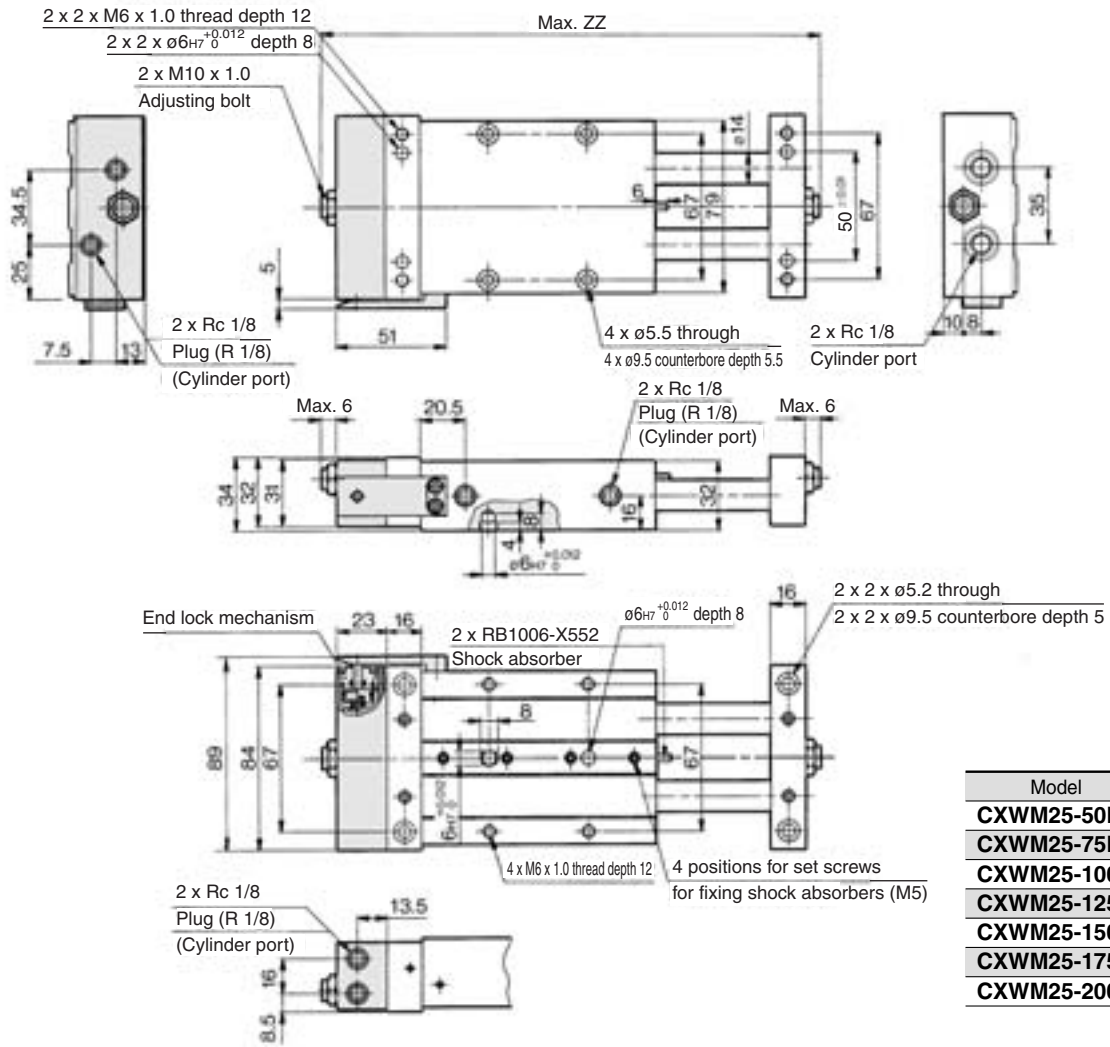

| Model | ZZ (mm) |
|-------------|---------|
| CXWM25-50R | 226 |
| CXWM25-75R | 276 |
| CXWM25-100R | 326 |
| CXWM25-125R | 376 |
| CXWM25-150R | 426 |
| CXWM25-175R | 476 |
| CXWM25-200R | 526 |

Housing mounting style with auto switch
CDBXWM25-Stroke, CDBXWM25-Stroke R

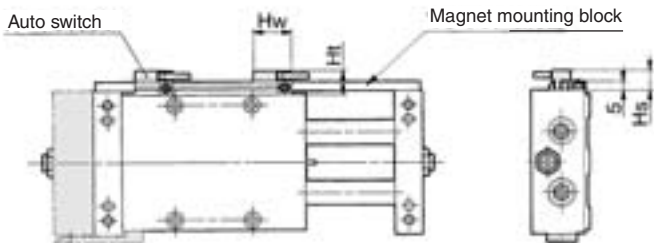

Note 1) The dimensions show D-A7 and D-A8. (mm)

| Auto switch model | Hw | Hs | Ht |
|--|----|------|------|
| D-A7□, D-A80 | 23 | 12.5 | 15 |
| D-F7□, D-J79, D-J79W, D-F7□W, D-F79F, D-F7BAL, D-F7NTL | 23 | 12.5 | 15 |
| D-A7□H, D-A80H | 22 | 12.5 | 15 |
| D-A73C, D-A80C | 23 | 15 | 17.5 |
| D-F7□V, D-F7□WV, D-F7BAV | 23 | 12.5 | 15 |
| D-J79C | 24 | 15 | 17.5 |
| D-F7LF | 30 | 12.5 | 15 |

Note 2) For 25 stroke, the shock absorber is mounted on a single side of the plate. For dimensions of 25 stroke, refer to page 494.

Plate mounting style with auto switch
CDPXWM25-Stroke, CDPXWM25-Stroke R

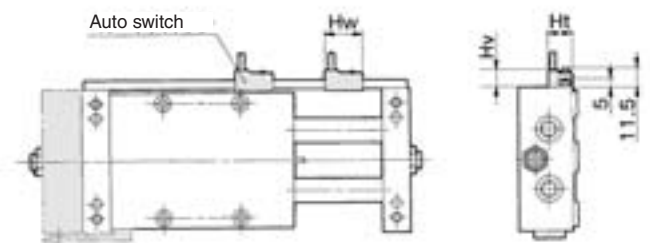

Note 1) The dimensions show D-A7 and D-A8. (mm)

| Auto switch model | Hw | Ht | Hv |
|--|----|------|------|
| D-A7□, D-A80 | 23 | 15 | 10.5 |
| D-F7□, D-J79, D-J79W, D-F7□W, D-F79F, D-F7BAL, D-F7NTL | 23 | 15 | 10 |
| D-A7□H, D-A80H | 22 | 15 | 9 |
| D-A73C, D-A80C | 23 | 17.5 | 17.5 |
| D-F7□V, D-F7□WV, D-F7BAV | 23 | 15 | 14 |
| D-J79C | 24 | 17.5 | 16 |

Note 2) For 25 stroke, the shock absorber is mounted on a single side of the plate. For dimensions of 25 stroke, refer to page 494.

CX2

CXW

CXT

CXSJ

CXS

D-□

-X□

Individual
-X□

Series CXWM

ø25 With End Lock: CXWM25-25 stroke R

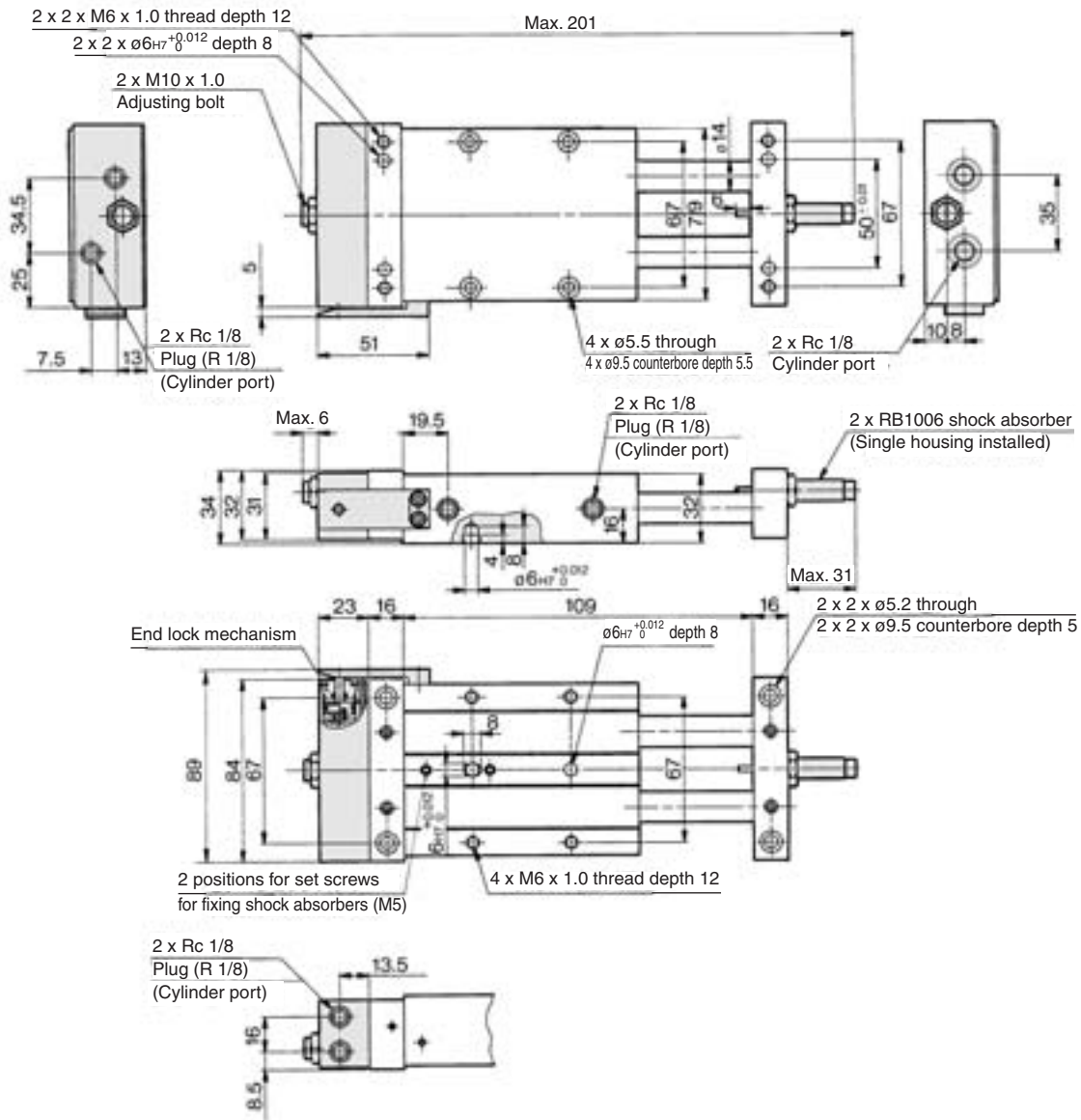

Housing mounting style with auto switch CDBXWM25-25, CDBXWM25-25R

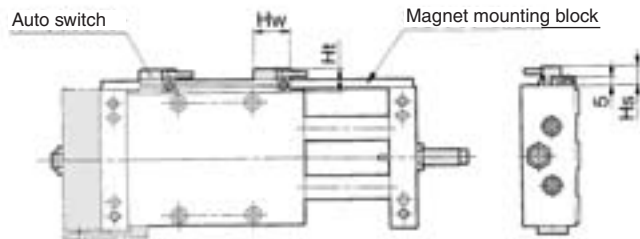

Note 1) The dimensions show D-A7 and D-A8. (mm)

| Auto switch model | Hw | Hs | Ht |
|--|----|------|------|
| D-A7□, D-A80 | 23 | 12.5 | 15 |
| D-F7□, D-J79, D-J79W, D-F7□W, D-F79F, D-F7BAL, D-F7NTL | 23 | 12.5 | 15 |
| D-A7□H, D-A80H | 22 | 12.5 | 15 |
| D-A73C, D-A80C | 23 | 15 | 17.5 |
| D-F7□V, D-F7□WV, D-F7BAV | 23 | 12.5 | 15 |
| D-J79C | 24 | 15 | 17.5 |
| D-F7LF | 30 | 12.5 | 15 |

Note 2) 2 magnets for auto switches are equipped to the magnet mounting block.

Plate mounting style with auto switch CDPXWM25-25, CDPXWM25-25R

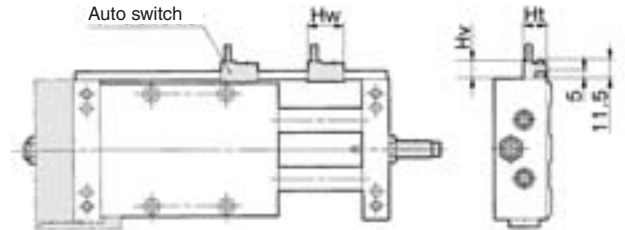

Note 1) The dimensions show D-A7 and D-A8. (mm)

| Auto switch model | Hw | Ht | Hv |
|--|----|------|------|
| D-A7□, D-A80 | 23 | 15 | 10.5 |
| D-F7□, D-J79, D-J79W, D-F7□W, D-F79F, D-F7BAL, D-F7NTL | 23 | 15 | 10 |
| D-A7□H, D-A80H | 22 | 15 | 9 |
| D-A73C, D-A80C | 23 | 17.5 | 17.5 |
| D-F7□V, D-F7□WV, D-F7BAV | 23 | 15 | 14 |
| D-J79C | 24 | 17.5 | 16 |

Note 2) 2 magnets for auto switches are installed in the housing.

Slide Unit: Built-in Shock Absorber Slide Bearing Type **Series CXWM**

ø32 Basic Type: CXWM32-Stroke/75 to 200

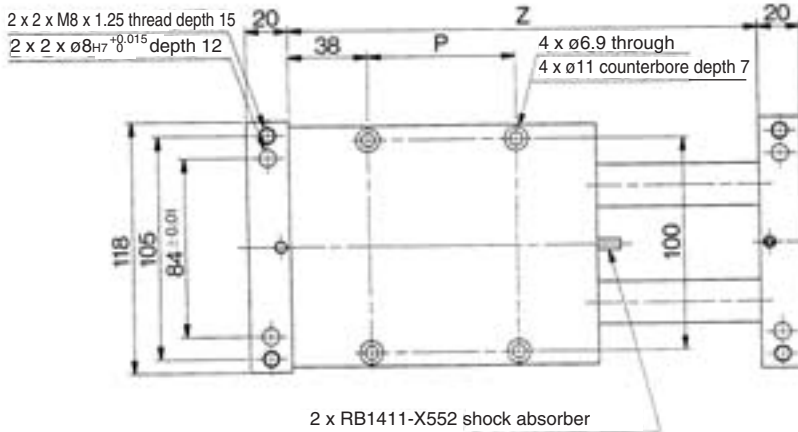
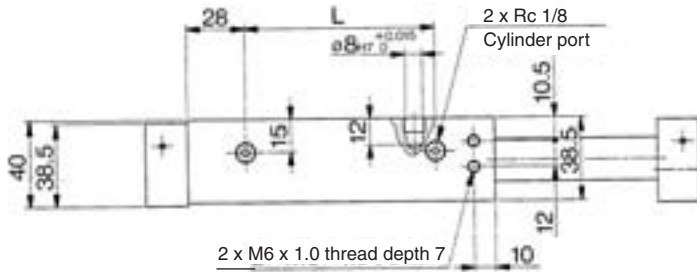
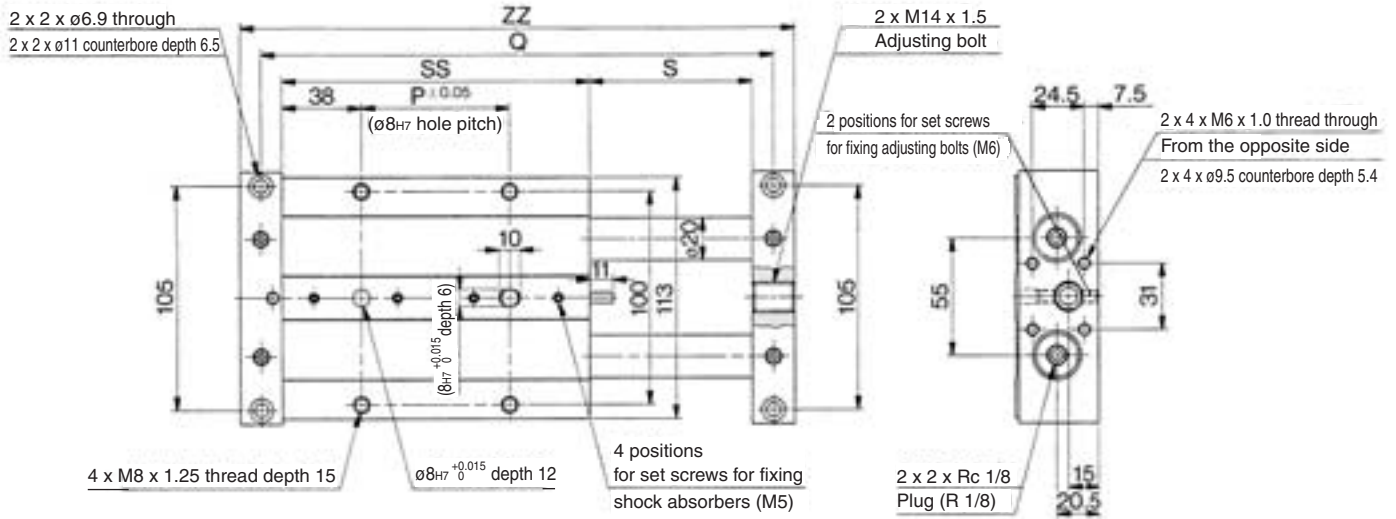

(mm)

| Model | L | P | Q | S | SS | Z | ZZ |
|-------------------|-----|-----|-----|-----|-----|-----|-----|
| CXWM32-75 | 90 | 70 | 243 | 77 | 146 | 223 | 263 |
| CXWM32-100 | 115 | 95 | 293 | 102 | 171 | 273 | 313 |
| CXWM32-125 | 140 | 120 | 343 | 127 | 196 | 323 | 363 |
| CXWM32-150 | 165 | 145 | 393 | 152 | 221 | 373 | 413 |
| CXWM32-175 | 190 | 170 | 443 | 177 | 246 | 423 | 463 |
| CXWM32-200 | 215 | 195 | 493 | 202 | 271 | 473 | 513 |

Note) For 25 and 50 strokes, the shock absorber is mounted on a single side of the plate. For dimensions of 25 and 50 strokes, refer to page 496.

CX2

CXW

CXT

CXSJ

CXS

D-□

-X□

**Individual
-X□**

Series CXWM

ø32 Basic Type: CXWM32-Stroke/25, 50

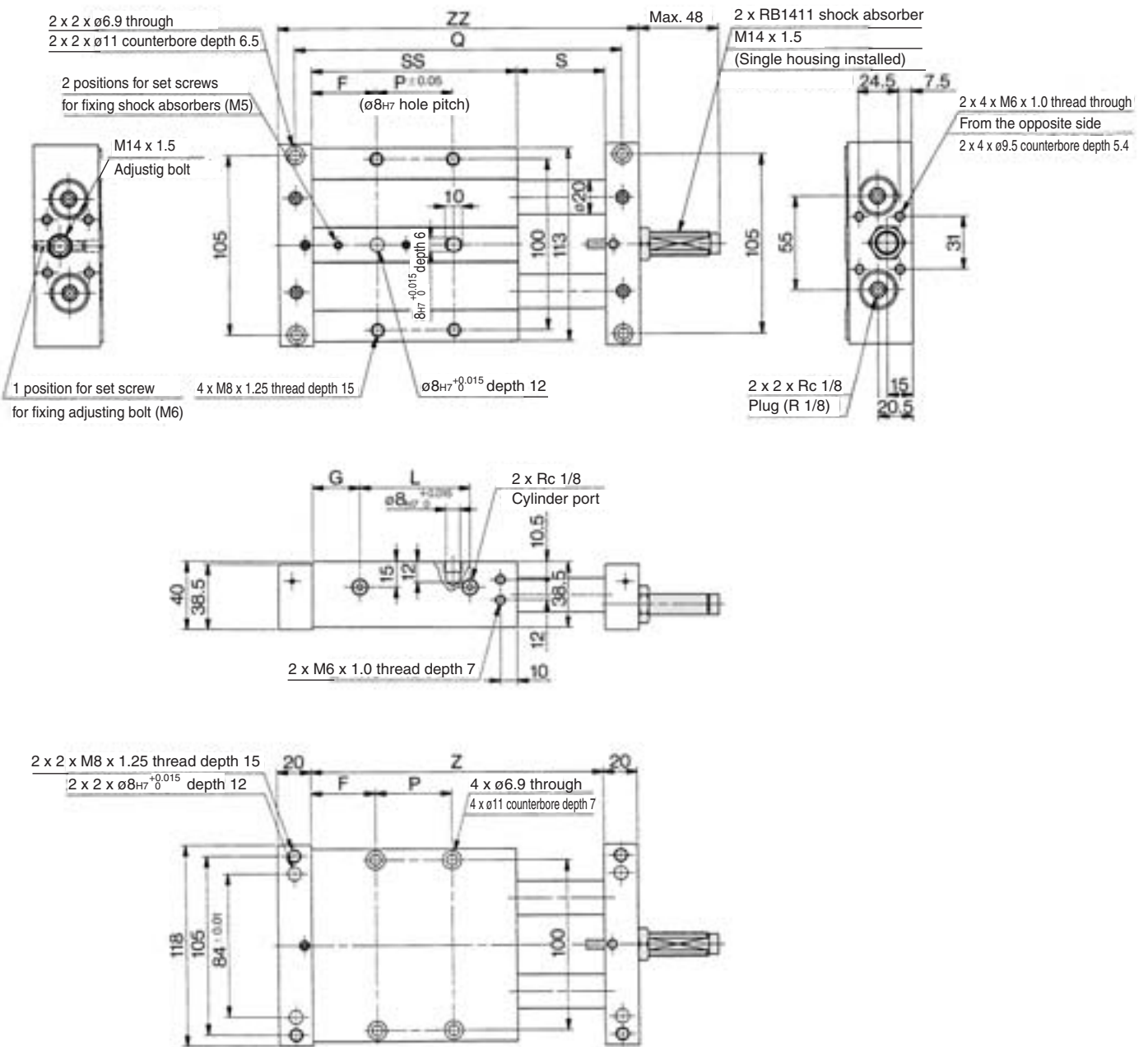

(mm)

| Model | F | L | P | Q | S | SS | G | Z | ZZ |
|-----------|----|----|----|-----|----|-----|------|-----|-----|
| CXWM32-25 | 37 | 41 | 22 | 143 | 27 | 96 | 27.5 | 123 | 163 |
| CXWM32-50 | 38 | 65 | 45 | 193 | 52 | 121 | 28 | 173 | 213 |

ø32 With End Lock: CXWM32-Stroke/75 to 200 R

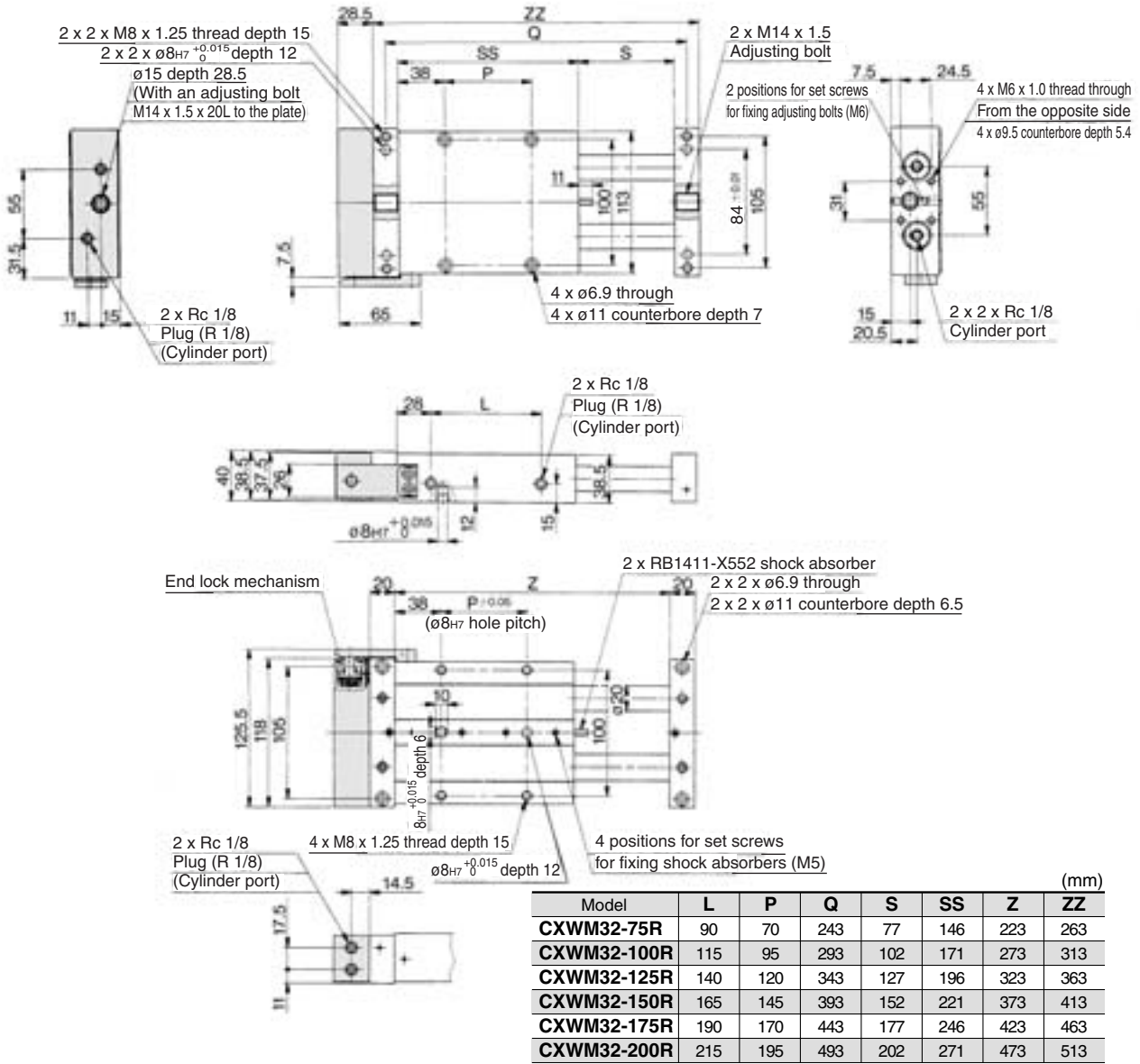

| Model | L | P | Q | S | SS | Z | ZZ |
|--------------------|-----|-----|-----|-----|-----|-----|-----|
| CXWM32-75R | 90 | 70 | 243 | 77 | 146 | 223 | 263 |
| CXWM32-100R | 115 | 95 | 293 | 102 | 171 | 273 | 313 |
| CXWM32-125R | 140 | 120 | 343 | 127 | 196 | 323 | 363 |
| CXWM32-150R | 165 | 145 | 393 | 152 | 221 | 373 | 413 |
| CXWM32-175R | 190 | 170 | 443 | 177 | 246 | 423 | 463 |
| CXWM32-200R | 215 | 195 | 493 | 202 | 271 | 473 | 513 |

Housing mounting style with auto switch
CDBXWM32-Stroke, CDBXWM32-Stroke R

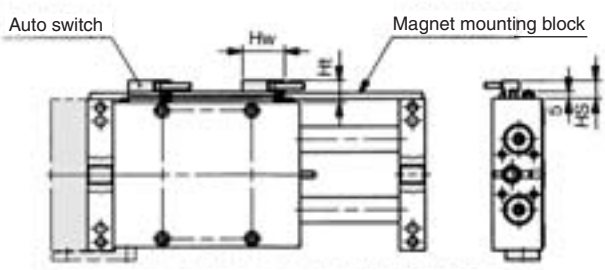

Note 1) The dimensions show D-A7 and D-A8. (mm)

| Auto switch model | Hw | Hs | Ht |
|---|----|------|------|
| D-A7□, D-A80 | 23 | 12.5 | 15 |
| D-F7□, D-J79, D-J79W, D-F7□W, D-F79F, D-F7BAL, D-F7NTL | 23 | 12.5 | 15 |
| D-A7□H, D-A80H | 22 | 12.5 | 15 |
| D-A73C, D-A80C | 23 | 15 | 17.5 |
| D-F7□V, D-F7□WV, D-F7BAV | 23 | 12.5 | 15 |
| D-J79C | 24 | 15 | 17.5 |
| D-F7LF | 30 | 12.5 | 15 |

Note 2) For 25 and 50 stroke, the shock absorber is mounted on a single side of the plate. For dimensions of 25 and 50 strokes, refer to page 498.

Plate mounting style with auto switch
CDPXWM32-Stroke, CDPXWM32-Stroke R

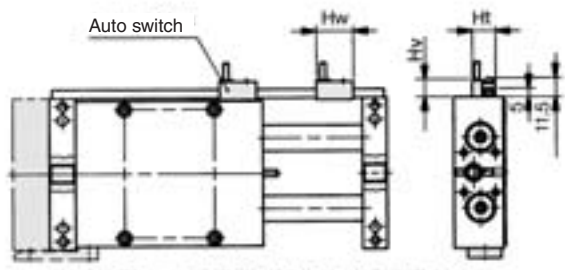

Note 1) The dimensions show D-A7 and D-A8. (mm)

| Auto switch model | Hw | Ht | Hv |
|---|----|------|------|
| D-A7□, D-A80 | 23 | 15 | 10.5 |
| D-F7□, D-J79, D-J79W, D-F7□W, D-F79F, D-F7BAL, D-F7NTL | 23 | 15 | 10 |
| D-A7□H, D-A80H | 22 | 15 | 9 |
| D-A73C, D-A80C | 23 | 17.5 | 17.5 |
| D-F7□V, D-F7□WV, D-F7BAV | 23 | 15 | 14 |
| D-J79C | 24 | 17.5 | 16 |

Note 2) For 25 and 50 stroke, the shock absorber is mounted on a single side of the plate. For dimensions of 25 and 50 strokes, refer to page 498.

- CX2**
- CXW**
- CXT**
- CXSJ**
- CXS**

- D-□**
- X□**
- Individual -X□**

Series CXWM

ø32 With End Lock: CXWM32-Stroke/25, 50 R

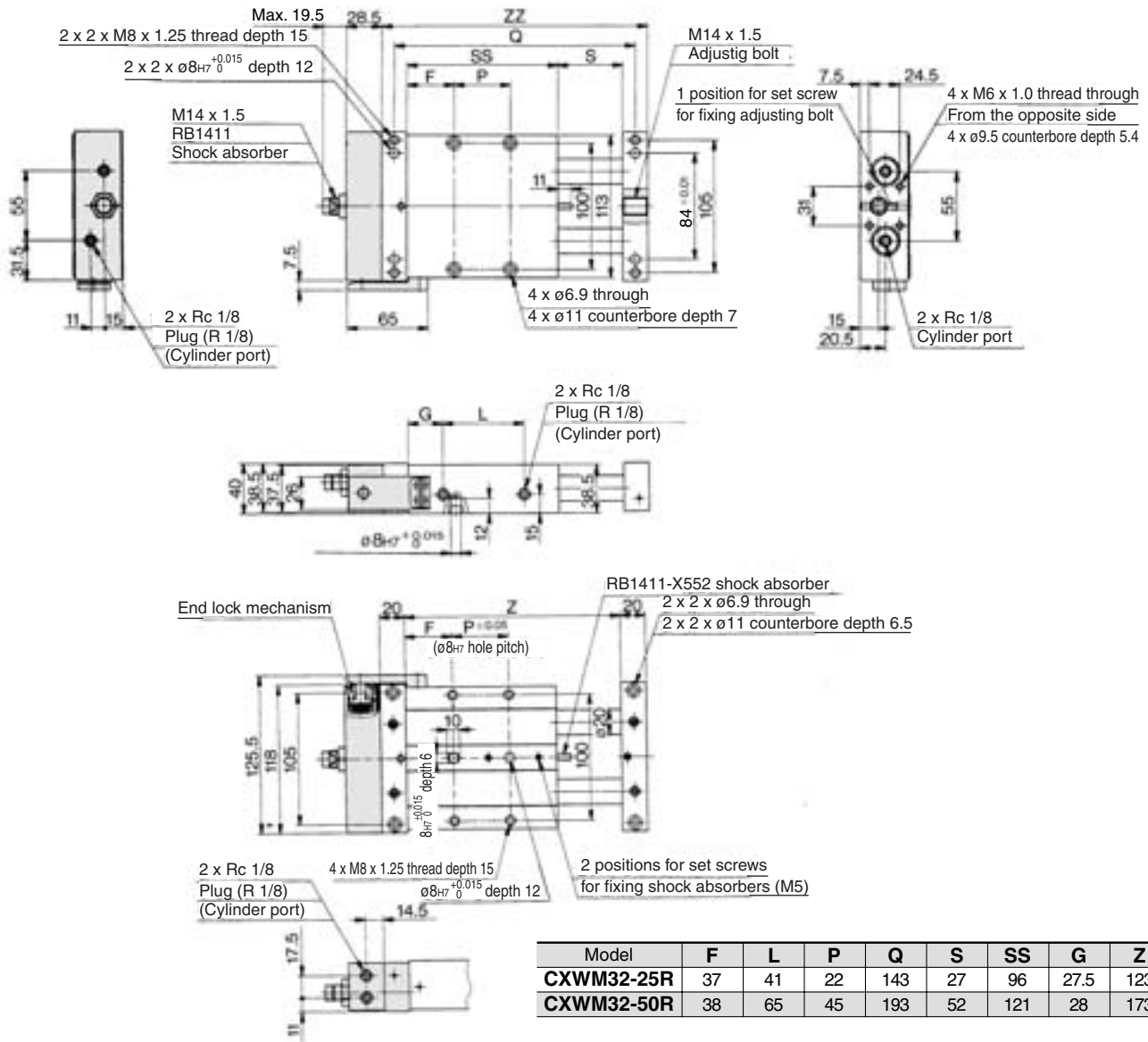

Housing mounting style with auto switch CDBXWM32-25/50, CDBXWM32-25R/50R

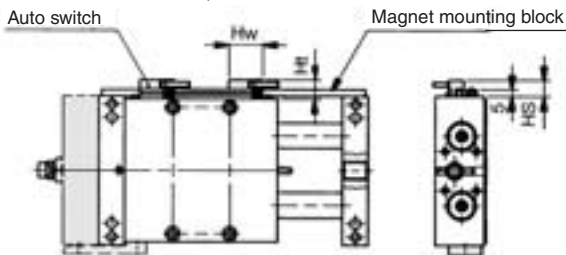

Note 1) The dimensions show D-A7 and D-A8. (mm)

| Auto switch model | Hw | Hs | Ht |
|--|----|------|------|
| D-A7□, D-A80 | 23 | 12.5 | 15 |
| D-F7□, D-J79, D-J79W, D-F7□W, D-F79F, D-F7BAL, D-F7NTL | 23 | 12.5 | 15 |
| D-A7□H, D-A80H | 22 | 12.5 | 15 |
| D-A73C, D-A80C | 23 | 15 | 17.5 |
| D-F7□V, D-F7□WV, D-F7BAV | 23 | 12.5 | 15 |
| D-J79C | 24 | 15 | 17.5 |
| D-F7LF | 30 | 12.5 | 15 |

Note 2) For 25 stroke, 2 magnets for auto switches are equipped to the magnet mounting block.

Plate mounting style with auto switch CDPXWM32-25/50, CDPXWM32-25R/50R

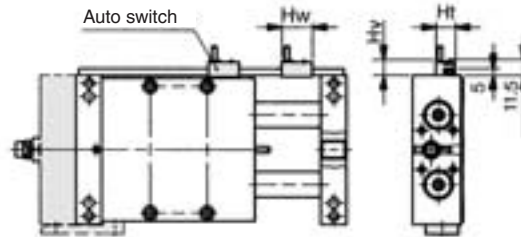

Note 1) The dimensions show D-A7 and D-A8. (mm)

| Auto switch model | Hw | Ht | Hv |
|--|----|------|------|
| D-A7□, D-A80 | 23 | 15 | 10.5 |
| D-F7□, D-J79, D-J79W, D-F7□W, D-F79F, D-F7BAL, D-F7NTL | 23 | 15 | 10 |
| D-A7□H, D-A80H | 22 | 15 | 9 |
| D-A73C, D-A80C | 23 | 17.5 | 17.5 |
| D-F7□V, D-F7□WV, D-F7BAV | 23 | 15 | 14 |
| D-J79C | 24 | 17.5 | 16 |

Note 2) For 25 stroke, 2 magnets for auto switches are installed in the housing.

Slide Unit: Built-in Shock Absorber Ball Bushing Bearing Type Series CXWL

ø10, ø16, ø20, ø25, ø32

How to Order

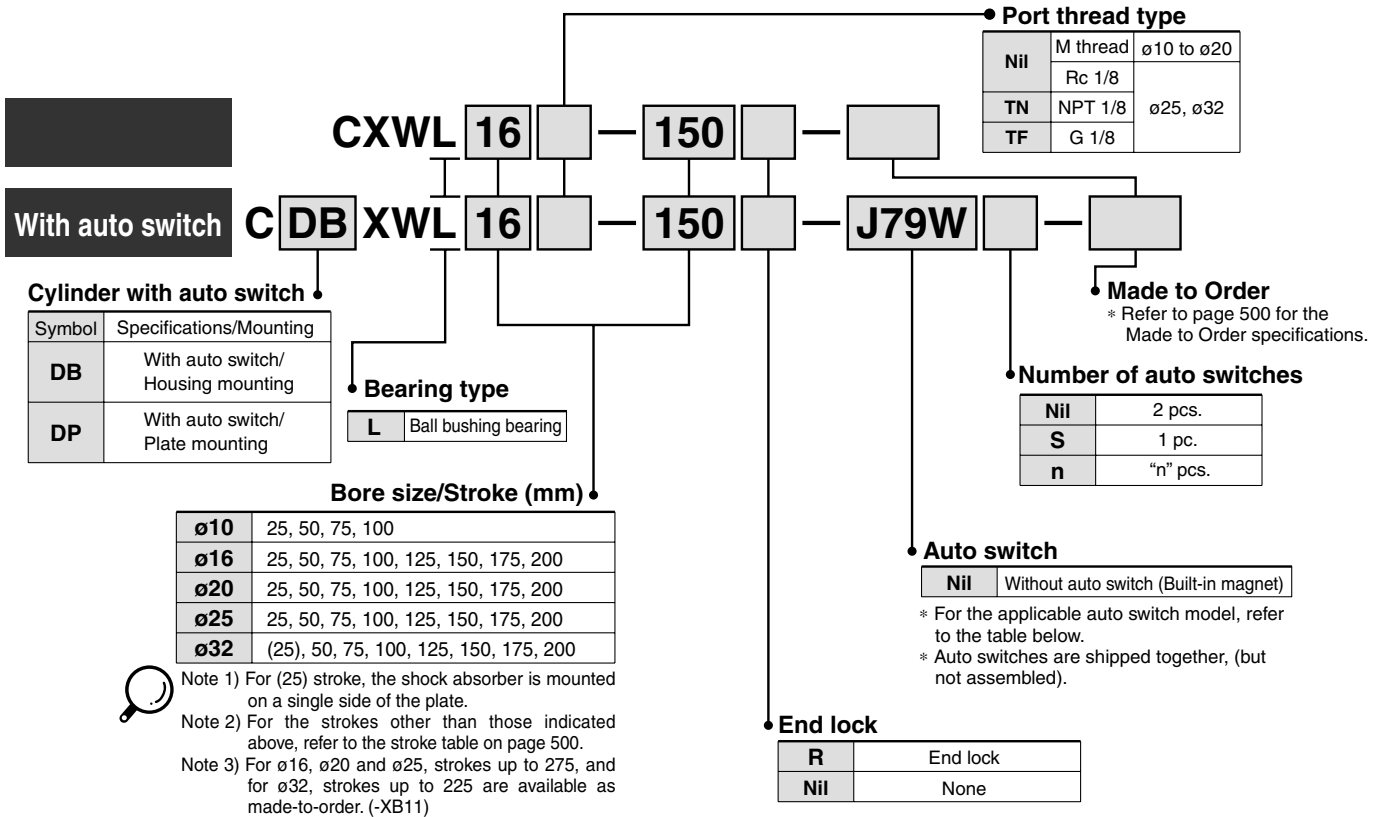

Applicable Auto Switch/Refer to pages 1719 to 1827 for further information on auto switches.

| Type | Special function | Electrical entry | Indicator light | Wiring (Output) | Load voltage | | Rail mounting | | Applicable cylinder size | | Lead wire length (m)* | | | | Pre-wired connector | Applicable load | | | | | | |
|--------------------|--|--------------------------------------|-----------------|-------------------------|--------------|-------------------------|-------------------------|---------|--------------------------|---------------------------------|-----------------------|-----------|--------------|----------|---------------------|-----------------|------------|------------|------|---|---|---|
| | | | | | DC | AC | Perpendicular | In-line | Housing mounting | Plate mounting | 0.5 (Nil) | 3 (L) | 5 (Z) | None (N) | | IC circuit | Relay, PLC | | | | | |
| Solid state switch | - | Grommet | Yes | 3-wire (NPN) | 5 V, 12 V | - | F7NV | F79 | ø16 ø20 ø25 ø32 | ø10 ø16 ø20 ø25 ø32 | ● | ● | ○ | - | ○ | | | IC circuit | - | | | |
| | | | | 3-wire (PNP) | | | F7BV | F7P | | | ● | ● | ○ | - | ○ | | | | | | | |
| | | 2-wire | | F7PV | J79 | ● | ● | ○ | | | - | ○ | - | | | | | | | | | |
| | | 3-wire (NPN) | | F7NWV | F79W | ● | ● | ○ | | | - | ○ | | | | | | | | | | |
| | Diagnostic indication (2-color indication) | Grommet | Yes | 3-wire (PNP) | 5 V, 12 V | - | - | F7PW | | | ● | ● | ○ | - | ○ | IC circuit | - | | | | | |
| | | | | 2-wire | | | F7BWV | J79W | | | ● | ● | ○ | - | ○ | | | | | | | |
| | | Water resistant (2-color indication) | | Grommet | No | 4-wire (NPN) | 5 V, 12 V | - | | | - | F79F | ● | ● | ○ | - | ○ | IC circuit | - | | | |
| | | | | | | 3-wire (NPN equivalent) | | | | | - | A76H | ● | ● | - | - | - | | | | | |
| Reed switch | - | Grommet | Yes | 3-wire (NPN equivalent) | 5 V | - | A72 | A72H | ø16 ø20 ø25 ø32 | ø10 ø16 ø20 ø25 ø32 | ● | ● | - | - | - | - | - | | | | | |
| | | | | | | | 2-wire | 24 V | | | 5 V, 12 V | 100 V | A73 | A73H | ● | | | ● | - | - | - | |
| | | | | Connector | No | Yes | 2-wire | 12 V | | | - | A73C | - | ● | ● | ● | ● | - | - | - | - | |
| | | | | | | | | | | | | 5 V, 12 V | 24 V or less | A80C | - | ● | ● | ● | ● | | | - |
| | | | | Grommet | No | Yes | 3-wire (NPN equivalent) | 5 V | | | - | - | E76A | ø10 | - | ● | ● | - | - | - | - | - |
| | | | | | | | | | | | | 2-wire | 24 V | | | 12 V | 100 V | - | E73A | ● | | |
| | | Grommet | No | No | 2-wire | 5 V, 12 V | 100 V or less | - | E80A | ● | ● | - | - | - | - | - | IC circuit | - | | | | |
| | | | | | | | | 24 V | 5 V, 12 V | 100 V or less | - | E80A | ● | ● | - | - | | | - | | | |

* Lead wire length symbols: 0.5 m Nil (Example) F79W
 3 m L (Example) F79WL
 5 m Z (Example) F79WZ
 None N (Example) J79CW

* Solid state auto switches marked with "○" are produced upon receipt of order.
 ** It is impossible to mount solid state switches to the housing mounting ø10.

- Since there are other applicable auto switches than listed, refer to page 517 for details.
- For details about auto switches with pre-wired connector, refer to pages 1784 and 1785.

Series CXWL

Built-in shock absorber

This is built-in shock absorber style in which the shock absorber is enclosed in the housing.

Dramatically reduced installation labor

The machining precision required for positioning during the installation of the cylinder has been reduced through the adoption of a special pin hole machining process, thus decreasing the amount of labor involved in adjustment.

High-precision ball bushing

The bearings made of ball bushings decrease the rise in starting pressure that could be caused by a load imbalance.

This also enables smooth operation by ensuring stable travel resistance.

Provided with an end lock mechanism

An end lock is also available, which maintains the cylinder's original position even if the air supply is interrupted.

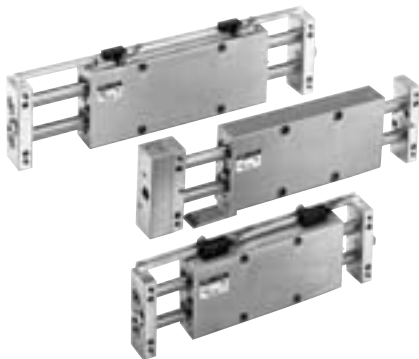

Made to Order Specifications
(For details, refer to pages 1851 to 2021.)

| Symbol | Specifications |
|--------|-----------------------------------|
| —XB11 | Long stroke type |
| —XB13 | Low speed cylinder (5 to 50 mm/s) |
| —XC22 | Fluororubber seal |
| —X146 | Hollow piston rod |
| —X138 | Adjustable stroke |
| —X168 | Helical insert thread |
| —X169 | 2 built-in magnets |

Standard Stroke

| Model | Standard stroke (mm) | | | | | | | |
|-----------|----------------------|----|----|-----|-----|-----|-----|-----|
| | 25 | 50 | 75 | 100 | 125 | 150 | 175 | 200 |
| CXWL10-□□ | ● | ● | ● | ● | — | — | — | — |
| CXWL16-□□ | ● | ● | ● | ● | ● | ● | ● | ● |
| CXWL20-□□ | ● | ● | ● | ● | ● | ● | ● | ● |
| CXWL25-□□ | ● | ● | ● | ● | ● | ● | ● | ● |
| CXWL32-□□ | (*) | ● | ● | ● | ● | ● | ● | ● |

Note) The strokes marked with “(*)” has an absorber of single side plate mounting style.

Specifications

| Type | Non-lube | |
|-----------------------------|--|----------|
| Fluid | Air | |
| Proof pressure | 1.5 MPa | |
| Max. operating pressure | 1.0 MPa | |
| Min. operating pressure | CXWL10/16 | 0.15 MPa |
| | CXWL20/25/32 | 0.10 MPa |
| Ambient & fluid temperature | -10 to 60°C (No freezing) | |
| Piston speed (Non-lube) | 30 to 500 mm/s | |
| Cushion | Shock absorber | |
| Stroke adjustable range | Standard stroke: ±2 mm | |
| Accessory (Option) | Straight knock pin (2 pcs.), Adjusting bolt* (-X138) | |

* “-X138” has a stroke adjustable range of -12.5 mm on one side.

Maximum Load Mass/Non-rotating Accuracy/Maximum Holding Force

| Model | CXWL10 | CXWL16 | CXWL20 | CXWL25 | CXWL32 |
|---|---------|---------|---------|---------|---------|
| Max. movable mass ⁽¹⁾ | 1 kg | 4 kg | 5 kg | 7 kg | 10 kg |
| Non-rotating accuracy ⁽²⁾ (Deflection of a piston rod is not included.) | ± 0.09° | ± 0.03° | ± 0.03° | ± 0.02° | ± 0.01° |
| Max. holding force (End lock model) | 39.2 N | 98.1 N | 147.1 N | 245.2 N | 392.3 N |

Note 1) Place the center of gravity of the load and center of the slide unit close during operation. If they are placed far apart from each other, please consult with SMC.

Note 2) The factors are obtained under the conditions of a 25 strokes plate is pushed out.

Shock Absorber Specifications

| Shock absorber ⁽¹⁾ | RB0805-X552 | RB1006-X552 | RB1411 RB1411-X552 | |
|---|--------------|--------------|-----------------------|-------|
| Applicable slide unit | CXWL10/16-□□ | CXWL20/25-□□ | CXWL32-□□ | |
| Maximum energy absorption (J) | 0.98 | 3.92 | 14.7 | |
| Stroke absorption (mm) | 5 | 6 | 11 | |
| Max. collision speed (m/sec) | 0.05 to 5 | | | |
| Max. operating frequency (cycle/min) ⁽²⁾ | 80 | 70 | 45 | |
| Max. allowable thrust (N) | 147 | 353 | 667 | |
| Ambient temperature range (°C) | -10 to 80 | | | |
| Spring force (N) | Extended | 1.96 | 4.22 | 6.86 |
| | Retracted | 3.83 | 6.18 | 15.30 |
| Mass (g) | 15 | 25 | 65 | |

Note 1) “-X552” is an exclusive shock absorber installed in the housing, and is the screw not attached specification of the outer part of the outer tube. “CXWL32-25” is mounted on a single side of the plate and of the screw attached specification.

Note 2) It denotes the values at the maximum energy absorption per one cycle. Therefore, the operating frequency can be increased according to the energy absorption.

* The shock absorber service life is different from that of the cylinder depending on the operating conditions. Refer to the Series RB Specific Product Precautions for the replacement period.

Theoretical Output

(N)

| Model | Rod size (mm) | Piston area (mm ²) | Operating pressure (MPa) | | | | | | | |
|-----------|---------------|--------------------------------|--------------------------|-----|-----|-----|-----|-----|-----|-----|
| | | | 0.2 | 0.3 | 0.4 | 0.5 | 0.6 | 0.7 | 0.8 | 0.9 |
| CXWL10-□□ | 6 | 101 | 20 | 30 | 40 | 51 | 61 | 71 | 81 | 91 |
| CXWL16-□□ | 10 | 245 | 49 | 74 | 98 | 123 | 147 | 172 | 196 | 221 |
| CXWL20-□□ | 12 | 402 | 80 | 121 | 161 | 201 | 241 | 281 | 322 | 362 |
| CXWL25-□□ | 14 | 597 | 119 | 179 | 239 | 299 | 358 | 418 | 478 | 537 |
| CXWL32-□□ | 20 | 980 | 196 | 294 | 392 | 490 | 588 | 686 | 784 | 882 |

Note) Theoretical output (N) = Pressure (MPa) x Piston area (mm²)

Mass

(kg)

| Model | Stroke (mm) | | | | | | | |
|---------------|-------------|------|------|------|------|------|------|------|
| | 25 | 50 | 75 | 100 | 125 | 150 | 175 | 200 |
| CXWL10 | 0.33 | 0.40 | 0.46 | 0.53 | – | – | – | – |
| CXWL16 | 0.72 | 0.85 | 0.98 | 1.11 | 1.23 | 1.36 | 1.49 | 1.62 |
| CXWL20 | 1.0 | 1.18 | 1.35 | 1.53 | 1.71 | 1.89 | 2.06 | 2.24 |
| CXWL25 | 1.32 | 1.54 | 1.76 | 1.97 | 2.19 | 2.43 | 2.63 | 2.86 |
| CXWL32 | 2.56 | 2.96 | 3.37 | 3.75 | 4.19 | 4.56 | 4.98 | 5.39 |

Additional Mass with End Lock (CXWL□-R)

(kg)

| Applicable model | Additional mass |
|------------------|-----------------|
| CXWL10 | 0.08 |
| CXWL16 | 0.14 |
| CXWL20 | 0.15 |
| CXWL25 | 0.20 |
| CXWL32 | 0.43 |

**Accessory
Straight Knock Pin (Option)**

Operating Direction with Different Pressure Ports

Operating direction of housing when the plate is fixed

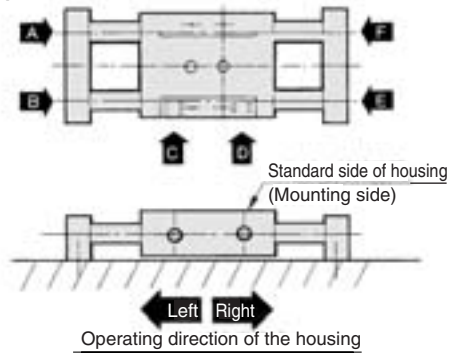

| Pressure port | A | B | C | D | E | F |
|---------------------|-------|------|------|-------|------|-------|
| Operating direction | Right | Left | Left | Right | Left | Right |

* There are 9 possible reciprocating piping methods.

With end lock (CXWL-□R)
Operating direction of housing when the plate is fixed

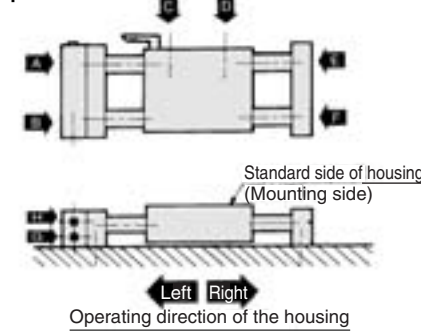

| Pressure port | A | B | C | D | E | F | G | H |
|---------------------|-------|------|------|-------|-------|------|------|-------|
| Operating direction | Right | Left | Left | Right | Right | Left | Left | Right |

* There are 16 possible reciprocating piping methods.

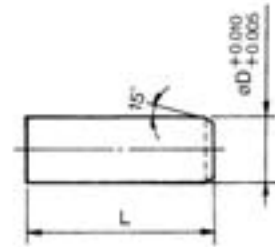

(mm)

| Model | L | øD | Model* |
|---------------|----|----|--------|
| CXWL10 | 10 | 4 | MS4-10 |
| CXWL16 | 10 | 5 | MS5-10 |
| CXWL20 | 15 | 6 | MS6-15 |
| CXWL25 | 15 | 6 | MS6-15 |
| CXWL32 | 20 | 8 | MS8-20 |

* Manufactured by Misumi Trading Ltd.

Deflection of Piston Rod by Center Loading (Reference)

When center loading is added to the center of the housing

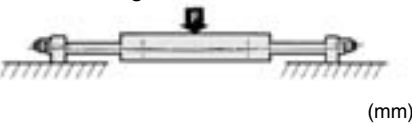

| Model | Stroke (mm) | | |
|---------------|-------------|------|------|
| | Load (N) | 100 | 200 |
| CXWL10 | 9.81 | 0.07 | – |
| CXWL16 | 39.2 | 0.05 | 0.20 |
| CXWL20 | 49 | 0.04 | 0.15 |
| CXWL25 | 68.6 | 0.03 | 0.10 |
| CXWL32 | 98.1 | 0.02 | 0.07 |

When center loading is added to the center of the plate

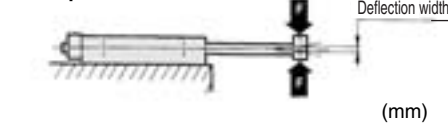

| Model | Stroke (mm) | | | | |
|---------------|-------------|------|------|------|------|
| | Load (N) | 50 | 100 | 150 | 200 |
| CXWL10 | 2.94 | 0.06 | 0.30 | – | – |
| CXWL16 | 4.90 | 0.03 | 0.10 | 0.25 | 0.45 |
| CXWL20 | 7.84 | 0.03 | 0.09 | 0.18 | 0.35 |
| CXWL25 | 9.81 | 0.03 | 0.09 | 0.16 | 0.25 |
| CXWL32 | 29.42 | 0.02 | 0.05 | 0.10 | 0.15 |

Note) The values denote the total width of the deflections in the upward/downward direction.

CX2

CXW

CXT

CXSJ

CXS

D-□

-X□

Individual
-X□

Series CXWL

Construction: $\varnothing 10$, $\varnothing 16$, $\varnothing 25$

CXWL10

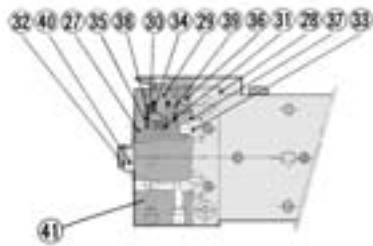

With end lock

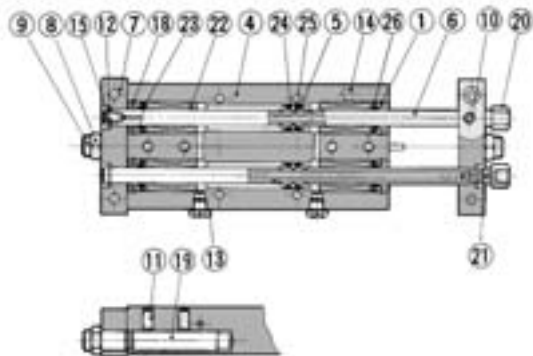

CXWL16

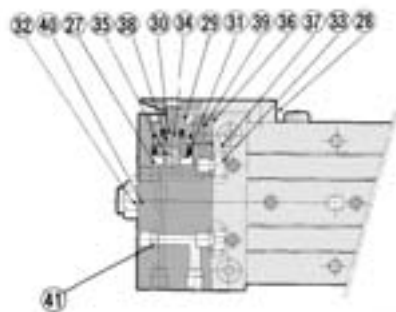

With end lock

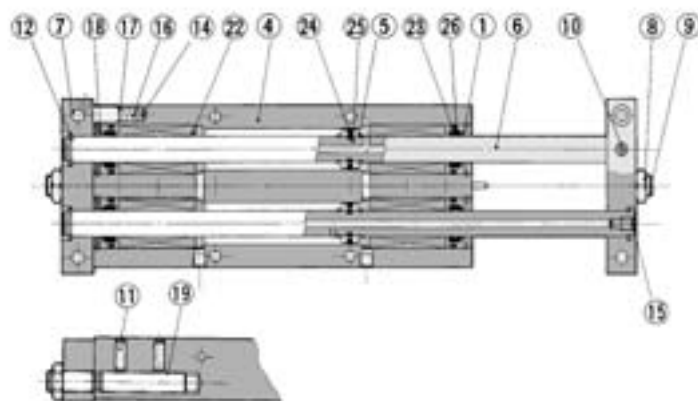

CXWL25

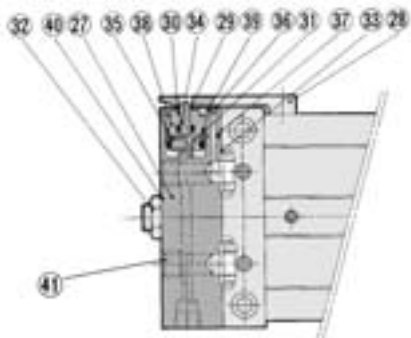

With end lock

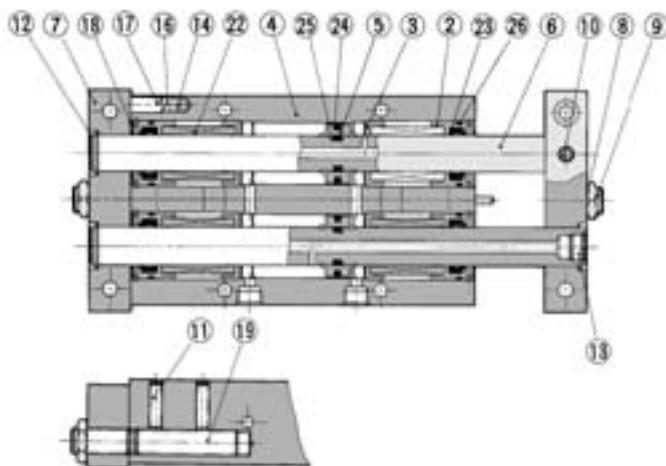

Construction: ø10, ø16, ø25

Component Parts

| No. | Description | Material | Note |
|-----|--|--|------------------------------|
| 1 | Rod cover | Aluminum alloy | Anodized |
| 2 | Rod cover A | Aluminum alloy | Anodized |
| 3 | Rod cover B | Aluminum alloy | Anodized |
| 4 | Housing | Aluminum alloy | Hard anodized |
| 5 | Piston | Aluminum alloy | Chromated |
| 6 | Piston rod | High carbonate chrome bearing steel pipe | Quenched, Hard chrome plated |
| 7 | Plate | Aluminum alloy | Hard anodized |
| 8 | Lock nut | Carbon steel | Nickel plated |
| 9 | Adjusting bolt | Chromium steel | Nickel plated |
| 10 | Set screw (For fixing rods) | Chromium steel | Nickel plated |
| 11 | Set screw (For fixing shock absorbers) | Stainless steel | |
| 12 | Retaining ring | Carbon tool steel | Nickel plated |
| 13 | Plug | Brass | Nickel plated |
| 14 | Magnet | — | ø5 |
| 15 | Set screw for seal | Chromium steel | Nickel plated |
| 16 | Spring | Stainless steel | |
| 17 | Type CR retaining ring | Carbon tool steel | |
| 18 | Round type R retaining ring | Carbon tool steel | Nickel plated |
| 19 | Shock absorber | — | (RB0805-X552 or RB1006-X552) |
| 20 | Socket | Brass | Electroless nickel plated |
| 21 | Gasket | NBR | |
| 22 | Ball bushing | — | |
| 23 | Rod seal | NBR | |
| 24 | Piston seal | NBR | |
| 25 | Piston gasket | NBR | |
| 26 | Cylinder tube gasket | NBR | |

Component Parts: With End Lock

| No. | Description | Material | Note |
|-----|-----------------------------|----------------------------------|--|
| 27 | Locking body | Aluminum alloy | Hard anodized |
| 28 | Lock finger | Alloy tool steel | Nickel plated after quenched |
| 29 | Lock piston | Carbon tool steel | Electroless nickel plated after quenched |
| 30 | Rod cover | Aluminum alloy | |
| 31 | Return spring | Spring steel | Zinc chromated |
| 32 | Adjusting bolt | Chromium steel | Nickel plated |
| 33 | Body gasket | NBR | |
| 34 | Rod seal | NBR | |
| 35 | Piston seal | NBR | |
| 36 | Steel ball | High carbon chrome bearing steel | |
| 37 | Steel ball | High carbon chrome bearing steel | |
| 38 | O-ring | NBR | |
| 39 | Round type R retaining ring | Carbon tool steel | Nickel plated |
| 40 | Lock nut | Carbon steel | Nickel plated |
| 41 | Plug | Chromium steel | Nickel plated |

**Replacement Parts: Seal Kit
End Lock**

| Model | Kit no. | Contents |
|--------|------------|---|
| CXWL10 | CXWL10R-PS | A set of ③③, ③④, ③⑤ and ③⑧ listed above |
| CXWL16 | CXWL16R-PS | |
| CXWL25 | CXWL25R-PS | |

* Seal kit includes ③③, ③④, ③⑤ and ③⑧. Order the seal kit with the part number for each model.
* Since the seal kit does not include a grease pack, order it separately.
Grease pack part no.: GR-S-010 (10 g)

**Replacement Parts: Seal Kit
Cylinder Body**

| Model | Kit no. | Contents |
|--------|-----------|-------------------------------------|
| CXWL10 | CXWL10-PS | A set of ②③, ②④ and ②⑥ listed above |
| CXWL16 | CXWL16-PS | |
| CXWL25 | CXWL25-PS | |

* Seal kit includes ②③, ②④ and ②⑥. Order the seal kit with the part number for each model.
* ②⑤ is not replaceable.
* Since the seal kit does not include a grease pack, order it separately.
Grease pack part no.: GR-S-010 (10 g)

CX2

CXW

CXT

CXSJ

CXS

D-□

-X□

**Individual
-X□**

Series CXWL

Construction: $\varnothing 20$, $\varnothing 32$

CXWL20

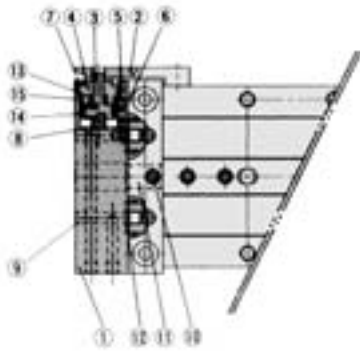

With end lock

CXWL32

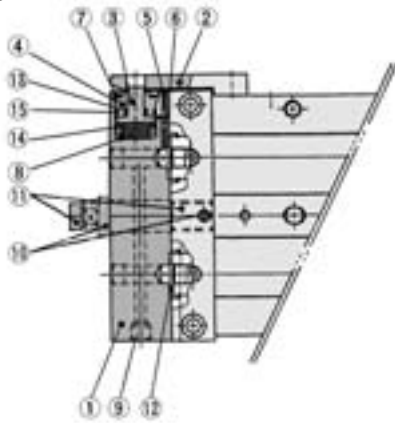

With end lock

Component Parts

| No. | Description | Material | Note |
|-----|-----------------------------|----------------------------------|----------------------------|
| 1 | Rod cover | Aluminum alloy | Anodized |
| 2 | Rod cover A | Aluminum alloy | Anodized |
| 3 | Rod cover B | Aluminum alloy | Anodized |
| 4 | Housing | Aluminum alloy | Hard anodized |
| 5 | Piston | Aluminum alloy | Chromated |
| 6 | Piston rod | High carbon chrome bearing steel | — |
| 7 | Plate | Aluminum alloy | Hard anodized |
| 8 | Adjusting bolt | Chromium steel | Nickel plated |
| 9 | Hex. socket head set screw | Chromium steel | Nickel plated |
| 10 | Hex. socket head set screw | Chromium steel | Nickel plated |
| 11 | Retaining ring | Tool steel | Nickel plated |
| 12 | Magnet | — | $\varnothing 5$ |
| 13 | Spring | Stainless steel | |
| 14 | Type CR retaining ring | Carbon tool steel | |
| 15 | Round type R retaining ring | Carbon tool steel | Nickel plated |
| 16 | Ball bushing | — | |
| 17 | Shock absorber | — | RB1006-X552 or RB1411-X552 |
| 18 | Plug | Chromium steel | Nickel plated |
| 19 | Hex. socket head set screw | Stainless steel | |
| 21 | Piston seal | NBR | |
| 22 | Rod seal | NBR | |
| 23 | Piston gasket | NBR | |
| 24 | Cylinder tube gasket | NBR | |

Replacement Parts: Seal Kit Cylinder Body

| Model | Kit no. | Contents |
|--------|-----------|----------------------------------|
| CXWL20 | CXWL20-PS | A set of ①, ② and ④ listed above |
| CXWL32 | CXWL32-PS | |

- * Seal kit includes ①, ② and ④. Order the seal kit with the part number for each model.
 - * ③ is not replaceable.
 - * Since the seal kit does not include a grease pack, order it separately.
- Grease pack part no.: GR-S-010 (10 g)**

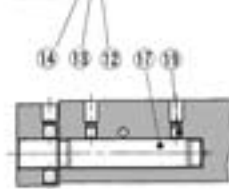
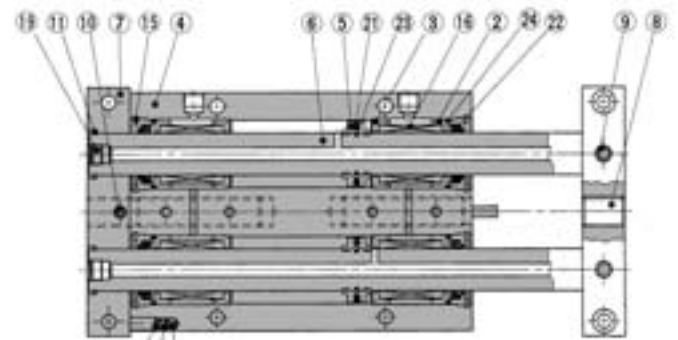
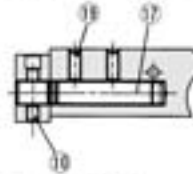
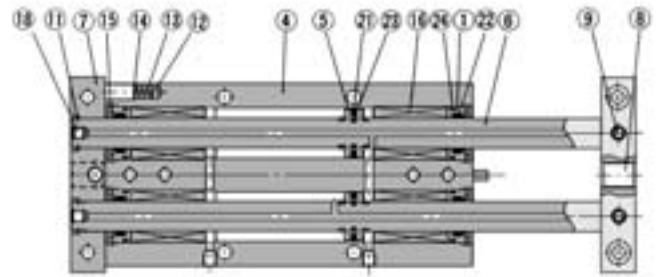

Component Parts: With End Lock

| No. | Description | Material | Note |
|---------|-----------------------------|----------------------------------|--|
| 1 | Locking body | Aluminum alloy | Hard anodized |
| 2 | Lock finger | Alloy tool steel | Nickel plating after quenched |
| 3 | Lock piston | Tool steel | Electroless nickel plated after quenched |
| 4 | Rod cover | Aluminum bearing alloy | |
| 5 | Steel ball | High carbon chrome bearing steel | |
| 6 | Steel ball | High carbon chrome bearing steel | |
| 7 | Round type R retaining ring | Carbon tool steel | Nickel plated |
| 8 | Return spring | Spring steel | Zinc chromated |
| 9 | Plug | Chromium steel | Nickel plated |
| Note 10 | 25, (50) to 200 ST (25) ST | Hexagon socket head set screw | Chromium steel |
| | | Hexagon nut | Carbon steel |
| Note 11 | 25, (50) to 200 ST (25) ST | Adjusting bolt | Chromium steel |
| | | Shock absorber | — |
| 12 | Body gasket | NBR | |
| 13 | Rod seal | NBR | |
| 14 | Piston seal | NBR | |
| 15 | O-ring | NBR | |

Note) Figures in parentheses denote the case of CXWM32.

Replacement Parts: Seal Kit End Lock

| Model | Kit no. | Contents |
|--------|------------|-------------------------------------|
| CXWL20 | CXWL20R-PS | A set of ⑫, ⑬, ⑭ and ⑮ listed above |
| CXWL32 | CXWL32R-PS | |

- * Seal kit includes ⑫, ⑬, ⑭ and ⑮. Order the seal kit with the part number for each model.
 - * Since the seal kit does not include a grease pack, order it separately.
- Grease pack part no.: GR-S-010 (10 g)**

Slide Unit: Built-in Shock Absorber Ball Bushing Bearing Type **Series CXWL**

ø10 Basic Type: CXWL10-Stroke/25 to 100

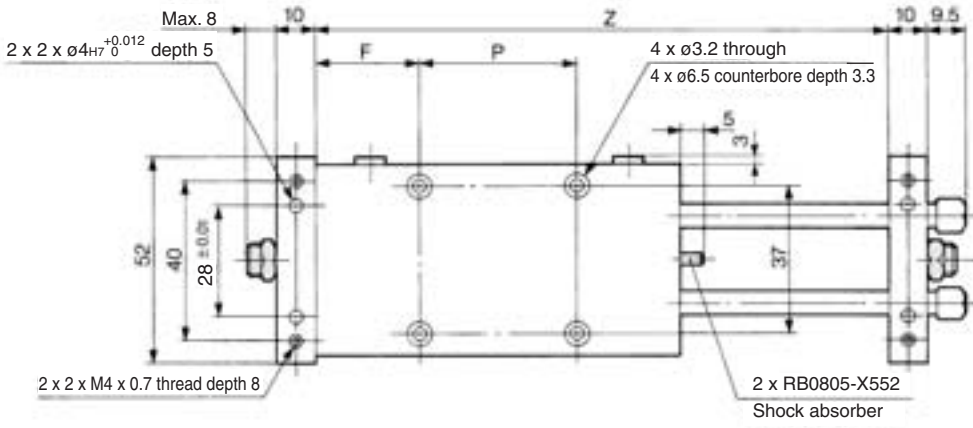
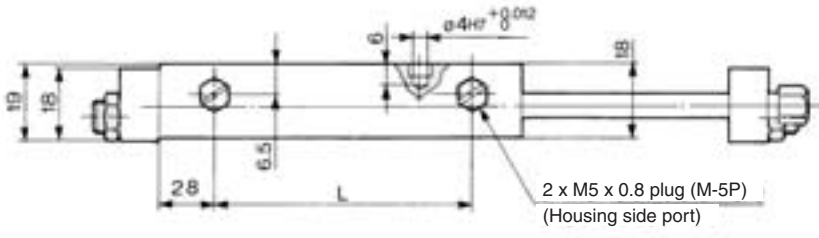
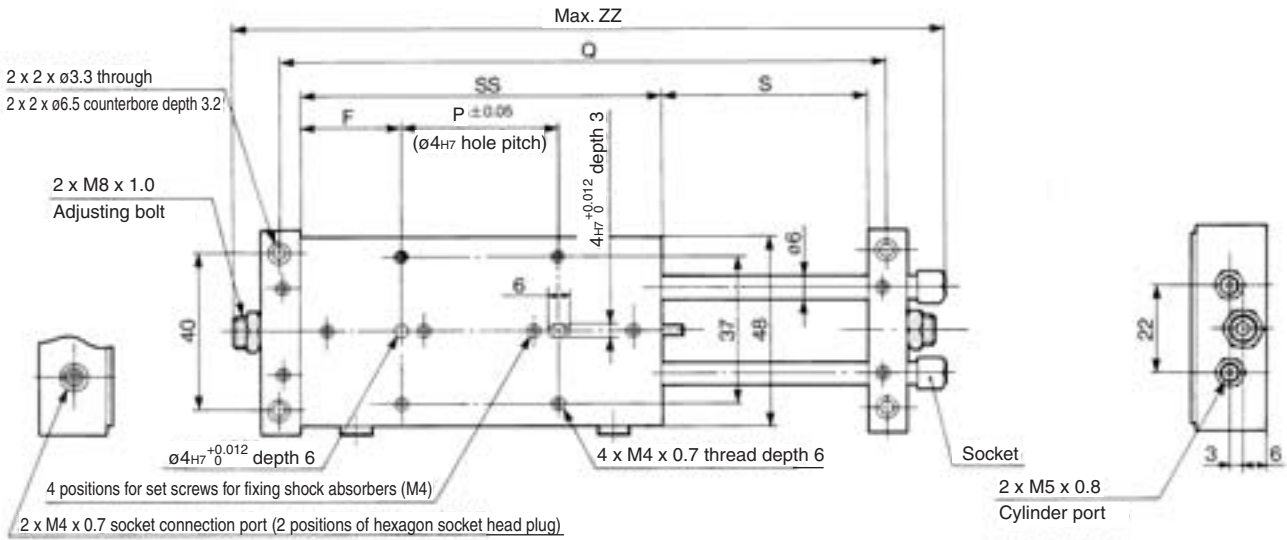

| Model | F | L | P | Q | S | SS | Z | ZZ |
|------------|------|-----|----|-----|-----|-----|-----|-------|
| CXWL10-25 | 35.5 | 45 | 30 | 138 | 27 | 101 | 128 | 165.5 |
| CXWL10-50 | 38 | 70 | 50 | 188 | 52 | 126 | 178 | 215.5 |
| CXWL10-75 | 40.5 | 95 | 70 | 238 | 77 | 151 | 228 | 265.5 |
| CXWL10-100 | 43 | 120 | 90 | 288 | 102 | 176 | 278 | 315.5 |

(mm)

- CX2**
- CXW**
- CXT**
- CXSJ**
- CXS**
- D-□**
- X□**
- Individual**
- X□**

Slide Unit: Built-in Shock Absorber Ball Bushing Bearing Type *Series CXWL*

ø16 Basic Type: CXWL16-Stroke/25 to 200

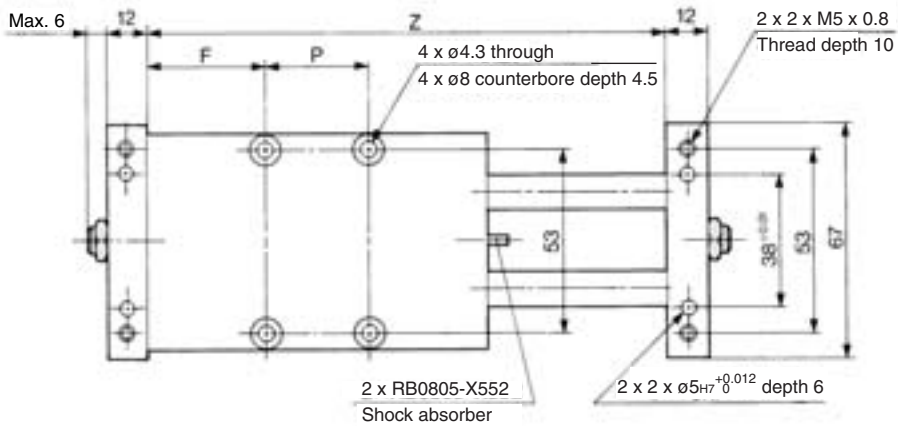
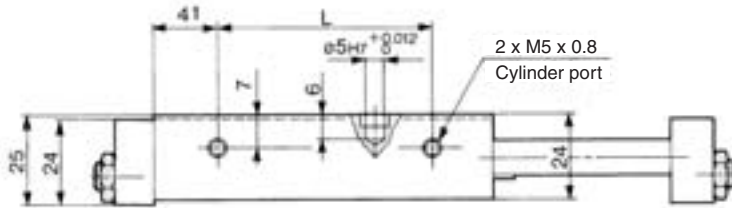
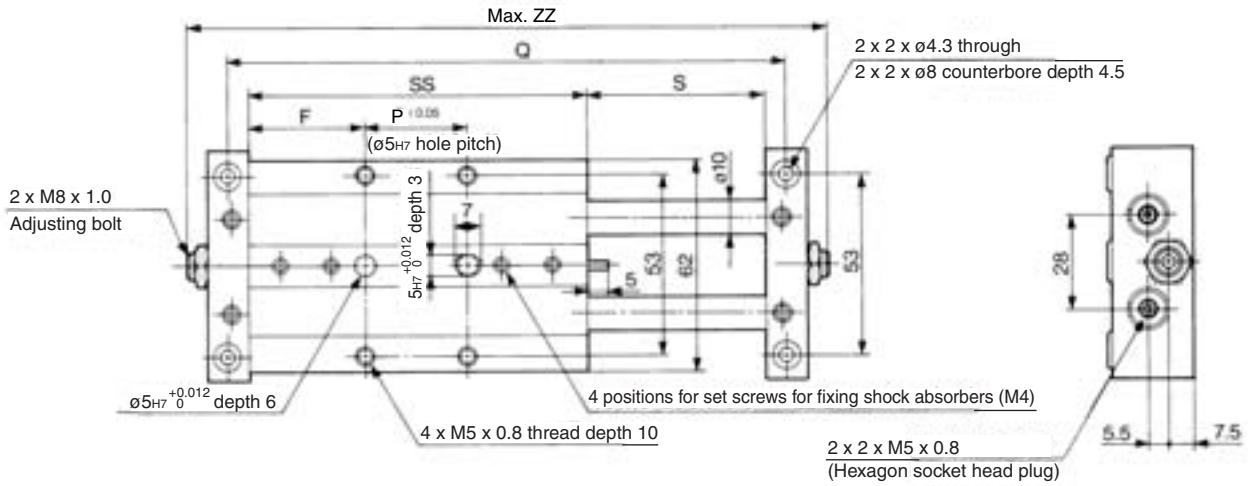

| Model | F | L | P | Q | S | SS | Z | ZZ |
|------------|------|-----|----|-----|-----|-----|-----|-----|
| CXWL16-25 | 34.5 | 39 | 52 | 160 | 27 | 121 | 148 | 184 |
| CXWL16-50 | 47 | 64 | 52 | 210 | 52 | 146 | 198 | 234 |
| CXWL16-75 | 53 | 89 | 65 | 260 | 77 | 171 | 248 | 284 |
| CXWL16-100 | 53 | 114 | 90 | 310 | 102 | 196 | 298 | 334 |
| CXWL16-125 | 65.5 | 139 | 90 | 360 | 127 | 221 | 348 | 384 |
| CXWL16-150 | 78 | 164 | 90 | 410 | 152 | 246 | 398 | 434 |
| CXWL16-175 | 90.5 | 189 | 90 | 460 | 177 | 271 | 448 | 484 |
| CXWL16-200 | 103 | 214 | 90 | 510 | 202 | 296 | 498 | 534 |

CX2

CXW

CXT

CXSJ

CXS

D-□

-X□

**Individual
-X□**

Slide Unit: Built-in Shock Absorber Ball Bushing Bearing Type **Series CXWL**

ø20 Basic Type: CXWL20-Stroke/25 to 200

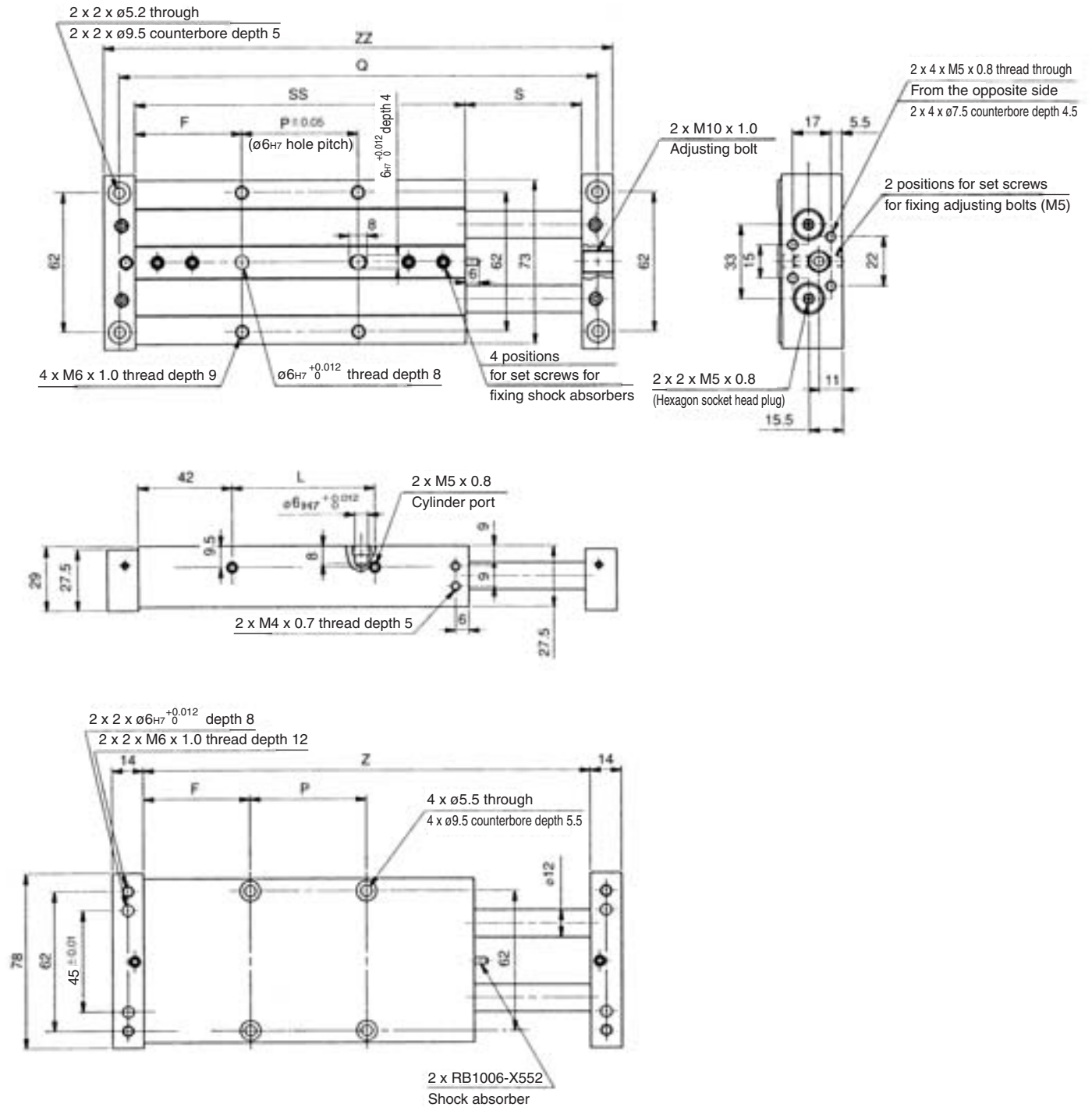

| Model | F | L | P | Q | S | SS | Z | ZZ |
|------------|------|-----|----|-----|-----|-----|-----|-----|
| CXWL20-25 | 35.5 | 39 | 52 | 164 | 27 | 123 | 150 | 178 |
| CXWL20-50 | 48 | 64 | 52 | 214 | 52 | 148 | 200 | 228 |
| CXWL20-75 | 56.5 | 89 | 60 | 264 | 77 | 173 | 250 | 278 |
| CXWL20-100 | 54 | 114 | 90 | 314 | 102 | 198 | 300 | 328 |
| CXWL20-125 | 66.5 | 139 | 90 | 364 | 127 | 223 | 350 | 378 |
| CXWL20-150 | 79 | 164 | 90 | 414 | 152 | 248 | 400 | 428 |
| CXWL20-175 | 91.5 | 189 | 90 | 464 | 177 | 273 | 450 | 478 |
| CXWL20-200 | 104 | 214 | 90 | 514 | 202 | 298 | 500 | 528 |

(mm)

CX2

CXW

CXT

CXSJ

CXS

D-□

-X□

**Individual
-X□**

Series CXWL

ø20 With End Lock: CXWL20-Stroke/25 to 200R

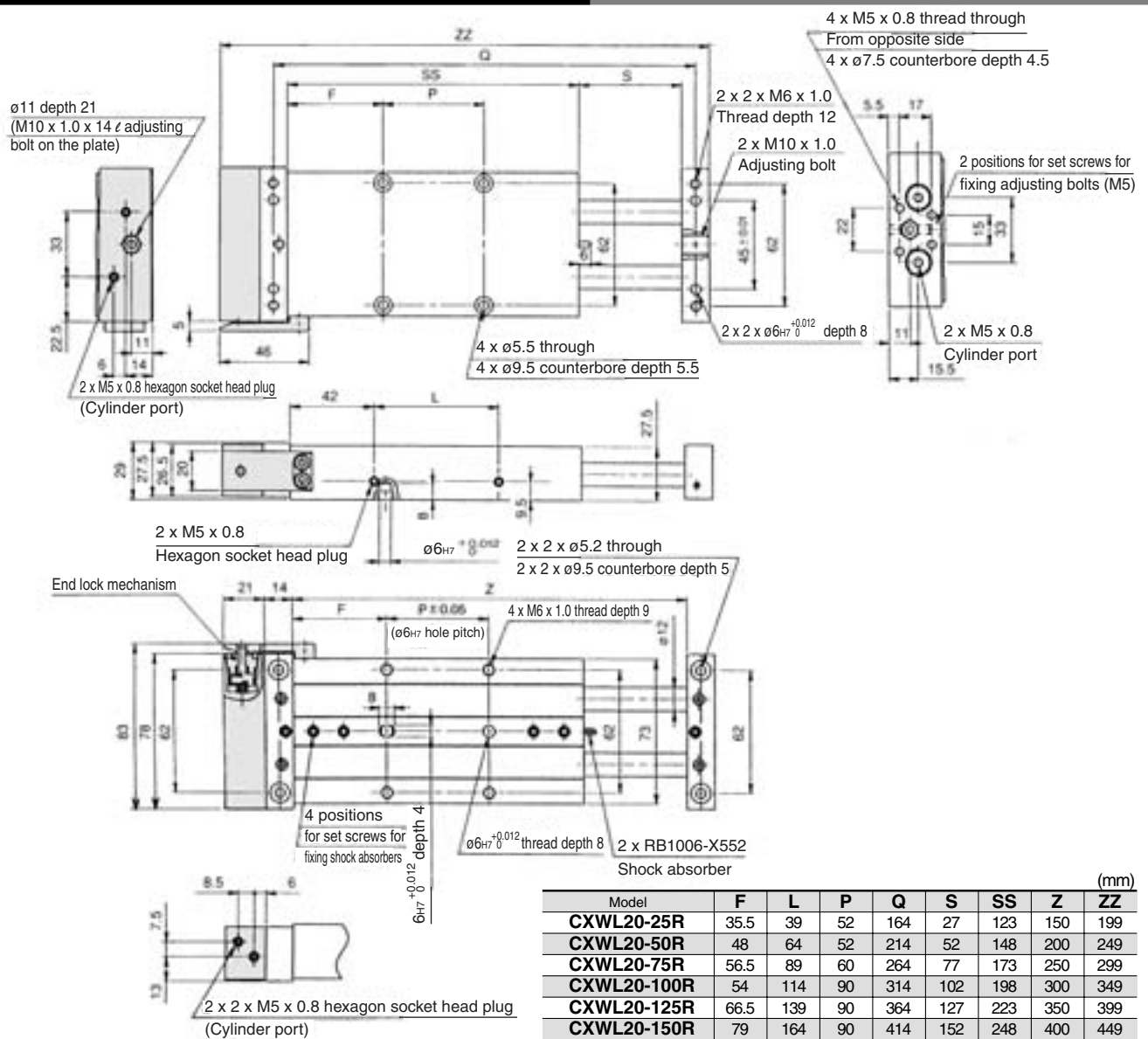

| Model | F | L | P | Q | S | SS | Z | ZZ |
|-------------|------|-----|----|-----|-----|-----|-----|-----|
| CXWL20-25R | 35.5 | 39 | 52 | 164 | 27 | 123 | 150 | 199 |
| CXWL20-50R | 48 | 64 | 52 | 214 | 52 | 148 | 200 | 249 |
| CXWL20-75R | 56.5 | 89 | 60 | 264 | 77 | 173 | 250 | 299 |
| CXWL20-100R | 54 | 114 | 90 | 314 | 102 | 198 | 300 | 349 |
| CXWL20-125R | 66.5 | 139 | 90 | 364 | 127 | 223 | 350 | 399 |
| CXWL20-150R | 79 | 164 | 90 | 414 | 152 | 248 | 400 | 449 |
| CXWL20-175R | 91.5 | 189 | 90 | 464 | 177 | 273 | 450 | 499 |
| CXWL20-200R | 104 | 214 | 90 | 514 | 202 | 298 | 500 | 549 |

Housing mounting style with auto switch CDBXWL20-Stroke, CDBXWL20-Stroke R

Plate mounting style with auto switch CDPXWL20-Stroke, CDPXWL20-Stroke R

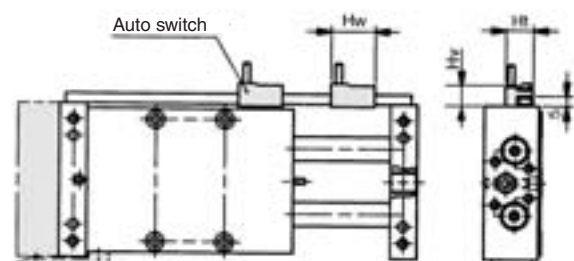
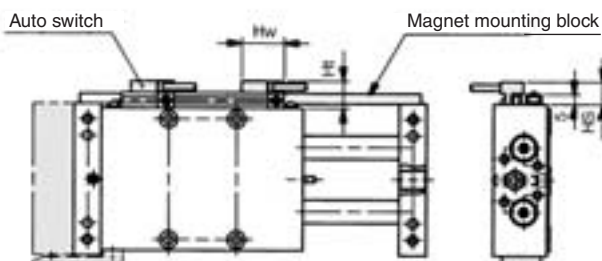

Note 1) The dimensions show D-A7 and D-A8. (mm)

| Auto switch model | Hw | Hs | Ht |
|--|----|------|------|
| D-A7□, D-A80 | 23 | 12.5 | 15 |
| D-F7□, D-J79, D-J79W, D-F7□W, D-F79F, D-F7BAL, D-F7NTL | 23 | 12.5 | 15 |
| D-A7□H, D-A80H | 22 | 12.5 | 15 |
| D-A73C, D-A80C | 23 | 15 | 17.5 |
| D-F7□V, D-F7□WV, D-F7BAV | 23 | 12.5 | 15 |
| D-J79C | 24 | 15 | 17.5 |
| D-7LF | 30 | 12.5 | 15 |

Note 1) The dimensions show D-A7 and D-A8. (mm)

| Auto switch model | Hw | Ht | Hv |
|--|----|------|------|
| D-A7□, D-A80 | 23 | 15 | 10.5 |
| D-F7□, D-J79, D-J79W, D-F7□W, D-F79F, D-F7BAL, D-F7NTL | 23 | 15 | 10 |
| D-A7□H, D-A80H | 22 | 15 | 9 |
| D-A73C, D-A80C | 23 | 17.5 | 17.5 |
| D-F7□V, D-F7□WV, D-F7BAV | 23 | 15 | 14 |
| D-J79C | 24 | 17.5 | 16 |

Note 2) For 25 stroke, 2 magnets for auto switches are equipped to the magnet mounting block.

Slide Unit: Built-in Shock Absorber Ball Bushing Bearing Type **Series CXWL**

ø25 Basic Type: CXWL25-Stroke/25 to 200

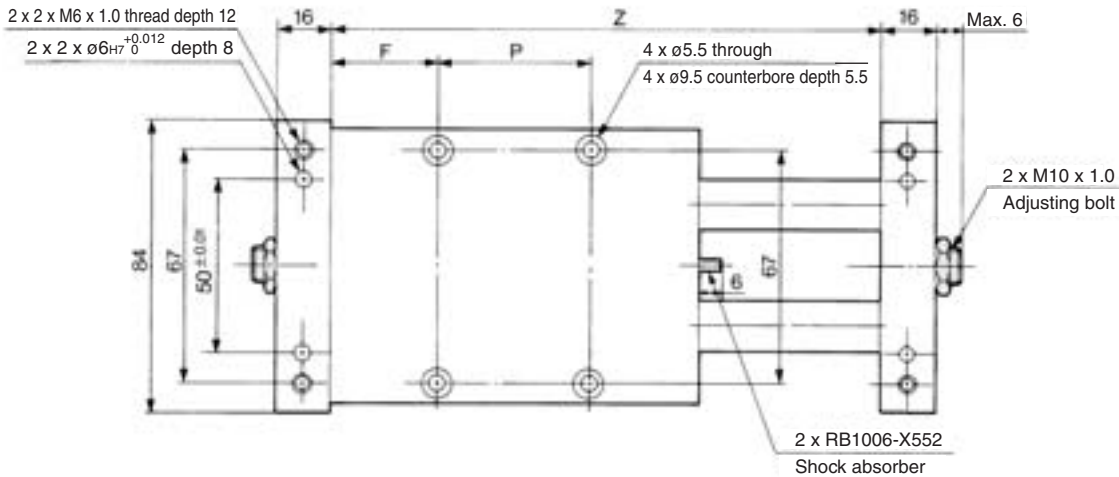
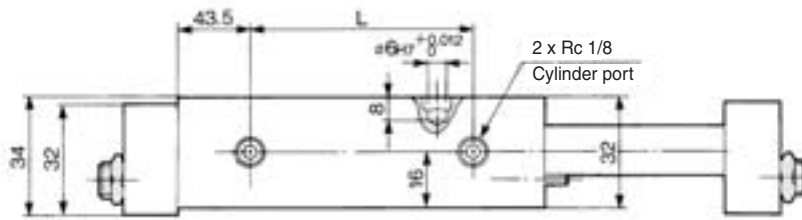
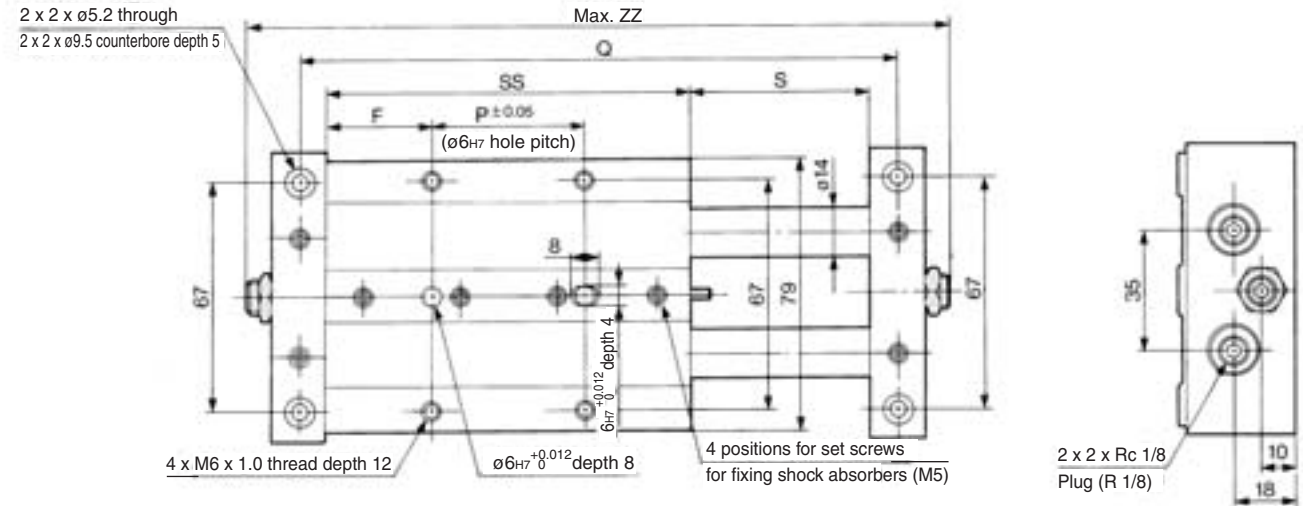

| Model | F | L | P | Q | S | SS | Z | ZZ |
|-------------------|-------|-----|----|-----|-----|-----|-----|-----|
| CXWL25-25 | 31.5 | 41 | 65 | 171 | 27 | 128 | 155 | 199 |
| CXWL25-50 | 31.5 | 66 | 90 | 221 | 52 | 153 | 205 | 249 |
| CXWL25-75 | 56.5 | 91 | 65 | 271 | 77 | 178 | 255 | 299 |
| CXWL25-100 | 56.5 | 116 | 90 | 321 | 102 | 203 | 305 | 349 |
| CXWL25-125 | 69 | 141 | 90 | 371 | 127 | 228 | 355 | 399 |
| CXWL25-150 | 81.5 | 166 | 90 | 421 | 152 | 253 | 405 | 449 |
| CXWL25-175 | 94 | 191 | 90 | 471 | 177 | 278 | 455 | 499 |
| CXWL25-200 | 106.5 | 216 | 90 | 521 | 202 | 303 | 505 | 549 |

CX2

CXW

CXT

CXSJ

CXS

D-□

-X□

Individual
-X□

Series CXWL

ø25 With End Lock: CXWL25-Stroke/25 to 200R

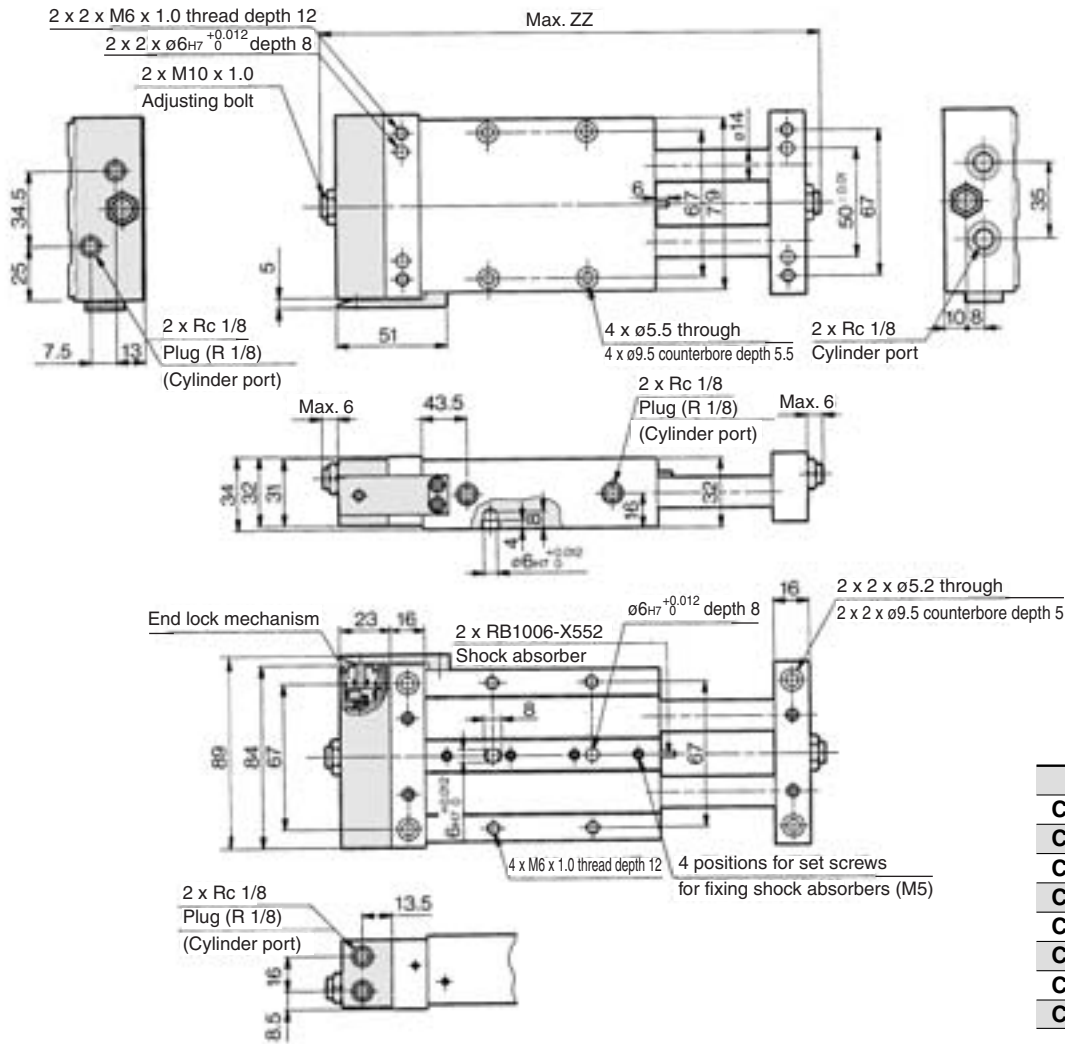

| Model | ZZ (mm) |
|-------------|---------|
| CXWL25-25R | 222 |
| CXWL25-50R | 272 |
| CXWL25-75R | 322 |
| CXWL25-100R | 372 |
| CXWL25-125R | 422 |
| CXWL25-150R | 472 |
| CXWL25-175R | 522 |
| CXWL25-200R | 572 |

Housing mounting style with auto switch CDBXWL25-Stroke, CDBXWL25-Stroke R

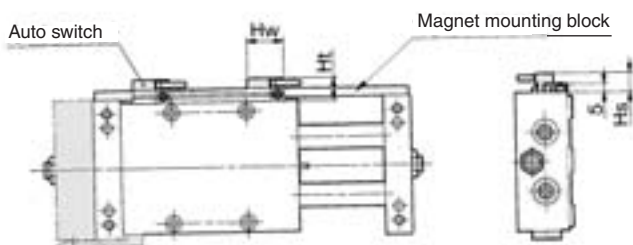

Note 1) The dimensions show D-A7 and D-A8. (mm)

| Auto switch model | Hw | Hs | Ht |
|--|----|------|------|
| D-A7□, D-A80 | 23 | 12.5 | 15 |
| D-F7□, D-J79, D-J79W, D-F7□W, D-F79F, D-F7BAL, D-F7NTL | 23 | 12.5 | 15 |
| D-A7□H, D-A80H | 22 | 12.5 | 15 |
| D-A73C, D-A80C | 23 | 15 | 17.5 |
| D-F7□V, D-F7□WV, D-F7BAV | 23 | 12.5 | 15 |
| D-J79C | 24 | 15 | 17.5 |
| D-F7LF | 30 | 12.5 | 15 |

Note 2) For only 25 stroke, 2 magnets for auto switches are equipped to the magnet mounting block.

Plate mounting style with auto switch CDPXWL25-Stroke, CDPXWL25-Stroke R

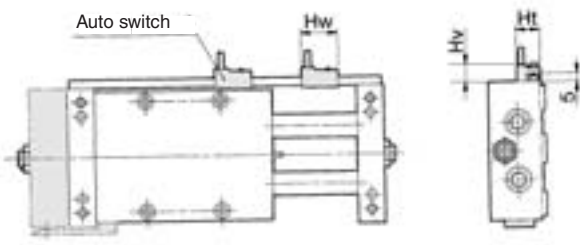

Note 1) The dimensions show D-A7 and D-A8. (mm)

| Auto switch model | Hw | Ht | Hv |
|--|----|------|------|
| D-A7□, D-A80 | 23 | 15 | 10.5 |
| D-F7□, D-J79, D-J79W, D-F7□W, D-F79F, D-F7BAL, D-F7NTL | 23 | 15 | 10 |
| D-A7□H, D-A80H | 22 | 15 | 9 |
| D-A73C, D-A80C | 23 | 17.5 | 17.5 |
| D-F7□V, D-F7□WV, D-F7BAV | 23 | 15 | 14 |
| D-J79C | 24 | 17.5 | 16 |

Note 2) For only 25 stroke, 2 magnets for auto switches are built into the housing.

Slide Unit: Built-in Shock Absorber Ball Bushing Bearing Type **Series CXWL**

ø32 Basic Type: CXWL32-Stroke/50 to 200

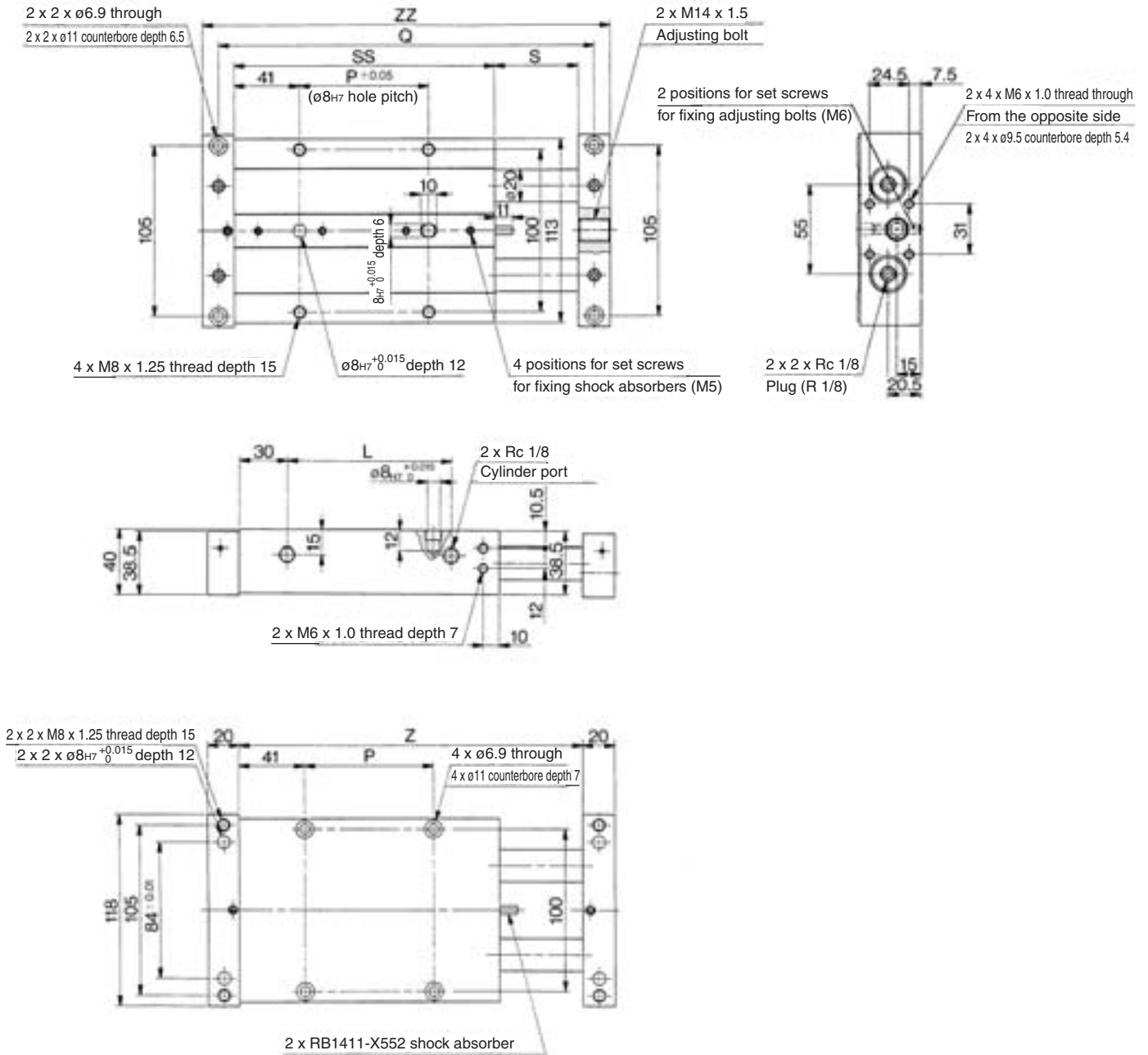

(mm)

| Model | L | P | Q | S | SS | Z | ZZ |
|-------------------|-----|-----|-----|-----|-----|-----|-----|
| CXWL32-50 | 102 | 80 | 234 | 52 | 162 | 214 | 254 |
| CXWL32-75 | 127 | 105 | 284 | 77 | 187 | 264 | 304 |
| CXWL32-100 | 152 | 130 | 334 | 102 | 212 | 314 | 354 |
| CXWL32-125 | 177 | 155 | 384 | 127 | 237 | 364 | 404 |
| CXWL32-150 | 202 | 180 | 434 | 152 | 262 | 414 | 454 |
| CXWL32-175 | 227 | 205 | 484 | 177 | 287 | 464 | 504 |
| CXWL32-200 | 252 | 230 | 534 | 202 | 312 | 514 | 554 |

CX2

CXW

CXT

CXSJ

CXS

D-□

-X□

**Individual
-X□**

Series CXWL

ø32 Basic Type: CXWL32-25 stroke

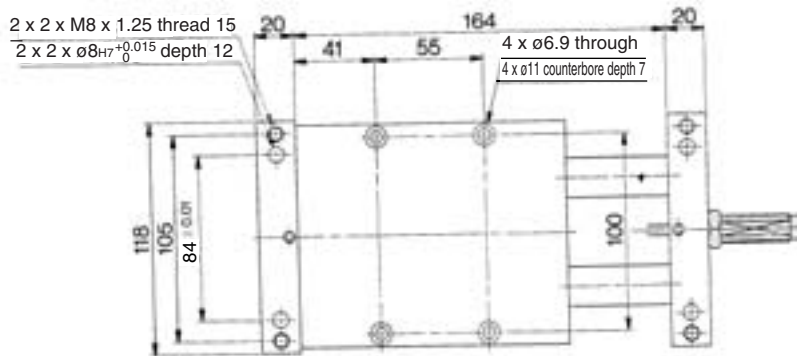
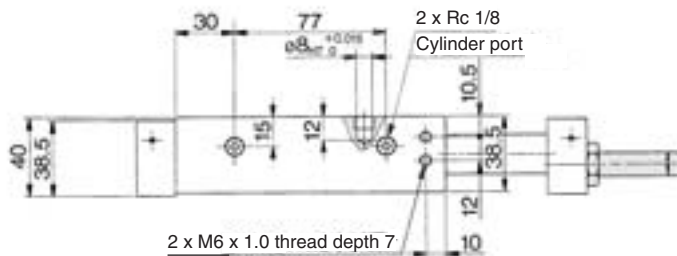
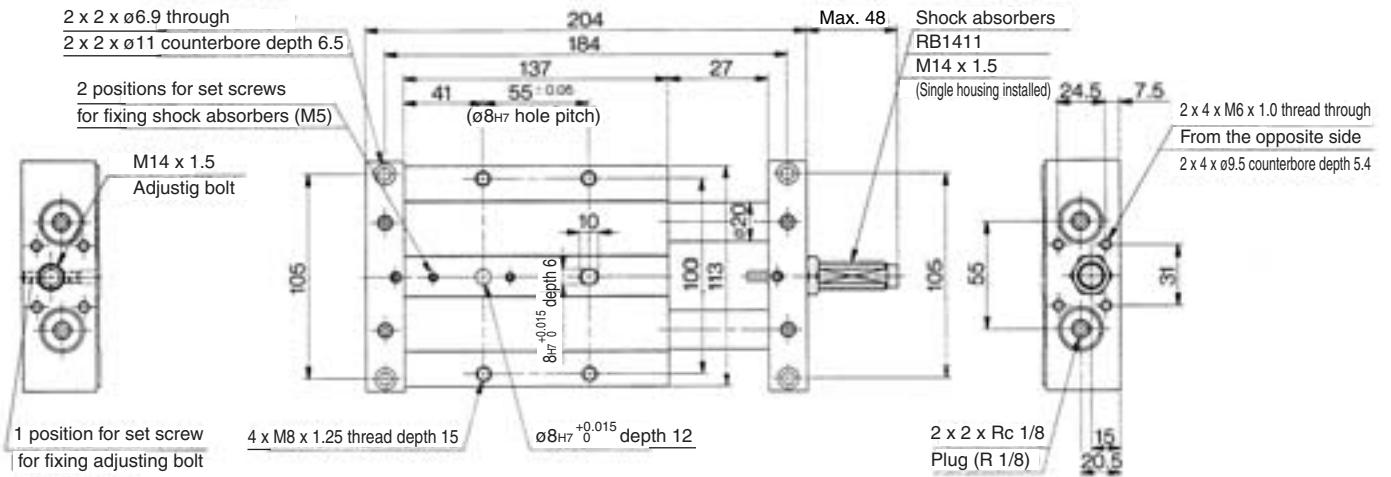

ø32 With End Lock: CXWL32-Stroke/50 to 200 R

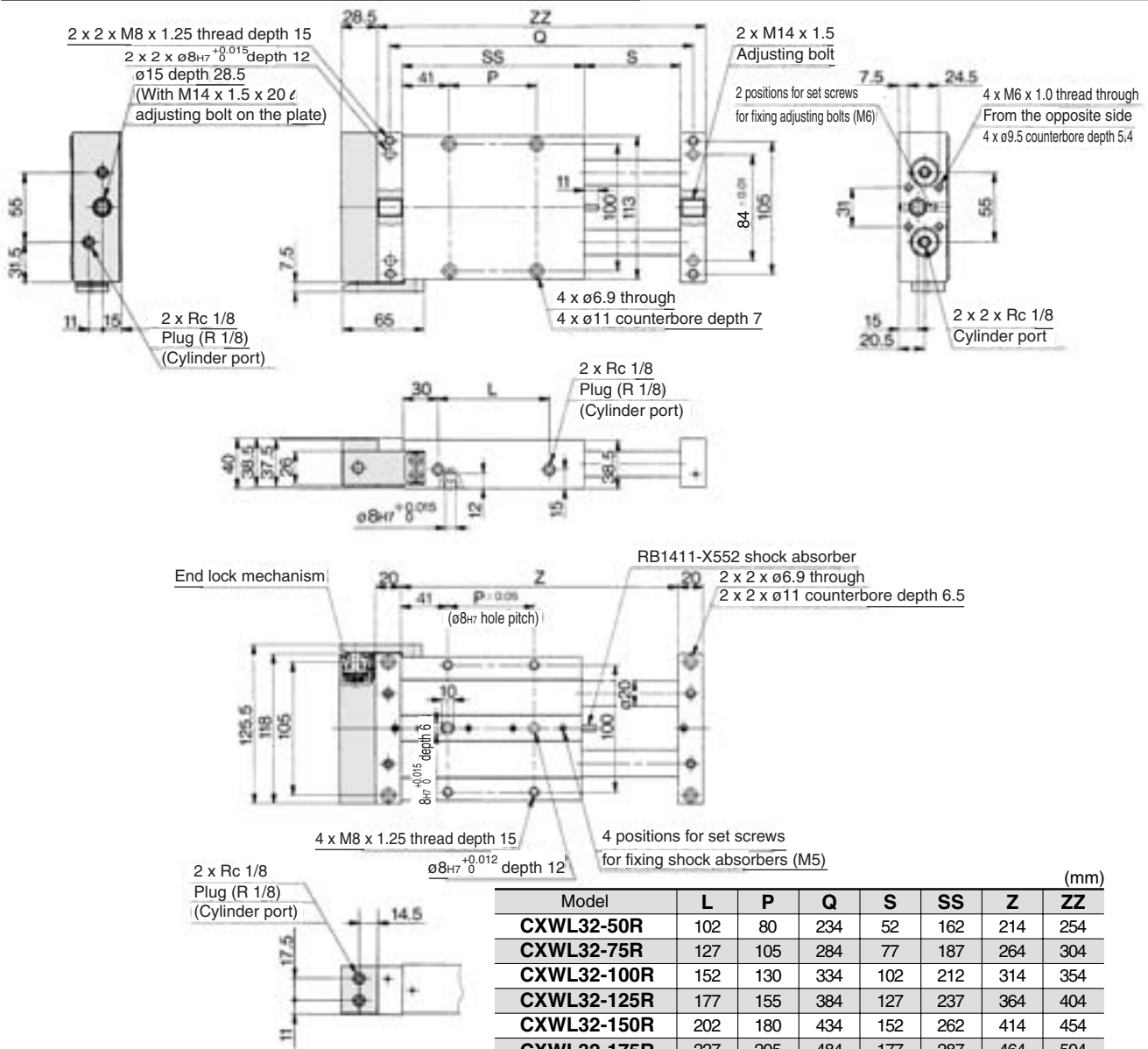

| Model | L | P | Q | S | SS | Z | ZZ |
|-------------|-----|-----|-----|-----|-----|-----|-----|
| CXWL32-50R | 102 | 80 | 234 | 52 | 162 | 214 | 254 |
| CXWL32-75R | 127 | 105 | 284 | 77 | 187 | 264 | 304 |
| CXWL32-100R | 152 | 130 | 334 | 102 | 212 | 314 | 354 |
| CXWL32-125R | 177 | 155 | 384 | 127 | 237 | 364 | 404 |
| CXWL32-150R | 202 | 180 | 434 | 152 | 262 | 414 | 454 |
| CXWL32-175R | 227 | 205 | 484 | 177 | 287 | 464 | 504 |
| CXWL32-200R | 252 | 230 | 534 | 202 | 312 | 514 | 554 |

Housing mounting style with auto switch
CDBXWL32-Stroke, CDBXWL32-Stroke R

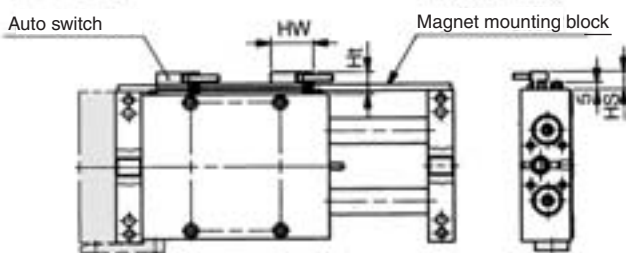

Note 1) The dimensions show D-A7 and D-A8. (mm)

| Auto switch model | Hw | Hs | Ht |
|---|----|------|------|
| D-A7□, D-A80 | 23 | 12.5 | 15 |
| D-F7□, D-J79, D-J79W, D-F7□W, D-F79F, D-F7BAL, D-F7NTL | 23 | 12.5 | 15 |
| D-A7□H, D-A80H | 22 | 12.5 | 15 |
| D-A73C, D-A80C | 23 | 15 | 17.5 |
| D-F7□V, D-F7□WV, D-F7BAV | 23 | 12.5 | 15 |
| D-J79C | 24 | 15 | 17.5 |
| D-F7LF | 30 | 12.5 | 15 |

Note 2) For 25 stroke, the shock absorber is mounted on a single side of the plate. For dimensions of 25 stroke, refer to page 516.

Plate mounting style with auto switch
CDPXWL32-Stroke, CDPXWL32-Stroke R

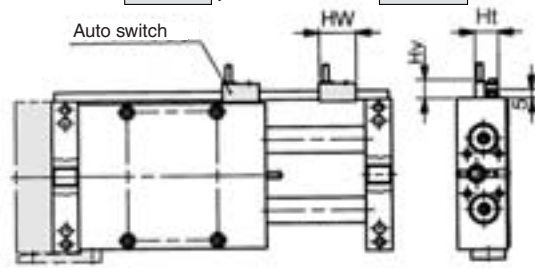

Note 1) The dimensions show D-A7 and D-A8. (mm)

| Auto switch model | Hw | Ht | Hv |
|---|----|------|------|
| D-A7□, D-A80 | 23 | 15 | 10.5 |
| D-F7□, D-J79, D-J79W, D-F7□W, D-F79F, D-F7BAL, D-F7NTL | 23 | 15 | 10 |
| D-A7□H, D-A80H | 22 | 15 | 9 |
| D-A73C, D-A80C | 23 | 17.5 | 17.5 |
| D-F7□V, D-F7□WV, D-F7BAV | 23 | 15 | 14 |
| D-J79C | 24 | 17.5 | 16 |

Note 2) For 25 stroke, the shock absorber is mounted on a single side of the plate. For dimensions of 25 stroke, refer to page 516.

CX2

CXW

CXT

CXSJ

CXS

D-□

-X□

Individual

-X□

Series CXWL

ø32 With End Lock: CXWL32-25 stroke R

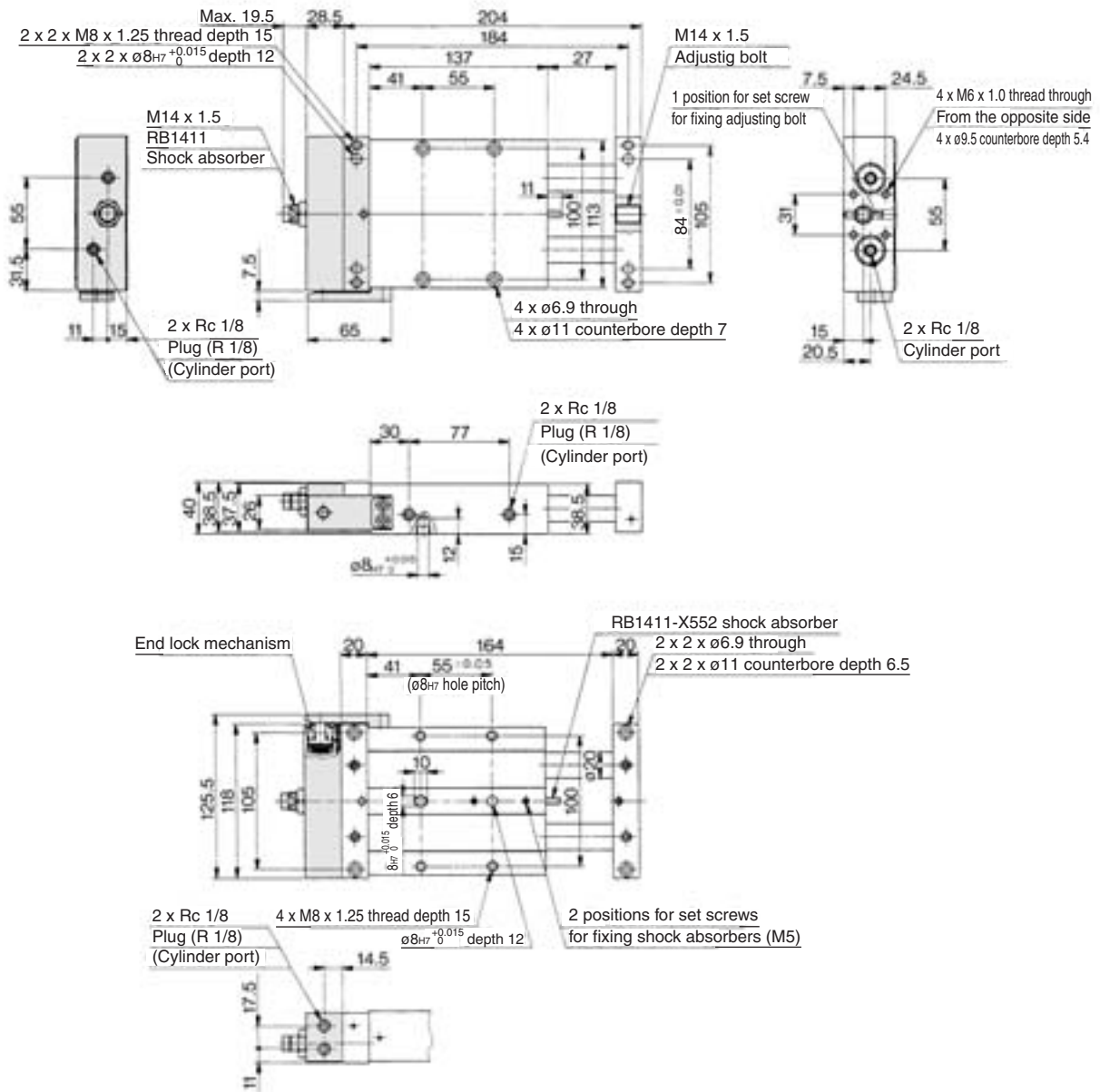

Housing mounting style with auto switch CDBXWL32-25, CDBXWL32-25R

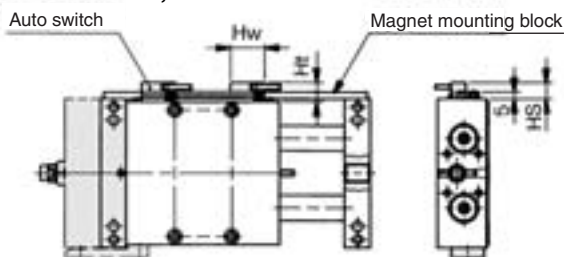

Note 1) The dimensions show D-A7 and D-A8. (mm)

| Auto switch model | Hw | Hs | Ht |
|--|----|------|------|
| D-A7□, D-A80 | 23 | 12.5 | 15 |
| D-F7□, D-J79, D-J79W, D-F7□W, D-F79F, D-F7BAL, D-F7NTL | 23 | 12.5 | 15 |
| D-A7□H, D-A80H | 22 | 12.5 | 15 |
| D-A73C, D-A80C | 23 | 15 | 17.5 |
| D-F7□V, D-F7□WV, D-F7BAV | 23 | 12.5 | 15 |
| D-J79C | 24 | 15 | 17.5 |
| D-F7LF | 30 | 12.5 | 15 |

Note 2) 2 magnets for auto switches are equipped to the magnet mounting block.

Plate mounting style with auto switch CDPXWL32-25, CDPXWL32-25R

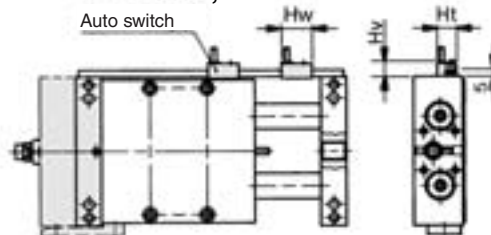

Note 1) The dimensions show D-A7 and D-A8. (mm)

| Auto switch model | Hw | Ht | Hv |
|--|----|------|------|
| D-A7□, D-A80 | 23 | 15 | 10.5 |
| D-F7□, D-J79, D-J79W, D-F7□W, D-F79F, D-F7BAL, D-F7NTL | 23 | 15 | 10 |
| D-A7□H, D-A80H | 22 | 15 | 9 |
| D-A73C, D-A80C | 23 | 17.5 | 17.5 |
| D-F7□V, D-F7□WV, D-F7BAV | 23 | 15 | 14 |
| D-J79C | 24 | 17.5 | 16 |

Note 2) 2 magnets for auto switches are installed in the housing.

Operating Range

(mm)

| Auto switch model | | Applicable cylinder size | | | | |
|--|------------------|--------------------------|----|-----|----|-----|
| | | 10 | 16 | 20 | 25 | 32 |
| D-A7□/A80 D-A7□H/A80H D-A73C/A80C | Housing mounting | — | 6 | 6 | 6 | 6 |
| | Plate mounting | 6 | | | | |
| D-E7□A/E80A | Housing mounting | 6 | — | — | — | — |
| D-F7□/J79 D-F7□V/J79C D-F7□W/F7□WV D-F7BAL/F7BAVL D-F79F/F7NTL | Housing mounting | — | 4 | 2.5 | 3 | 3 |
| | Plate mounting | 3 | 3 | | | 2.5 |

* Since this is a guideline including hysteresis, not meant to be guaranteed.
(Assuming approximately ±30% dispersion)
There may be the case it will vary substantially depending on an ambient environment.

Other than the applicable auto switches listed in “How to Order”, the following auto switches can be mounted.
For detailed specifications, refer to pages 1719 to 1827.

| Auto switch type | Model | Electrical entry (Fetching direction) | Features | Applicable cylinder size | |
|--------------------|---------|--|------------|--------------------------|-----------------------------|
| | | | | Housing mounting | Plate mounting |
| Solid state | D-F7NTL | Grommet (In-line) | With timer | ø16, ø20 ø25, ø32 | ø10, ø16 ø20, ø25 ø32 |

* With pre-wire connector is available for D-F7NTL type, too. For details, refer to pages 1784 and 1785.
* It is impossible to mount solid state auto switches to the housing mounting ø10.

CX2

CXW

CXT

CXSJ

CXS

D-□

-X□

Individual
-X□



Series CXW Specific Product Precautions 1

Be sure to read before handling. Refer to front matters 42 and 43 for Safety Instructions and pages 3 to 11 for Actuator and Auto Switch Precautions.

⚠ Warning

1. Take precautions to prevent your fingers or hands from getting caught between the plate and the housing.
 - Take sufficient care to avoid getting your hands or fingers caught when the cylinder is operated.

⚠ Caution

1. Make sure that the cylinder mounting surface is flat (a flatness of 0.05 or less {reference value}).
If it is not flat, it could lead to malfunction.
2. Make sure not to scratch or gouge the cylinder mounting surface.
Be aware that if the flatness of the housing mounting surface or the mounting surface of the plates on both sides is affected, it could lead to a malfunction.
3. Be careful not to twist the two piston rods.
If the piston rods are twisted or bent when mounting the housing, the operating resistance could become abnormally high or the bearings could wear prematurely, leading to reduced accuracy or air leakage.
4. Consider reinforcing the plates.
When the cylinder is mounted on the housing, and the plates are used for high-speed operation or used as a pusher, use a connector plate to bridge both plates. Failure to do so could cause the snap ring to become detached or the set screws to shift, causing the plates to fall off.

Recommended Pneumatic Circuit

⚠ Caution

1. This is necessary for the proper operation and release of the lock for cylinders with an end lock.

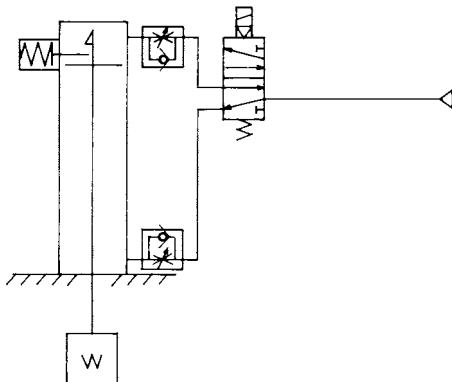

Precautions for Handling the End Lock Mechanism

⚠ Caution

1. Do not use 3 position solenoid valves.
Avoid using this cylinder in combination with a 3 position solenoid valve (particularly the closed center metal seal type). If air pressure becomes sealed inside the port of the side that contains the lock mechanism, the lock will not engage. Even if the lock is engaged at first, the air that leaks from the solenoid valve could enter the cylinder and cause the lock to disengage as time elapses.
2. Back pressure is required to release the end lock.
Be sure that air is supplied to the cylinder side without the locking mechanism (For cylinders with a double lock, the side with an unlocked piston rod) before starting operating, as shown in the drawing on the left. The lock may not be released. (Refer to the section on releasing the lock.)
3. Disengage the lock before installing or adjusting the cylinder.
The lock could become damaged if the cylinder is installed with its lock engaged.
4. Operate with a load ratio of 50% or less.
If the load ratio exceeds 50%, this may cause problems such as failure of the lock to release, or damage to the lock unit.
5. Do not operate multiple cylinders in synchronization.
Avoid applications in which two or more end lock cylinders are synchronized to move one workpiece, as one of the cylinder locks may not be able to release when required.
6. Use a speed controller with meter-out control.
Lock cannot be released occasionally by meter-in control.
7. Adjust the stroke within the range of the slotted hole of the lock finger.
As the hole for mounting the lock finger is slotted, the lock finger may be adjusted and mounted in accordance with the adjustment amount of the adjusting bolt. The adjustment amount of the adjusting bolt is ± 2 mm (± 1 mm for each side).
8. Regarding manual disengagement
Insert a Phillips screwdriver through the lock finger hole to push the lock piston down and slide it in the unlocking direction. When doing so, take precautions to prevent your fingers or hands from getting caught between the housing plate and the lock.

Operating Pressure

⚠ Caution

1. Apply a pressure more than the minimum operating pressure to the port on the side where the locking mechanism activates. The pressure is necessary to release the lock.

Releasing the Lock

⚠ Warning

1. Before releasing the lock, be sure to supply air to the side without the lock mechanism, so that there is no load applied to the lock mechanism when it is released. (Refer to the recommended pneumatic circuit.) If the lock is released when the port on the other side is in an exhaust state, and with a load applied to the lock unit, the lock unit may be subjected to an excessive force and be damaged. Furthermore, sudden movement of the piston rod is extremely dangerous.



Series CXW Specific Product Precautions 2

Be sure to read before handling. Refer to front matters 42 and 43 for Safety Instructions and pages 3 to 11 for Actuator and Auto Switch Precautions.

Handling on Shock Absorber

⚠ Caution

1. Use caution not to be exposed to cutting oil, water, or dust, etc.

The RB series cannot be used under conditions in which fluids such as cutting oil or water are present in atomized form or come in direct contact with the piston rod, or in which dust could adhere to the piston rod. Such conditions would cause malfunction.

2. Do not operate the shock absorber in an environment that poses the risk of corrosion.

The shock absorber could rust if used in an environment that poses the risk of corrosion.

Refer to the respective construction for type of material that is used in the shock absorber.

3. Abide by the table below for the tightening torque for a mounting nut.

| Shock absorber model | RB0805 | RB1006 | RB1411 |
|--------------------------------|-------------------------------------|-------------------------------------|------------------------------------|
| Applicable slide unit | CXWM ₁₀ ⁰ -25 | CXWM ₂₀ ⁰ -25 | CXWM32-25, 50 CXWL32-25 |
| Thread O.D. (mm) | M8 x 1.0 | M10 x 1.0 | M14 x 1.5 |
| Thread prepared hole size (mm) | ø7.1 ^{+0.1} ₀ | ø9.1 ^{+0.1} ₀ | ø12.7 ^{+0.1} ₀ |
| Tightening torque (N·m) | 1.67 | 3.14 | 10.8 |

4. Do not scratch the sliding portion of the piston rod or the outside threads of the outer tube.

Do not scratch or gouge the sliding portion of the piston rod or the outside threads of the outer tube by striking it with an object, squeezing it, or by forcefully wedging a set screw in it.

Failure to observe this precaution could damage the seals, which could lead to oil leakage and malfunction. Furthermore, scratches or gouges on the outside threads of the outer tube could prevent the shock absorber from being mounted onto the frame, or its internal components could deform, leading to a malfunction.

5. Never turn the screw on the bottom of the body.

(This is not an adjusting screw.)

Turning it could cause oil leakage.

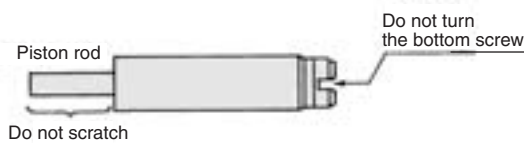

6. Check the mounting nut is not loosen.

The shock absorber could become damaged if it is used in a loose state.

7. Pay attention to any abnormal impact sounds or vibrations.

If the impact sounds or vibrations have become abnormally high, the shock absorber may have reached the end of its service life. If this is the case, replace the shock absorber.

If use is continued in this state, it could damage the equipment to which the shock absorber is mounted.

8. Refer to the Instruction Manual for how to replace the built-in shock absorber for the CXW series.

Service Life and Replacement Period of Shock Absorber

⚠ Caution

1. Allowable operating cycle under the specifications set in this catalog is shown below.

1.2 million cycles RB08□□

2 million cycles RB10□□ to RB2725

Note) Specified service life (suitable replacement period) is the value at room temperature (20 to 25°C). The period may vary depending on the temperature and other conditions. In some cases the absorber may need to be replaced before the allowable operating cycle above.

Auto Switch Selection for the Adjustable Stroke Type (-X138)

⚠ Caution

1. When 50 stroke is adjusted to 40 stroke or less with the adjustable stroke type (-X138), auto switches may not be able to be mounted properly since they interfere with each other if the 2 in-line entry auto switches are used.

When strokes are adjusted to 40 stroke or less, select the perpendicular entry type or additionally select auto switches with 2 built-in magnets (-X169).

CX2

CXW

CXT

CXSJ

CXS

D-□

-X□

Individual
-X□