

# S Couplers

## Series KKA

### Stainless steel type



- **Body material: Stainless steel 304**  
**Seal material: Fluoro rubber (Special FKM)**
- **Both plug and socket have an integral check valve.**  
Available with and without check valves depending on the operating conditions.
- **Reduces liquid dripping when the plug and socket are uncoupled.**  
Liquid dripping: 0.02 to 0.77 cm<sup>3</sup> at each removal  
Aeration: 0.1 to 2.7 cm<sup>3</sup> at each removal

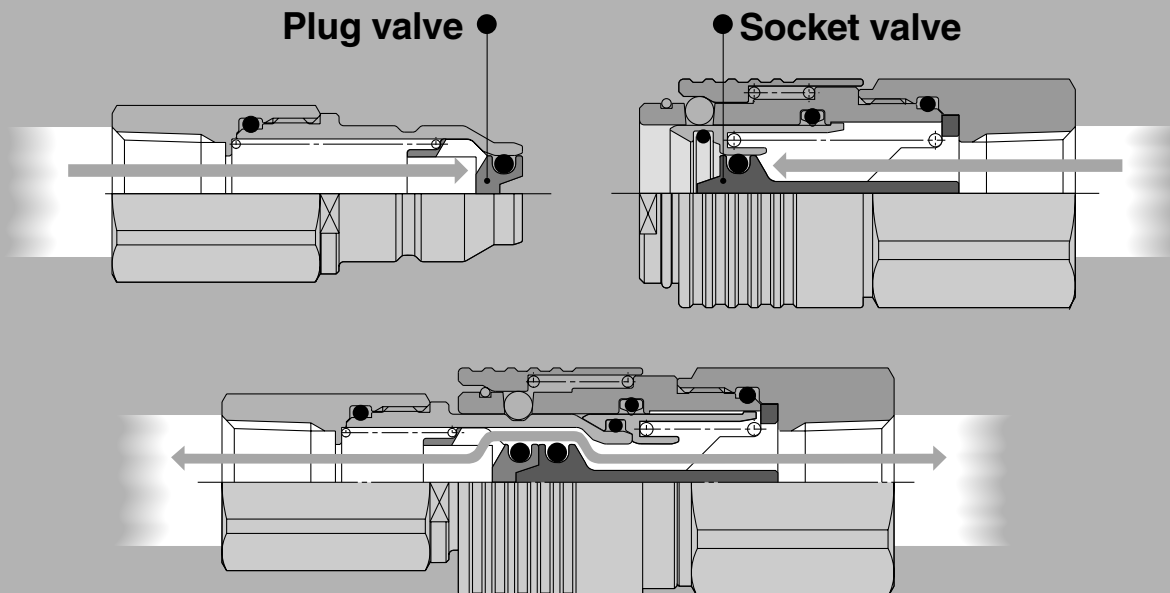

- **Non-greased specification (standard)**  
Allows smooth installation and removal even without grease
  - O-ring: Fluorine coated
  - Sliding parts of plug and socket: Plated with fluorine-contained material
- **Fluid: Water, Air**
- **Operating temperature range: -5 to 150°C**  
Note) This product should not be used with steam.

K

M

H

**KK**

D

MS

LQ



MQR

T

# Series KKA

## Plug (P)

### Male thread type



	Body size	Port size	Part no.	
			With check valve	Without check valve
	1/8	R 1/8	<b>KKA3P-01M</b>	<b>KKA3P-01M-1</b>
		R 1/4	<b>-02M</b>	<b>-02M-1</b>
		R 3/8	<b>-03M</b>	<b>-03M-1</b>
	1/4	R 1/4	<b>KKA4P-02M</b>	<b>KKA4P-02M-1</b>
		R 3/8	<b>-03M</b>	<b>-03M-1</b>
		R 1/2	<b>-04M</b>	<b>-04M-1</b>
	1/2	R 3/8	<b>KKA6P-03M</b>	<b>KKA6P-03M-1</b>
		R 1/2	<b>-04M</b>	<b>-04M-1</b>
		R 3/4	<b>-06M</b>	<b>-06M-1</b>
	3/4	R 1/2	<b>KKA7P-04M</b>	—
		R 3/4	<b>-06M</b>	—
		R 1	<b>-10M</b>	—
	1	R 3/4	<b>KKA8P-06M</b>	—
		R 1	<b>-10M</b>	—
		R 1 1/4	<b>-12M</b>	—
	1 1/4	R 1	<b>KKA9P-10M</b>	—
		R 1 1/4	<b>-12M</b>	—
		R 1 1/2	<b>-14M</b>	—

## Socket (S)

### Male thread type

	Body size	Port size	Part no.	
			With check valve	Without check valve
	1/8	R 1/8	<b>KKA3S-01M</b>	<b>KKA3S-01M-1</b>
		R 1/4	<b>-02M</b>	<b>-02M-1</b>
		R 3/8	<b>-03M</b>	<b>-03M-1</b>
	1/4	R 1/4	<b>KKA4S-02M</b>	<b>KKA4S-02M-1</b>
		R 3/8	<b>-03M</b>	<b>-03M-1</b>
		R 1/2	<b>-04M</b>	<b>-04M-1</b>
	1/2	R 3/8	<b>KKA6S-03M</b>	<b>KKA6S-03M-1</b>
		R 1/2	<b>-04M</b>	<b>-04M-1</b>
		R 3/4	<b>-06M</b>	<b>-06M-1</b>
	3/4	R 1/2	<b>KKA7S-04M</b>	—
		R 3/4	<b>-06M</b>	—
		R 1	<b>-10M</b>	—
	1	R 3/4	<b>KKA8S-06M</b>	—
		R 1	<b>-10M</b>	—
		R 1 1/4	<b>-12M</b>	—
	1 1/4	R 1	<b>KKA9S-10M</b>	—
		R 1 1/4	<b>-12M</b>	—
		R 1 1/2	<b>-14M</b>	—

### Female thread type

	Body size	Port size	Part no.	
			With check valve	Without check valve
	1/8	Rc 1/8	<b>KKA3P-01F</b>	<b>KKA3P-01F-1</b>
		Rc 1/4	<b>-02F</b>	<b>-02F-1</b>
		Rc 3/8	<b>-03F</b>	<b>-03F-1</b>
	1/4	Rc 1/4	<b>KKA4P-02F</b>	<b>KKA4P-02F-1</b>
		Rc 3/8	<b>-03F</b>	<b>-03F-1</b>
		Rc 1/2	<b>-04F</b>	<b>-04F-1</b>
	1/2	Rc 3/8	<b>KKA6P-03F</b>	<b>KKA6P-03F-1</b>
		Rc 1/2	<b>-04F</b>	<b>-04F-1</b>
		Rc 3/4	<b>-06F</b>	<b>-06F-1</b>
	3/4	Rc 1/2	<b>KKA7P-04F</b>	—
		Rc 3/4	<b>-06F</b>	—
		Rc 1	<b>-10F</b>	—
	1	Rc 3/4	<b>KKA8P-06F</b>	—
		Rc 1	<b>-10F</b>	—
		Rc 1 1/4	<b>-12F</b>	—
	1 1/4	Rc 1	<b>KKA9P-10F</b>	—
		Rc 1 1/4	<b>-12F</b>	—
		Rc 1 1/2	<b>-14F</b>	—

### Female thread type

	Body size	Port size	Part no.	
			With check valve	Without check valve
	1/8	Rc 1/8	<b>KKA3S-01F</b>	<b>KKA3S-01F-1</b>
		Rc 1/4	<b>-02F</b>	<b>-02F-1</b>
		Rc 3/8	<b>-03F</b>	<b>-03F-1</b>
	1/4	Rc 1/4	<b>KKA4S-02F</b>	<b>KKA4S-02F-1</b>
		Rc 3/8	<b>-03F</b>	<b>-03F-1</b>
		Rc 1/2	<b>-04F</b>	<b>-04F-1</b>
	1/2	Rc 3/8	<b>KKA6S-03F</b>	<b>KKA6S-03F-1</b>
		Rc 1/2	<b>-04F</b>	<b>-04F-1</b>
		Rc 3/4	<b>-06F</b>	<b>-06F-1</b>
	3/4	Rc 1/2	<b>KKA7S-04F</b>	—
		Rc 3/4	<b>-06F</b>	—
		Rc 1	<b>-10F</b>	—
	1	Rc 3/4	<b>KKA8S-06F</b>	—
		Rc 1	<b>-10F</b>	—
		Rc 1 1/4	<b>-12F</b>	—
	1 1/4	Rc 1	<b>KKA9S-10F</b>	—
		Rc 1 1/4	<b>-12F</b>	—
		Rc 1 1/2	<b>-14F</b>	—

# S Couplers Series KKA

Stainless steel type



## JIS Symbol

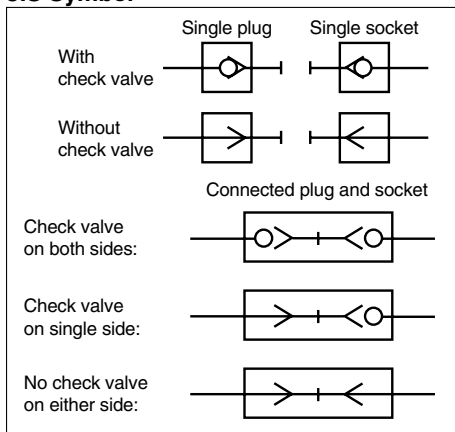

## Characteristics with check valve on both sides

Body size	Liquid dripping cm <sup>3</sup> at each removal	Aeration cm <sup>3</sup> at each removal
KKA3	0.02	0.1
KKA4	0.04	0.1
KKA6	0.06	0.2
KKA7	0.14	0.5
KKA8	0.27	0.9
KKA9	0.77	2.7

### Liquid dripping:

Volume of water leakage at the time when the plug and socket are uncoupled.

### Aeration:

Volume of external air entrained when the plug and socket are connected.

## Specifications

Fluid	Water, Air
Operating pressure range <small>Note 1)</small>	KKA3: -100 kPa to 1 MPa KKA4/6/7/8/9: 0 to 1 MPa
Proof pressure	10 MPa
Ambient and fluid temperature	-5 to 150°C (No freezing) <small>Note 2)</small> This product should not be used with steam.
Non-greased specification	No grease is used. Rubber: Fluorine coated, (Metal sliding parts: Plated with fluorine-contained material)
Material	Metal part: Stainless steel 304, Rubber material: Fluoro rubber (Special FKM)
Seal	With male thread sealant

Note 1) Do not use the S couplers with a leak tester or for vacuum retention because they are not guaranteed for zero leakage.  
Note 2) When fluid contains copper ions, please use KKA□-X70. (p. 275)

## Performance

Plug and socket connection	One-touch connection and release
Check valve	Check valve on both sides, Without check valve

Note) Series KKA cannot be connected with Series KK or Series KKH.

## Effective Area

	Built-in check valve	Plug	Socket	Effective area mm <sup>2</sup>
Plug: With check valve Socket: With check valve		KKA3P-01F	KKA3S-01F	17.4
		KKA4P-02F	KKA4S-02F	26.4
		KKA6P-04F	KKA6S-04F	54.2
		KKA7P-06F	KKA7S-06F	99.6
		KKA8P-10F	KKA8S-10F	168.3
		KKA9P-12F	KKA9S-12F	332.1
Plug: Without check valve Socket: With check valve		KKA3P-01M-1	KKA3S-01M	18.5
		KKA4P-02M-1	KKA4S-02M	31.8
		KKA6P-04M-1	KKA6S-04M	55.3
Plug: Without check valve Socket: Without check valve		KKA3P-01M-1	KKA3S-01M-1	22.6
		KKA4P-02M-1	KKA4S-02M-1	40.2
		KKA6P-04M-1	KKA6S-04M-1	76.0

## How to Order

**KKA 4 P - 02 M**

**Body size**

3	1/8
4	1/4
6	1/2
7	3/4
8	1
9	1 1/4

**Socket/Plug designation**

P	Plug
S	Socket

**Port size**

Symbol	Thread size
01	R, Rc 1/8
02	R, Rc 1/4
03	R, Rc 3/8
04	R, Rc 1/2
06	R, Rc 3/4
10	R, Rc 1
12	R, Rc 1 1/4
14	R, Rc 1 1/2

**Built-in check valve**

Nil	With check valve
-1	Without check valve

Note) KKA7/8/9 is not available without a check valve. Contact us when such a type is needed.

**Connection type**

Symbol	Type
M	Male thread (with sealant)
F	Female thread

	Plug	Socket	Availability
Built-in check valve	Yes	Yes	○
	No	Yes	○
	No	No	○
	Yes	No	×

Note) A plug with check valve should be used in combination with a socket with check valve.  
If a socket without check valve is used, the check valve of the plug will not open.

# Series KKA

## Flow Characteristics

Air

Plug: With check valve Socket: With check valve

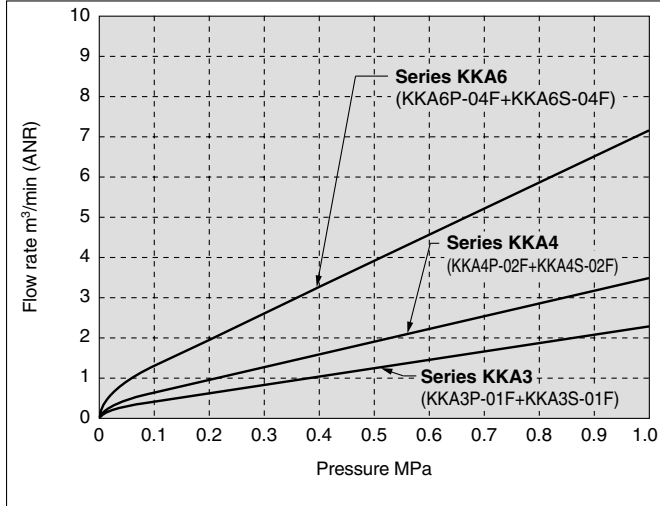

Plug: With check valve Socket: With check valve

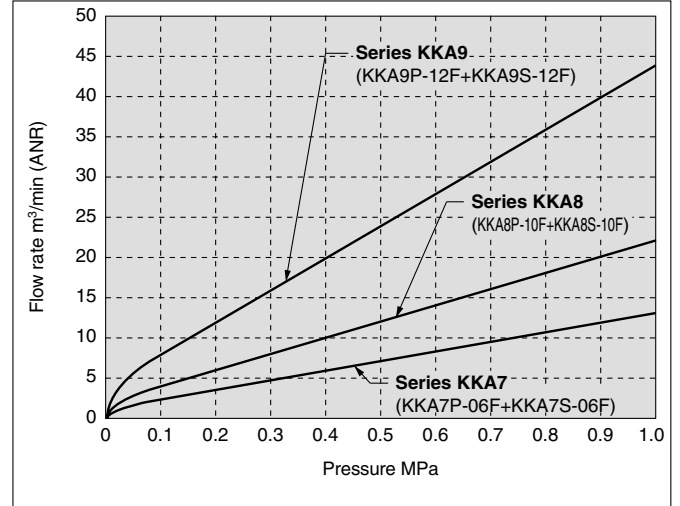

Plug: Without check valve Socket: With check valve

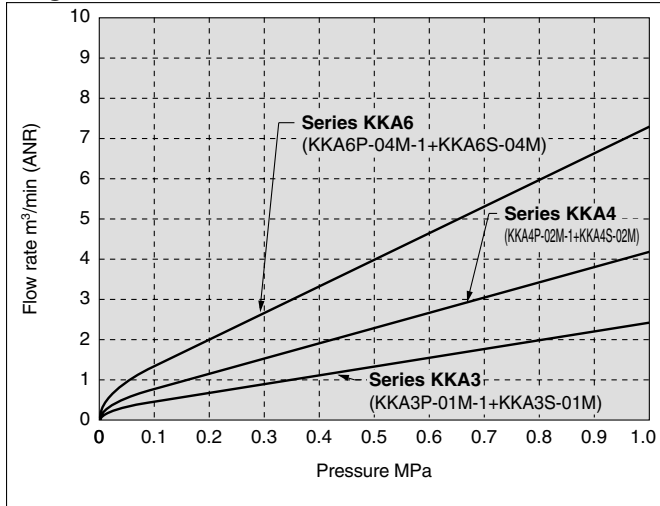

Plug: Without check valve Socket: Without check valve

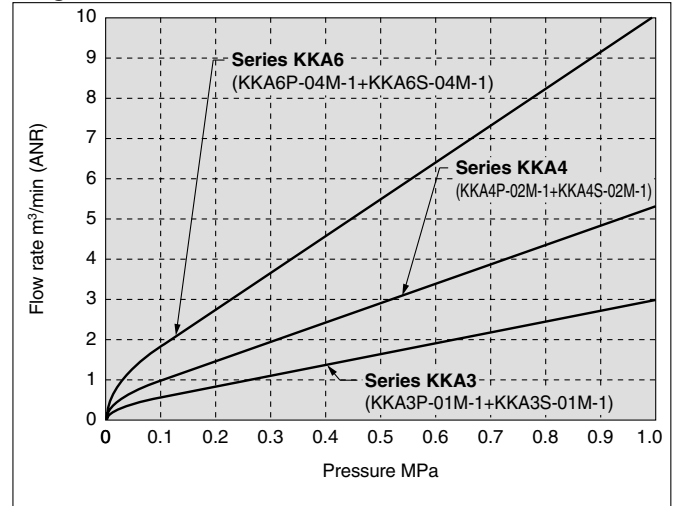

## Pressure Loss

Water

Plug: With check valve Socket: With check valve

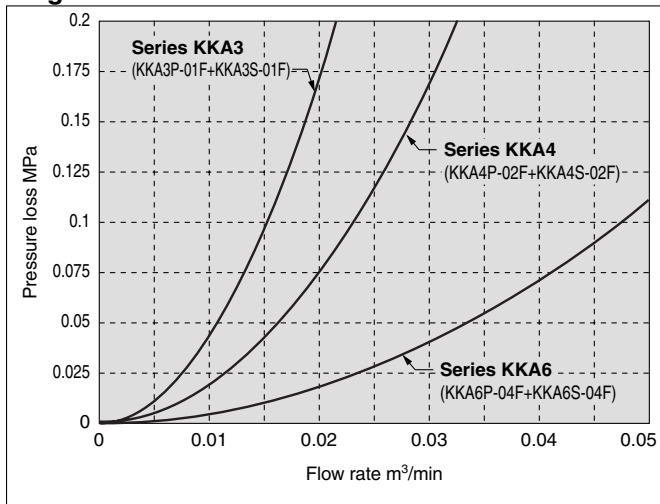

Plug: With check valve Socket: With check valve

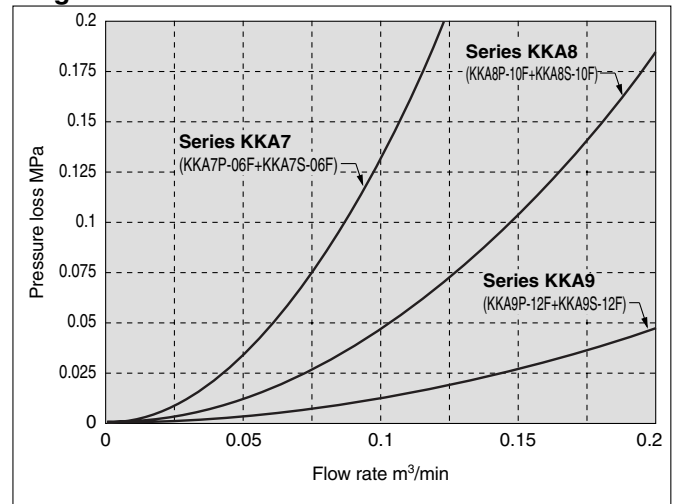

## Construction

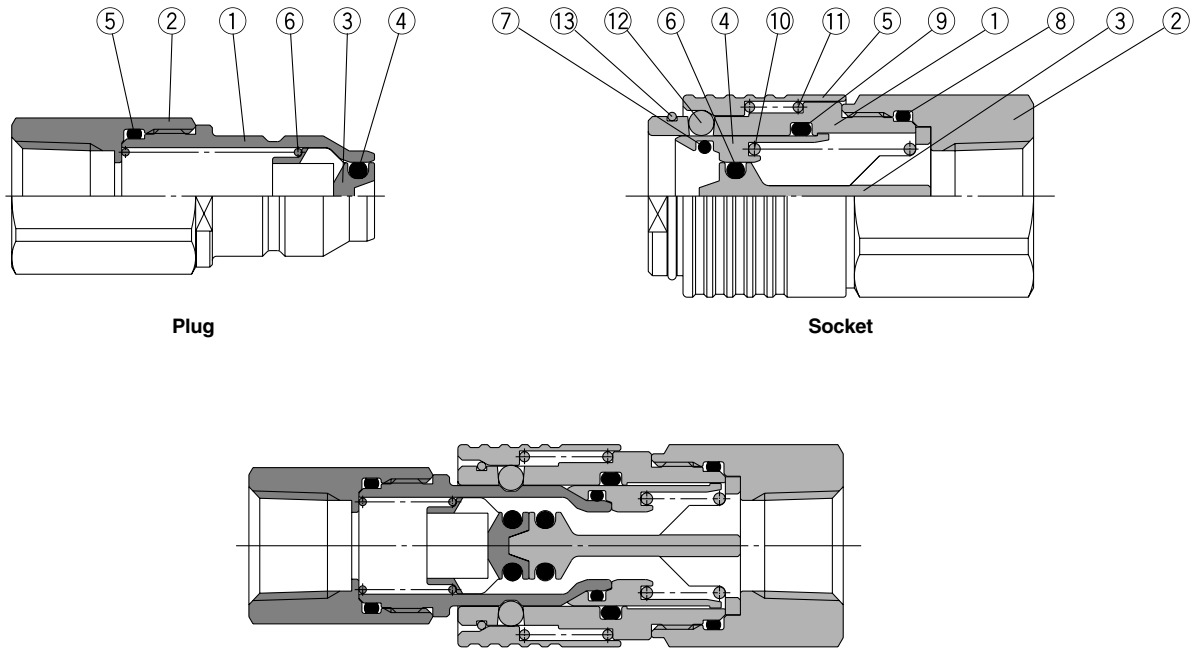

- K
- M
- H
- KKA
- D
- MS
- LQ
- MQR
- T

### Plug

No.	Description	Material	Note
1	<b>Stem</b>	Stainless steel 304	Plated with fluorine-contained material
2	<b>Rear stem</b>	Stainless steel 304	
3	<b>Plug valve</b>	Stainless steel 304	
4	<b>Valve O-ring</b>	Special FKM	Fluorine coated
5	<b>Stem O-ring</b>	Special FKM	Fluorine coated
6	<b>Plug valve spring</b>	Stainless steel 304	

### Socket

No.	Description	Material	Note
1	<b>Body</b>	Stainless steel 304	Plated with fluorine-contained material
2	<b>Rear body</b>	Stainless steel 304	
3	<b>Socket valve</b>	Stainless steel 304	
4	<b>Collar</b>	Stainless steel 304	Plated with fluorine-contained material
5	<b>Sleeve</b>	Stainless steel 304	Plated with fluorine-contained material
6	<b>Valve O-ring</b>	Special FKM	Fluorine coated
7	<b>Plug O-ring</b>	Special FKM	Fluorine coated
8	<b>Body O-ring</b>	Special FKM	Fluorine coated
9	<b>Collar seal</b>	Special FKM	Fluorine coated
10	<b>Collar spring</b>	Stainless steel 304	
11	<b>Sleeve spring</b>	Stainless steel 304	
12	<b>Steel ball</b>	Stainless steel 304	
13	<b>Stopper ring</b>	Stainless steel 304	

### Series KKA Spare Parts

Description	Product no.	No.
Plug O-ring	KKA3S-P01	Socket ⑦
	KKA4S-P01	
	KKA6S-P01	
	KKA7S-P01	
	KKA8S-P01	
	KKA9S-P01	

# Series KKA

## Dimensions/Plug (P)

With check valve

Male thread type

(mm)



Body size	Model	T Connection port size	H Width across flats	L1	L2	A	Min. bore size	Effective area mm <sup>2</sup>	Mass g
1/8	KKA3P-01M	R 1/8	14	35.4	16.0	31.4	5.6	17.4	15.4
	-02M	R 1/4		38.4		32.4			19.8
	-03M	R 3/8		39.4		32.9			32.9
1/4	KKA4P-02M	R 1/4	17	42.2	18.9	36.2	6.9	26.4	28.3
	-03M	R 3/8		43.2		36.7			36.6
	-04M	R 1/2	22	46.2		38.2			65.9
1/2	KKA6P-03M	R 3/8	24	47.1	20.4	40.6	10.0	54.2	60.3
	-04M	R 1/2		47.9		39.9			69.2
	-06M	R 3/4	30	49.9		40.4			119.0
3/4	KKA7P-04M	R 1/2	32	66.3	27.6	58.1	13.5	99.6	173.9
	-06M	R 3/4		69.4		59.9			209.6
	-10M	R 1	36	69.9		59.5			275.0
1	KKA8P-06M	R 3/4	41	82.9	35.6	73.4	17.5	168.3	362.8
	-10M	R 1		85.4		75.0			403.9
	-12M	R 1 1/4	46	85.4		72.7			538.6
1 1/4	KKA9P-10M	R 1	55	109.5	49.1	99.1	22.0	264.9	824.1
	-12M	R 1 1/4		109.0		96.3			861.4
	-14M	R 1 1/2		109.0		96.3	24.6	332.1	936.3

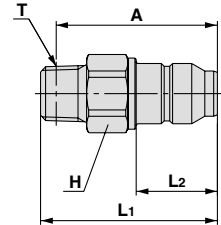

Female thread type

(mm)



Body size	Model	T Connection port size	H Width across flats	L1	L2	Min. bore size	Effective area mm <sup>2</sup>	Mass g
1/8	KKA3P-01F	Rc 1/8	14	36.0	16.0	5.6	17.4	20.2
	-02F	Rc 1/4	17	39.6				31.8
	-03F	Rc 3/8	19	40.4				35.8
1/4	KKA4P-02F	Rc 1/4	17	43.4	18.9	6.9	26.4	36.1
	-03F	Rc 3/8	19	44.4				40.2
	-04F	Rc 1/2		48.6				69.7
1/2	KKA6P-03F	Rc 3/8	24	48.7	20.4	10.0	54.2	84.1
	-04F	Rc 1/2		52.9				79.7
	-06F	Rc 3/4	30	54.6				123.8
3/4	KKA7P-04F	Rc 1/2	32	67.7	27.6	13.5	99.6	217.1
	-06F	Rc 3/4		69.4				196.8
	-10F	Rc 1		72.4				325.9
1	KKA8P-06F	Rc 3/4	41	82.0	35.6	17.5	168.3	420.5
	-10F	Rc 1		85.0				391.3
	-12F	Rc 1 1/4	50	87.3				552.8
1 1/4	KKA9P-10F	Rc 1	55	107.8	49.1	24.6	332.1	986.9
	-12F	Rc 1 1/4		110.1				925.6
	-14F	Rc 1 1/2		110.1				848.2

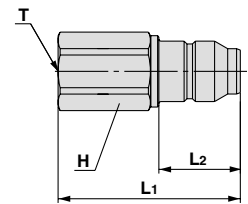

## Dimensions/Socket (S)

With check valve

Male thread type

(mm)



Body size	Model	T Connection port size	H Width across flats	øD	L	A	Min. bore size	Effective area mm <sup>2</sup>	Mass g
1/8	KKA3S-01M	R 1/8	17	18.5	38.1	34.1	5.9	18.5	38.5
	-02M	R 1/4			41.1	35.1			41.8
	-03M	R 3/8			42.1	35.6			46.3
1/4	KKA4S-02M	R 1/4	22	24.2	46.0	40.0	7.7	31.8	76.8
	-03M	R 3/8			47.0	40.5			78.5
	-04M	R 1/2			50.0	42.0			86.6
1/2	KKA6S-03M	R 3/8	30	30.7	51.4	44.9	10.2	55.3	149.1
	-04M	R 1/2			54.4	46.4			160.4
	-06M	R 3/4			56.4	46.9			184.8
3/4	KKA7S-04M	R 1/2	36	42.5	76.3	68.1	13.6	101.5	426.1
	-06M	R 3/4			79.3	69.8			457.8
	-10M	R 1			82.8	72.4			514.0
1	KKA8S-06M	R 3/4	46	55	94.9	85.4	17.6	169.9	873.5
	-10M	R 1			98.4	88.0			931.1
	-12M	R 1 1/4			100.4	87.7			1012.9
1 1/4	KKA9S-10M	R 1	63	69	125.5	115.1	25.1	344.9	1680.7
	-12M	R 1 1/4			127.5	114.8			1758.1
	-14M	R 1 1/2			127.5	114.8			1819.4

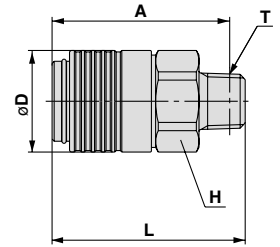

- K
- M
- H
- KK
- D
- MS
- LQ
- MQR
- T

Female thread type

(mm)



Body size	Model	T Connection port size	H Width across flats	øD	L	Min. bore size	Effective area mm <sup>2</sup>	Mass g
1/8	KKA3S-01F	Rc 1/8	17	18.5	37.6	5.9	18.5	46.9
	-02F	Rc 1/4			41.2			47.2
	-03F	Rc 3/8			43.1			52.3
1/4	KKA4S-02F	Rc 1/4	22	24.2	46.1	7.7	31.8	97.1
	-03F	Rc 3/8			46.9			91.1
	-04F	Rc 1/2			52.3			104.3
1/2	KKA6S-03F	Rc 3/8	30	30.7	50.5	10.2	55.3	189.6
	-04F	Rc 1/2			56.2			202.0
	-06F	Rc 3/4			57.9			180.6
3/4	KKA7S-04F	Rc 1/2	36	42.5	75.1	13.6	101.5	477.2
	-06F	Rc 3/4			76.5			457.4
	-10F	Rc 1			82.3			550.9
1	KKA8S-06F	Rc 3/4	46	55	90.9	17.6	169.9	935.2
	-10F	Rc 1			93.9			914.7
	-12F	Rc 1 1/4			99.2			1002.1
1 1/4	KKA9S-10F	Rc 1	63	69	121.8	25.1	344.9	1919.1
	-12F	Rc 1 1/4			121.8			1810.0
	-14F	Rc 1 1/2			121.8			1732.6

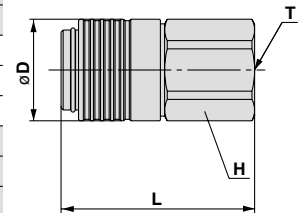

# Series KKA

## Dimensions/Plug (P)

Without check valve

Male thread type

(mm)



Body size	Model	T Connection port size	H Width across flats	L1	L2	A	Min. bore size	Effective area mm <sup>2</sup>	Mass g
1/8	KKA3P-01M-1	R 1/8	12	28.5	16.0	24.5	6.0	22.6	9.8
	-02M-1	R 1/4	14	31.5		25.5			14.6
	-03M-1	R 3/8	17	32.5		26.0			23.6
1/4	KKA4P-02M-1	R 1/4	17	34.4	18.9	28.4	8.0	40.2	21.0
	-03M-1	R 3/8		35.4		28.9			27.9
	-04M-1	R 1/2		39.4		31.4			50.2
1/2	KKA6P-03M-1	R 3/8	22	37.9	20.4	31.4	11.0	76.0	41.9
	-04M-1	R 1/2	40.9	32.9		56.0			
	-06M-1	R 3/4	30	42.9		33.4			98.7

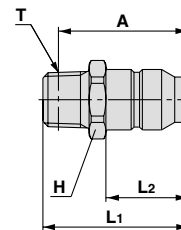

Female thread type

(mm)



Body size	Model	T Connection port size	H Width across flats	L1	L2	Min. bore size	Effective area mm <sup>2</sup>	Mass g
1/8	KKA3P-01F-1	Rc 1/8	14	23.2	16.0	6.0	22.6	9.6
	-02F-1	Rc 1/4	17	30.3				20.2
	-03F-1	Rc 3/8	19	32.0				26.2
1/4	KKA4P-02F-1	Rc 1/4	17	29.7	18.9	8.0	40.2	20.0
	-03F-1	Rc 3/8	19	34.0				25.8
	-04F-1	Rc 1/2	24	39.4				46.1
1/2	KKA6P-03F-1	Rc 3/8	22	30.9	20.4	11.0	76.0	34.3
	-04F-1	Rc 1/2	24	39.6				50.0
	-06F-1	Rc 3/4	30	42.8				78.6

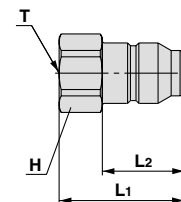

## Dimensions/Socket (S)

Without check valve

Male thread type

(mm)



Body size	Model	T Connection port size	H Width across flats	øD	L	A	Min. bore size	Effective area mm <sup>2</sup>	Mass g
1/8	KKA3S-01M-1	R 1/8	17	18.5	38.1	34.1	6.1	23.4	36.1
	-02M-1	R 1/4			41.1	35.1			39.4
	-03M-1	R 3/8			42.1	35.6			43.9
1/4	KKA4S-02M-1	R 1/4	22	24.2	46.0	40.0	8.1	41.2	71.9
	-03M-1	R 3/8			47.0	40.5			73.6
	-04M-1	R 1/2			50.0	42.0			81.7
1/2	KKA6S-03M-1	R 3/8	30	30.7	51.4	44.9	11.4	81.6	138.3
	-04M-1	R 1/2			54.4	46.4			149.6
	-06M-1	R 3/4			56.4	46.9			174.0

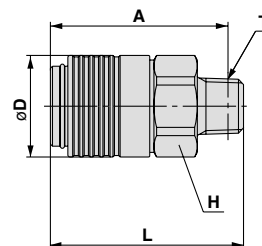

Female thread type

(mm)



Body size	Model	T Connection port size	H Width across flats	øD	L	Min. bore size	Effective area mm <sup>2</sup>	Mass g
1/8	KKA3S-01F-1	Rc 1/8	17	18.5	37.6	6.1	23.4	44.5
	-02F-1	Rc 1/4			41.2			44.8
	-03F-1	Rc 3/8			43.1			49.9
1/4	KKA4S-02F-1	Rc 1/4	22	24.2	46.1	8.1	41.2	92.2
	-03F-1	Rc 3/8			46.9			86.2
	-04F-1	Rc 1/2			52.3			99.4
1/2	KKA6S-03F-1	Rc 3/8	30	30.7	50.5	11.4	81.6	178.8
	-04F-1	Rc 1/2			56.2			191.2
	-06F-1	Rc 3/4			57.9			169.8

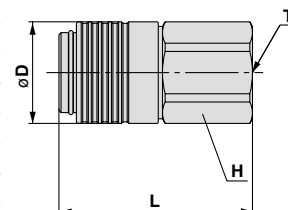



Series **KKA**

# Made to Order Specifications



Please consult SMC for detailed specifications, dimensions and delivery.

**1** Specifications without fluorine coating at the liquid-contact part Symbol  
**-X70**

Ex.) **KKA3S-01M-X70**

• Without fluorine coating at the liquid contact part

- K
- M
- H
- KK**
- D
- MS
- LQ
- MQR
- T

**Refer to pages 182 to 183 for Specific Product Precautions.**