

Floating Joint

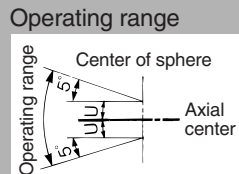

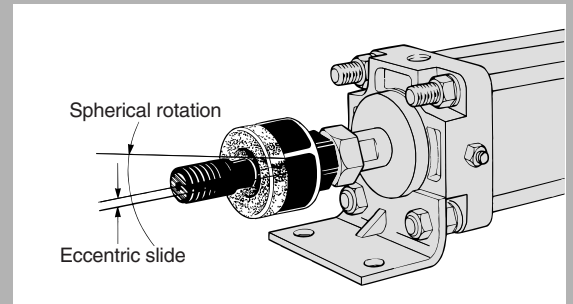

Series JA/JAH/JB/JS

The floating joint can absorb any “off-centering” or “loss of parallel accuracy” between the cylinder and the driven body.

- Centering is unnecessary.
- A high level of machining accuracy is unnecessary.
- The installation time is dramatically reduced.
- It is compact and is suitable for high tensile stresses.
- Long service life (with dustproof cover)
- Rotating angle..... $\pm 5^\circ$



Series Variations

Series	Cylinder supply pressure	Applicable bore size (mm)	Mounting	Page
Standard Series JA 	Pneumatic cylinder	0.7 MPa or less	Basic style Flange style Foot style	908
		1 MPa or less		
	Hydraulic cylinder	3.5 MPa or less	20, 25, 30, 40, 50, 63 80, 100, 125, 140, 160	
Heavy load Series JAH 	Hydraulic cylinder	7 MPa or less	Basic style Flange style Foot style	913
For compact cylinders Series JB 	Pneumatic cylinder	1 MPa or less	Basic style (Female thread)	916
Stainless steel type Series JS 	Pneumatic cylinder	1 MPa or less	Basic style	918
	Hydraulic cylinder	3.5 MPa or less		

J□

D-□

-X□

Individual

-X□

Technical data

Floating Joint: Standard Type

Series JA

Specifications

Operating pressure	Pneumatic cylinder: 1 MPa or less
	Hydraulic cylinder: 3.5 MPa or less
Mounting	Basic style, Flange style, Foot style

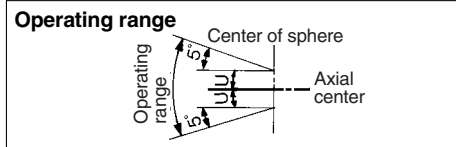

Series JA

⚠ Precautions

Be sure to read before handling.
Refer to front matters 54 and 55 for Safety Instructions.

Mounting

⚠ Warning

- To screw the male threads of the rod into the female threads of the socket or the case, make sure that it does not bottom out. If the floating joint is used with its rod bottom out, the stud will not be able to float, causing damage. For the screw-in depth of the female threads, refer to the dimensions (page 910). As a rule, after the rod bottoms out, back off 1 to 2 turns. The dust cover may be fixed with the stud, so loosen them before using.
- When screwing stud or socket, or case in the driven object, make sure to screw them in the state that dust cover has been removed from the case. If screwing without removing dust cover, duct cover might be broken.
- To use a floating joint to connect the cylinder rod to a driven body, secure it in place by applying a torque that is appropriate for the thread size. Also, if there is a risk of loosening during operation, take measures to prevent loosening, such as using a locking pin or thread adhesive. In the event that the connected portion becomes loose, the driven body might lose control or fall off, leading to equipment damage or injury to personnel.
- Do not use for rotational applications, because it is not a fitting designed for rotational axis.

Maintenance

⚠ Warning

- Do not reuse if disassembled. High strength adhesive is applied to the portion of the connection that is threaded to prevent it from loosening, and it must not be disassembled. If it is forcefully disassembled, it could lead to damage.

Model/Specifications

Model	Applicable bore size (mm)	Applicable cylinder nominal thread size	Maximum operating tension and compression force (N)			Allowable eccentricity U (mm)	Rotating angle
			Basic style	Flange style	Foot style		
Standard/Thread nominal size							
JA6-3-050	6	M3 x 0.5	19	—	—	0.5	±5°
JA10-4-070	10	M4 x 0.7	54	—	—	0.5	
JA15-5-080	10, 15	M5 x 0.8	123	—	—	0.5	
JA15-6-100	15	M6 x 1	123	—	—	0.5	
JA□20-8-125	20	M8 x 1.25	1100	1100	1000*	0.5	
JA□30-10-125	25, 32	M10 x 1.25	2500	2500	2000*	0.5	
JA□40-14-150	40	M14 x 1.5	6000	4400	4400	0.75	
JA□63-18-150	50, 63	M18 x 1.5	11000	11000	9000*	1	
JA□80-22-150	80	M22 x 1.5	18000	18000	14000*	1.25	
JA□100-26-150	100	M26 x 1.5	28000	28000	22000*	2	
JA□140-30-150	125, 140	M30 x 1.5	54000	36000*	36000*	2.5	
JA□160-36-150	160	M36 x 1.5	71000	55000*	55000*	3	
Option/Thread nominal size							
JA□20-8-100	20	M8 x 1	1100	1100	1000*	0.5	±5°
JA□25-10-150	25	M10 x 1.5	2500	2500	2000	0.5	
JA□32-10-100	32	M10 x 1	2500*	2500*	2000*	0.5	
JA□40-12-125	32, 40	M12 x 1.25	4400	4400	4400	0.75	
JA□40-12-150	40	M12 x 1.5	4400	4400	4400	0.75	
JA□40-12-175	32, 40	M12 x 1.75	4400	4400	4400	0.75	
JA□50-16-150	50	M16 x 1.5	11000	11000	9000	1	
JA□63-16-200	50, 63	M16 x 2	11000	11000	9000*	1	
JA□80-20-250	80	M20 x 2.5	18000	18000	14000*	1.25	
JA□100-24-300	100	M24 x 3	28000	28000	22000*	2	
JA□100-27-150	100	M27 x 1.5	28000	28000	22000*	2	
JA□125-27-200	125	M27 x 2	28000*	28000*	28000*	2	
JA□160-33-200	160	M33 x 2	71000	55000*	55000*	3	

* For 3.5 MPa hydraulic cylinders, operate within the maximum tension and compression force.

How to Order

JA **F** **40** - **14-150** - **□**

Mounting style

Nil	Basic style
F	Flange style
L	Foot style

Thread nominal size (Standard)

Nominal thread size	Applicable cylinder nominal thread size
3-050	M3 x 0.5
4-070	M4 x 0.7
5-080	M5 x 0.8
6-100	M6 x 1
8-125	M8 x 1.25
10-125	M10 x 1.25
14-150	M14 x 1.5
18-150	M18 x 1.5
22-150	M22 x 1.5
26-150	M26 x 1.5
30-150	M30 x 1.5
36-150	M36 x 1.5

Option

Nil	None
X11	High temperature specifications -5 to 100°C

Applicable bore size (mm)

Model	Symbol	Applicable bore size (mm)
Standard	6	6
	10	10
	15	10, 15
	20	20
	30	25, 32
	40	40
	63	50, 63
	80	80
	100	100
	140	125, 140
160	160	

Construction

ø6 to ø15

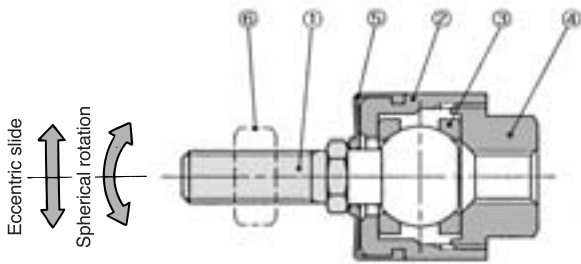

ø20 to ø160

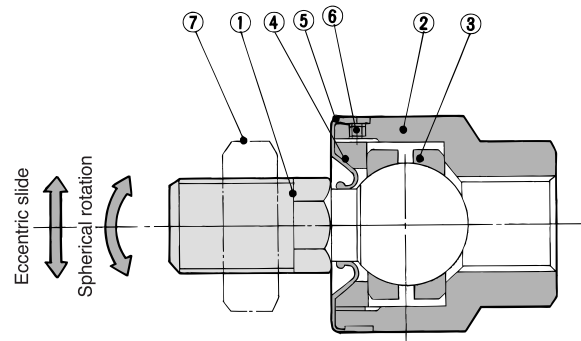

Component Parts

No.	Description	Material	Note
1	Stud	Free-cutting steel	Electroless nickel plated
2	Case	Brass	Electroless nickel plated
3	Ring	Stainless steel	
4	Socket	Brass	Electroless nickel plated
5	Dust cover	Synthetic rubber	
6	Rod end nut	Low carbon steel wire rod	Zinc chromated

No.	Description	Material	Note
1	Stud	Chromium molybdenum steel	Dyed black
2	Case	Carbon steel	Black zinc chromated
3	Ring	Chromium molybdenum steel	
4	Cap	Carbon steel	Black zinc chromated
5	Dust cover	Synthetic rubber	
6	Set screw	Carbon steel	Zinc chromated
7	Rod end nut	Carbon steel	Zinc chromated
8	Flange	Rolled steel	Black zinc chromated
9	Foot	Rolled steel	Black zinc chromated

Accessory Dimensions

Rod end nut

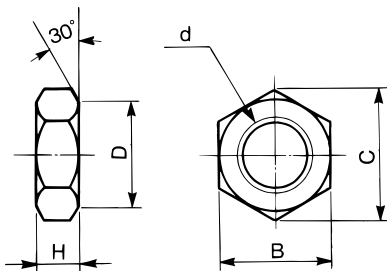

d: Thread nominal size	H	B	C	D
M3 x 0.5	2.4	5.5	6.4	5.3
M4 x 0.7	3.2	7	8.1	6.8
M5 x 0.8	4	8	9.2	7.8
M6 x 1	5	10	11.5	9.8
M8 x 1	5	13	15	12.5
M8 x 1.25	5	13	15	12.5
M10 x 1	6	17	19.6	16.5
M10 x 1.25	6	17	19.6	16.5
M10 x 1.5	6	17	19.6	16.5
M12 x 1.25	7	19	21.9	18
M12 x 1.5	7	19	21.9	18
M12 x 1.75	7	19	21.9	18
M14 x 1.5	8	22	25.4	21
M16 x 1.5	10	24	27.7	23
M16 x 2	10	24	27.7	23
M18 x 1.5	11	27	31.2	26

d: Thread nominal size	H	B	C	D
M20 x 1.5	12	30	34.6	29
M20 x 2.5	12	30	34.6	29
M22 x 1.5	13	32	37	31
M24 x 1.5	14	36	41.6	34
M24 x 2	14	36	41.6	34
M24 x 3	14	36	41.6	34
M26 x 1.5	16	41	47.3	39
M27 x 1.5	16	41	47.3	39
M27 x 2	16	41	47.3	39
M30 x 1.5	18	46	53.1	44
M30 x 2	18	46	53.1	44
M33 x 2	20	50	57.7	48
M36 x 1.5	21	55	63.5	53
M39 x 1.5	23	60	69.3	57
M42 x 3	25	65	75	62
M48 x 1.5	29	75	86.5	72

Floating Joint Replacement Parts

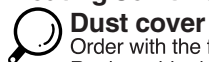

Dust cover

Order with the following part no. if dust cover is damaged.

Replaceable dust cover is only for the basic style. Flange style and foot style cannot be replaced.

Part no. for dust cover	Applicable model
P2152051	JA6, JA10
P2152052	JA15, JB12, JB16
P215215	JA20, JB20
P215225	JA30, JB30
P215235	JA40, JB40
P215245	JA63, JA50, JB63

Part no. for dust cover	Applicable model
P215255	JA80, JAH40, JB80
P215265	JA100, JAH50, JB100
P215275	JA125, JAH63
P215285	JA140, JAH80, JB140
P215295	JA160, JAH100, JB160

Rod end nut

Rod end nut (1 pc.) is attached to the standard type of Series JA and JAH.

But if it is needed additionally, order it as follows.

Example.....Rod end nut for JA40-14-150

Series JA

Basic Style: JA6 to JA160

JA6 to 15

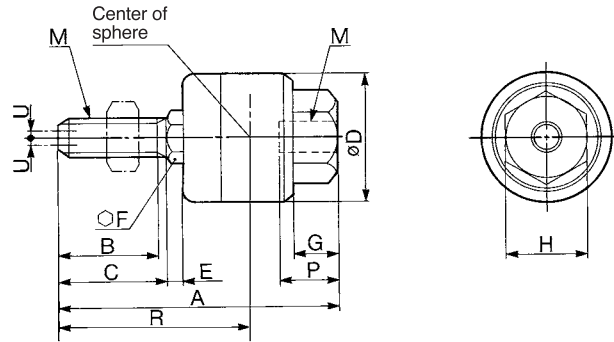

Use the precision spanner for clock 4 mm in the case of mounting male thread of JA6 and JA10.

JA20 to 160

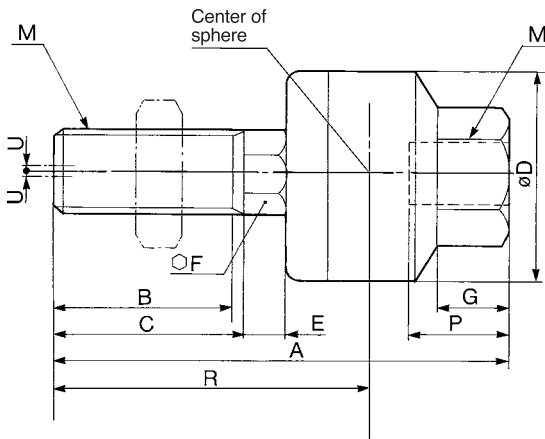

Without C-dimension

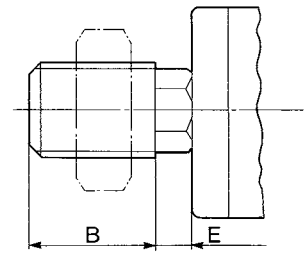

Applicable bore size (mm)	Model	M		A	B	C	D	E	F	G	H	Center of sphere R	Maximum thread depth P	Allowable eccentricity U	Maximum operating tension and compression force (N)	Mass (kg)
		Nominal size	Pitch													
6	JA6-3-050	3	0.5	23.2	7	8	12	1.5	4	3.2	5.5	15	5	0.5	19	0.01
10 (CJ1)	JA10-4-070	4	0.7	26	9	10	12	1.5	4	4	7	17	5.5	0.5	54	0.01
10 (CZ1), 15 (CJ1)	JA15-5-080	5	0.8	34.5	12.5	14	16	2	6	5	10	23	7	0.5	123	0.02
15 (CZ1)	JA15-6-100	6	1	34.5	12.5	14	16	2	6	5	10	23	7	0.5	123	0.02
20	JA20-8-125	8	1.25	44	17.5	-	21	4.5	7	7	13	30.5	8	0.5	1100	0.05
25, 32	JA30-10-125	10	1.25	49.5	19.5	-	24	5	8	8	17	34	9	0.5	2500	0.07
40	JA40-14-150	14	1.5	60	20	-	31	6	11	11	22	38	13	0.75	4400	0.16
50, 63	JA63-18-150	18	1.5	74.5	25	-	41	7.5	14	13.5	27	47.5	15	1	11000	0.31
80	JA80-22-150	22	1.5	89.5	29	-	50	9.5	19	16	32	56.5	18	1.25	18000	0.58
100	JA100-26-150	26	1.5	110	35	-	59.5	11.5	24	20	41	68	24	2	28000	1.08
125, 140	JA140-30-150	30	1.5	152	42	45	79	14	30	22	46	94.5	38	2.5	54000	2.7
160	JA160-36-150	36	1.5	178	52	55	96	16	36	24	55	112	42	3	71000	4.7

Option Pneumatic: Up to 1 MPa Hydraulic: Up to 3.5 MPa

20	JA20-8-100	8	1	44	17.5	-	21	4.5	7	7	13	30.5	8	0.5	1100	0.05
25	JA25-10-150	10	1.5	49.5	19.5	-	24	5	8	8	17	34	9	0.5	2500	0.07
32	JA32-10-100	10	1	49.5	19.5	-	24	5	8	8	17	34	9	0.5	2500*	0.07
32, 40	JA40-12-125	12	1.25	60	20	-	31	6	11	11	22	38	13	0.75	4400	0.16
40	JA40-12-150	12	1.5	60	20	-	31	6	11	11	22	38	13	0.75	4400	0.16
32, 40	JA40-12-175	12	1.75	60	20	-	31	6	11	11	22	38	13	0.75	4400	0.16
50	JA50-16-150	16	1.5	71.5	22	-	41	7.5	14	13.5	27	44.5	15	1	11000	0.3
50, 63	JA63-16-200	16	2	71.5	22	-	41	7.5	14	13.5	27	44.5	15	1	11000	0.3
80	JA80-20-250	20	2.5	90.5	27	30	50	9.5	19	16	32	57.5	18	1.25	18000	0.6
100	JA100-24-300	24	3	110	32	35	59.5	11.5	24	20	41	68	24	2	28000	1.05
100	JA100-27-150	27	1.5	110	35	-	59.5	11.5	24	20	41	68	24	2	28000	1.08
125	JA125-27-200	27	2	123	34	38	66	13	24	20	41	77	24	2	28000*	1.5
160	JA160-33-200	33	2	165	38	42	96	16	36	24	55	99	42	3	71000	4.5

* For 3.5 MPa hydraulic cylinders, operate within the maximum tension and compression force.

Flange Style: JAF20 to JAF160

JAF20 to $\phi 40$

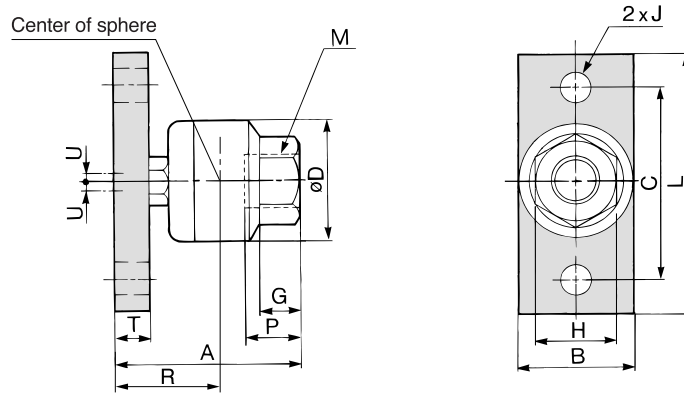

ϕ JAF50 to ϕ 160

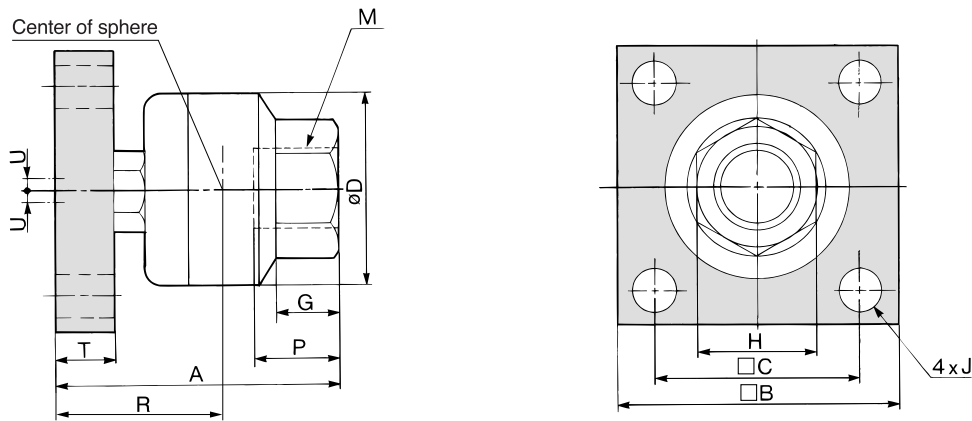

Applicable bore size (mm)	Model	M		A	B	L	C	D	T	J	G	H	Center of sphere R	Maximum thread depth P	Allowable eccentricity U	Maximum operating tension and compression force (N)	Mass (kg)
		Nominal size	Pitch														
Standard Pneumatic: Up to 1 MPa Hydraulic: Up to 3.5 MPa																	
20	JAF20-8-125	8	1.25	32.5	19	48	36	21	6	6.6	7	13	19	8	0.5	1100	0.08
25, 32	JAF30-10-125	10	1.25	36	25	52	40	24	6	6.6	8	17	20.5	9	0.5	2500	0.12
40	JAF40-14-150	14	1.5	49	32	70	52	31	9	9	11	22	27	13	0.75	4400	0.28
50, 63	JAF63-18-150	18	1.5	61.5	65	-	45	41	12	9	13.5	27	34.5	15	1	11000	0.63
80	JAF80-22-150	22	1.5	76.5	75	-	55	50	16	11	16	32	43.5	18	1.25	18000	1.15
100	JAF100-26-150	26	1.5	94	90	-	65	59.5	19	11	20	41	52	24	2	28000	2.07
125, 140	JAF140-30-150	30	1.5	131	125	-	82	79	24	18	22	46	73.5	38	2.5	36000*	5.2
160	JAF160-36-150	36	1.5	152	150	-	100	96	29	22	24	55	86	42	3	55000*	9

Option Pneumatic: Up to 1 MPa Hydraulic: Up to 3.5 MPa																	
20	JAF20-8-100	8	1	32.5	19	48	36	21	6	6.6	7	13	19	8	0.5	1100	0.08
25	JAF25-10-150	10	1.5	36	25	52	40	24	6	6.6	8	17	20.5	9	0.5	2500	0.12
32	JAF32-10-100	10	1	36	25	52	40	24	6	6.6	8	17	20.5	9	0.5	2500*	0.12
32, 40	JAF40-12-125	12	1.25	49	32	70	52	31	9	9	11	22	27	13	0.75	4400	0.28
40	JAF40-12-150	12	1.5	49	32	70	52	31	9	9	11	22	27	13	0.75	4400	0.28
32, 40	JAF40-12-175	12	1.75	49	32	70	52	31	9	9	11	22	27	13	0.75	4400	0.28
50	JAF50-16-150	16	1.5	61.5	65	-	45	41	12	9	13.5	27	34.5	15	1	11000	0.63
50, 63	JAF63-16-200	16	2	61.5	65	-	45	41	12	9	13.5	27	34.5	15	1	11000	0.63
80	JAF80-20-250	20	2.5	76.5	75	-	55	50	16	11	16	32	43.5	18	1.25	18000	1.15
100	JAF100-24-300	24	3	94	90	-	65	59.5	19	11	20	41	52	24	2	28000	2.07
100	JAF100-27-150	27	1.5	94	90	-	65	59.5	19	11	20	41	52	24	2	28000	2.07
125	JAF125-27-200	27	2	106	100	-	72	66	21	18	20	41	60	24	2	28000*	2.8
160	JAF160-33-200	33	2	152	150	-	100	96	29	22	24	55	86	42	3	55000*	9

* For 3.5 MPa hydraulic cylinders, operate within the maximum tension and compression force.

J□

D-□

-X□

Individual
-X□
Technical
data

Series JA

Foot Style: JAL20 to JAF160

JAL20 to 100

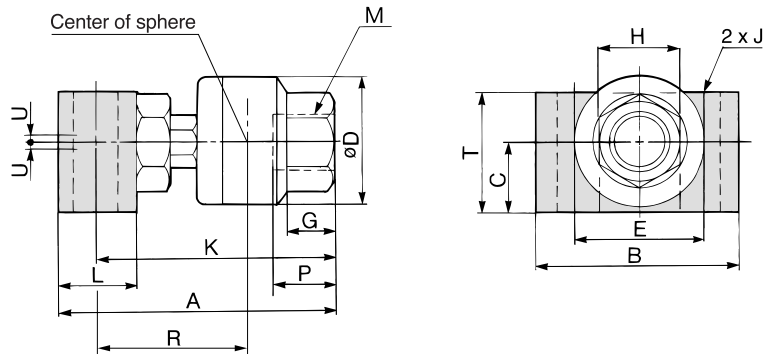

JAL125 to 160

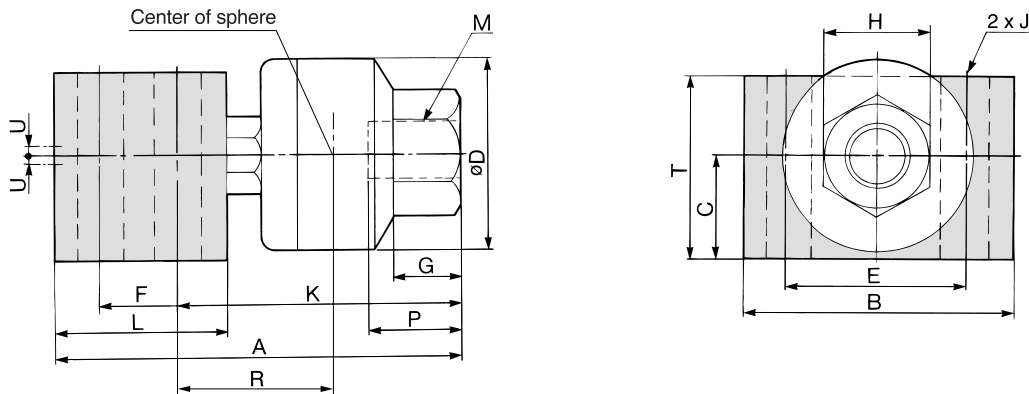

Applicable bore size (mm)	Model	M		A	B	C	D	E	F	K	L	T	J	G	H	Center of sphere R	Maximum thread depth P	Allowable eccentricity U	Maximum operating tension and compression force (N)	Mass (kg)
		Nominal size	Pitch																	
20	JAL20-8-125	8	1.25	44	30	11.5	21	18	-	38	12	19	6.6	7	13	24.5	8	0.5	1000*	0.09
25, 32	JAL30-10-125	10	1.25	52	42	14	24	24	-	44	16	25	9	8	17	28.5	9	0.5	2000*	0.18
40	JAL40-14-150	14	1.5	67	52	17.5	31	30	-	57.5	19	30	11	11	22	35.5	13	0.75	4400	0.36
50, 63	JAL63-18-150	18	1.5	82.5	56	23	41	34	-	71.5	22	38	11	13.5	27	44.5	15	1	9000*	0.61
80	JAL80-22-150	22	1.5	98.5	70	28	50	42	-	86	25	47	14	16	32	53	18	1.25	14000*	1.09
100	JAL100-26-150	26	1.5	123	80	35	59.5	48	-	107	32	58	16	20	41	65	24	2	22000*	2.03
125, 140	JAL140-30-150	30	1.5	187	96	45	79	60	44	125	80	79	18	22	46	67.5	38	2.5	36000*	6.4
160	JAL160-36-150	36	1.5	213	116	55	96	74	48	144	90	89	22	24	55	78	42	3	55000*	10

Option Pneumatic: Up to 1 MPa Hydraulic: Up to 3.5 MPa

20	JAL20-8-100	8	1	44	30	11.5	21	18	-	38	12	19	6.6	7	13	24.5	8	0.5	1000*	0.09
25	JAL25-10-150	10	1.5	52	42	14	24	24	-	44	16	25	9	8	17	28.5	9	0.5	2000	0.18
32	JAL32-10-100	10	1	52	42	14	24	24	-	44	16	25	9	8	17	28.5	9	0.5	2000*	0.18
32, 40	JAL40-12-125	12	1.25	67	52	17.5	31	30	-	57.5	19	30	11	11	22	35.5	13	0.75	4400	0.36
40	JAL40-12-150	12	1.5	67	52	17.5	31	30	-	57.5	19	30	11	11	22	35.5	13	0.75	4400	0.36
32, 40	JAL40-12-175	12	1.75	67	52	17.5	31	30	-	57.5	19	30	11	11	22	35.5	13	0.75	4400	0.36
50	JAL50-16-150	16	1.5	82.5	56	23	41	34	-	71.5	22	38	11	13.5	27	44.5	15	1	9000	0.61
50, 63	JAL63-16-200	16	2	82.5	56	23	41	34	-	71.5	22	38	11	13.5	27	44.5	15	1	9000*	0.61
80	JAL80-20-250	20	2.5	98.5	70	28	50	42	-	86	25	47	14	16	32	53	18	1.25	14000*	1.09
100	JAL100-24-300	24	3	123	80	35	59.5	48	-	107	32	58	16	20	41	65	24	2	22000*	2.03
100	JAL100-27-150	27	1.5	123	80	35	59.5	48	-	107	32	58	16	20	41	65	24	2	22000*	2.03
125	JAL125-27-200	27	2	155	88	38	66	54	36	102	70	69	14	20	41	56	24	2	28000*	4.1
160	JAL160-33-200	33	2	213	116	55	96	74	48	144	90	89	22	24	55	78	42	3	55000*	10

* For 3.5 MPa hydraulic cylinders, operate within the maximum tension and compression force.

Floating Joint: Heavy Load Type

Series JAH

Specifications

Operating pressure	Hydraulic cylinder: 7 MPa or less
Mounting	Basic style, Flange style, Foot style

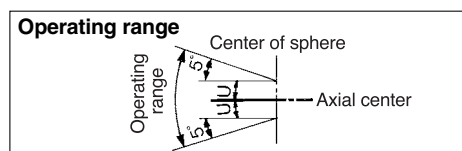

Series JAH



Series JAHL
(Foot style)

Series JAHF
(Flange style)

Specifications

Model	Applicable bore size (mm)	Applicable cylinder nominal thread size	Maximum operating tension and compression force (N)			Allowable eccentricity U (mm)	Rotating angle
			Basic style	Flange style	Foot style		
Standard/Thread nominal size							
JAH□40-16-150	40	M16 x 1.5	11000	9000	9000	1.25	±5°
JAH□50-20-150	50	M20 x 1.5	18000	14000	14000	2	
JAH□63-24-150	63	M24 x 1.5	28000	22000	22000	2	
JAH□80-30-150	80	M30 x 1.5	54000	36000	36000	2.5	
JAH□100-39-150	100	M39 x 1.5	71000	55000	55000	3	
JAH□100-48-150	100	M48 x 1.5	71000	55000	55000	3	
Option/Thread nominal size							
JAH□63-24-200	63	M24 x 2	28000	22000	22000	2	±5°
JAH□80-30-200	80	M30 x 2	54000	36000	36000	2.5	
JAH□100-42-300	100	M42 x 3	71000	55000	55000	3	

How to Order

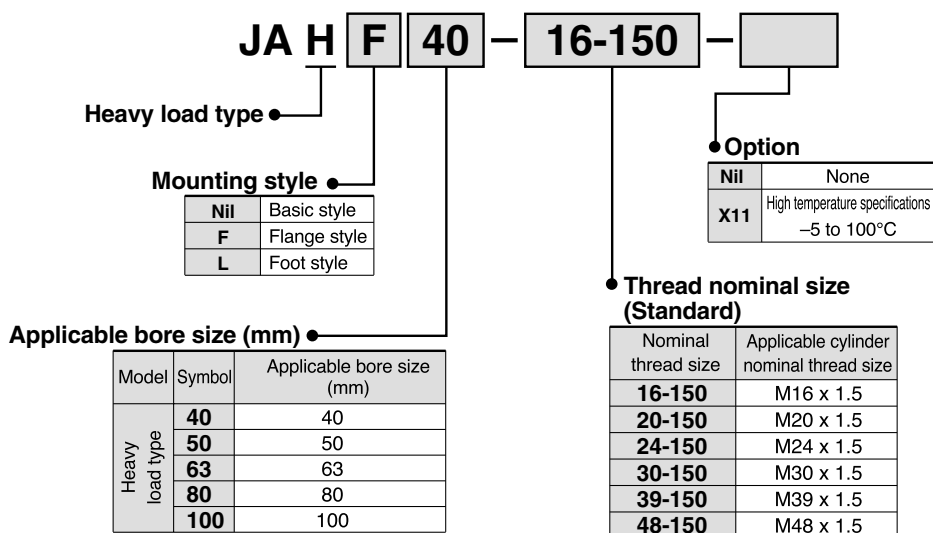

⚠ Precautions

Be sure to read before handling.
Refer to front matters 54 and 55 for Safety Instructions.

Mounting

⚠ Warning

- To screw the male threads of the rod into the female threads of the socket or the case, make sure that it does not bottom out. If the floating joint is used with its rod bottomed out, the stud will not be able to float, causing damage. For the screw-in depth of the female threads, refer to the dimensions (page 914). As a rule, after the rod bottoms out, back off 1 to 2 turns. The dust cover may be fixed with the stud, so loosen them before using.

- When screwing stud or socket, or case in the driven object, make sure to screw them in the state that dust cover has been removed from the case. If screwing without removing dust cover, dust cover might be broken.
- To use a floating joint to connect the cylinder rod to a driven body, secure it in place by applying a torque that is appropriate for the thread size. Also, if there is a risk of loosening during operation, take measures to prevent loosening, such as using a locking pin or thread adhesive. In the event that the connected portion becomes loose, the driven body might lose control or fall off, leading to equipment damage or injury to personnel.
- Do not use for rotational applications, because it is not a fitting designed for rotational axis.

Maintenance

⚠ Warning

- Do not reuse if disassembled. High strength adhesive is applied to the portion of the connection that is threaded to prevent it from loosening, and it must not be disassembled. If it is forcefully disassembled, it could lead to damage.

Series JAH

Construction

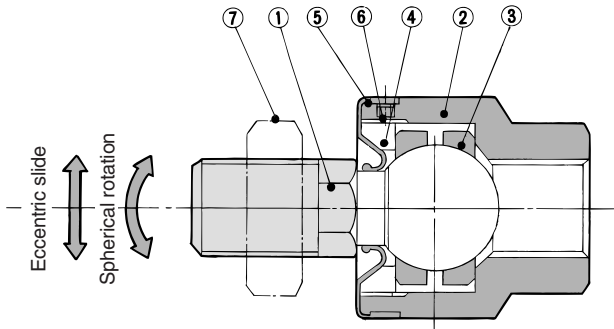

Component Parts

No.	Description	Material	Note
1	Stud	Chromium molybdenum steel	Dyed black
2	Case	Carbon steel	Black zinc chromated
3	Ring	Chromium molybdenum steel	
4	Cap	Carbon steel	Black zinc chromated
5	Dust cover	Synthetic rubber	
6	Set screw	Carbon steel	Zinc chromated
7	Rod end nut	Carbon steel	Zinc chromated
8	Flange	Rolled steel plate	Black zinc chromated
9	Foot	Rolled steel plate	Black zinc chromated

Basic Style: JAH

JAH40 to 100

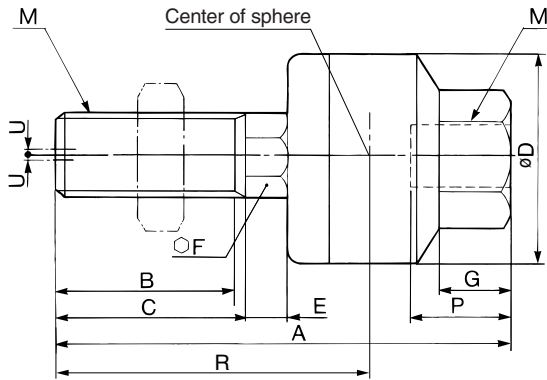

Without C-dimension

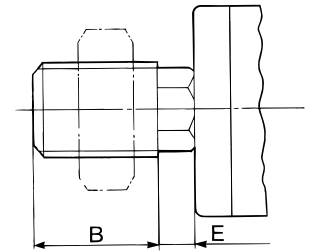

(mm)

Applicable bore size (mm)	Model	M		A	B	C	D	E	F	G	H	Center of sphere R	Maximum thread depth P	Allowable eccentricity U	Maximum operating tension and compression force (N)	Mass (kg)
		Nominal size	Pitch													

Standard: Heavy Load Type Hydraulic: Up to 7 MPa

40	JAH40-16-150	16	1.5	85.5	22	25	50	9.5	19	16	32	52.5	18	1.25	11000	0.58
50	JAH50-20-150	20	1.5	101	28	31	59.5	11.5	24	16	32	64	18	2	18000	1.08
63	JAH63-24-150	24	1.5	120	32	35	66	13	27	20	41	74	24	2	28000	1.5
80	JAH80-30-150	30	1.5	152	42	45	79	14	30	22	46	94.5	38	2.5	54000	2.7
100	JAH100-39-150	39	1.5	178	52	55	96	16	36	24	55	112	42	3	71000	4.8
100	JAH100-48-150	48	1.5	191	61	-	96	16	36	28	70	118	49	3	71000	5.4

Option: Heavy Load Type Hydraulic: Up to 7 MPa

63	JAH63-24-200	24	2	120	32	35	66	13	27	20	41	74	24	2	28000	1.5
80	JAH80-30-200	30	2	152	41	45	79	14	30	22	46	94.5	38	2.5	54000	2.7
100	JAH100-42-300	42	3	178	55	-	96	16	36	24	55	112	42	3	71000	4.8

Flange Style: JAFH

JAFH40 to 100

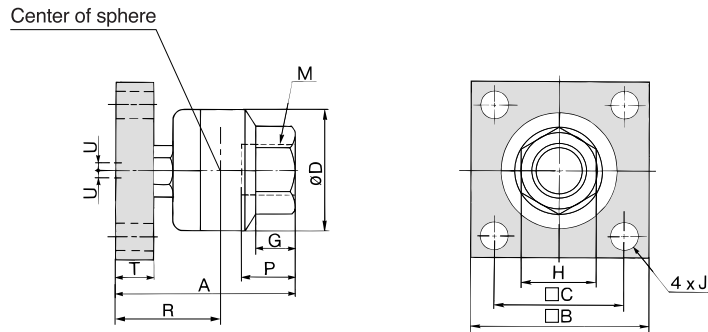

Applicable bore size (mm)	Model	M		A	B	C	D	T	J	G	H	Center of sphere R	Maximum thread depth P	Allowable eccentricity U	Maximum operating tension and compression force (N)	Mass (kg)
		Nominal size	Pitch													

Standard: Heavy Load Type Hydraulic: Up to 7 MPa

40	JAHF40-16-150	16	1.5	76	75	50	50	15	11	16	32	43	18	1.25	9000	1.25
50	JAHF50-20-150	20	1.5	89	100	62	59.5	18	14	16	32	52	18	2	14000	2.5
63	JAHF63-24-150	24	1.5	106	100	72	66	21	18	20	41	60	24	2	22000	2.8
80	JAHF80-30-150	30	1.5	131	125	82	79	24	18	22	46	73.5	38	2.5	36000	5.2
100	JAHF100-39-150	39	1.5	152	150	100	96	29	22	24	55	86	42	3	55000	9
100	JAHF100-48-150	48	1.5	159	150	100	96	29	22	28	70	86	49	3	55000	9.3

Option: Heavy Load Type Hydraulic: Up to 7 MPa

63	JAHF63-24-200	24	2	106	100	72	66	21	18	20	41	60	24	2	22000	2.8
80	JAHF80-30-200	30	2	131	125	82	79	24	18	22	46	73.5	38	2.5	36000	5.2
100	JAHF100-42-300	42	3	152	150	100	96	29	22	24	55	86	42	3	55000	9

Foot Style: JAHL

JAHL40, 50

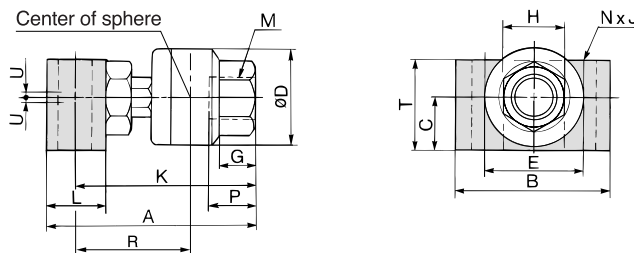

JAHL63 to 100

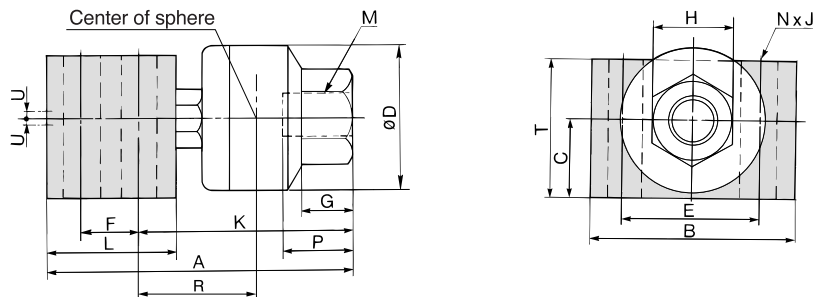

Applicable bore size (mm)	Model	M		A	B	C	D	E	F	K	L	T	N	J	G	H	Center of sphere R	Maximum thread depth P	Allowable eccentricity U	Maximum operating tension and compression force (N)	Mass (kg)
		Nominal size	Pitch																		

Standard: Heavy Load Type Hydraulic: Up to 7 MPa

40	JAHL40-16-150	16	1.5	98.5	70	28	50	42	-	86	25	47	2	14	16	32	53	18	1.25	9000	1.09
50	JAHL50-20-150	20	1.5	123	80	35	59.5	48	-	107	32	58	2	16	20	41	65	24	2	14000	2.03
63	JAHL63-24-150	24	1.5	155	88	38	66	54	36	102	70	69	4	18	20	41	56	24	2	22000	4.1
80	JAHL80-30-150	30	1.5	187	96	45	79	60	44	125	80	79	4	18	22	46	67.5	38	2.5	36000	6.4
100	JAHL100-39-150	39	1.5	213	116	55	96	74	48	144	90	89	4	22	24	55	78	42	3	55000	10
100	JAHL100-48-150	48	1.5	220	116	55	96	74	48	151	90	89	4	22	28	70	78	49	3	55000	10.5

Option: Heavy Load Type Hydraulic: Up to 7 MPa

63	JAHL63-24-200	24	2	155	88	38	66	54	36	102	70	69	4	18	20	41	56	24	2	22000	4.1
80	JAHL80-30-200	30	2	187	96	45	79	60	44	125	80	79	4	18	22	46	67.5	38	2.5	36000	6.4
100	JAHL100-42-300	42	3	213	116	55	96	74	48	144	90	89	4	22	24	55	78	42	3	55000	10

Floating Joint: For Compact Cylinders

Series JB

Specifications

Operating pressure	Air pressure compact cylinder 1 MPa or less
---------------------------	--

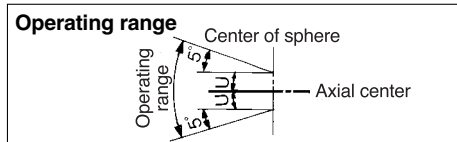

Specifications

Model	Applicable bore size (mm)	Applicable cylinder nominal thread size	Maximum operating tension and compression force (N)		Allowable eccentricity U (mm)	Rotating angle
			Compression side	Tension side		
JB12-3-050	12	M3 x 0.5	112	112	0.5	±5°
JB16-4-070	16	M4 x 0.7	200	200	0.5	
JB20-5-080	20	M5 x 0.8	1100	300	0.5	
JB25-6-100	25	M6 x 1	2500	500	0.5	
JB40-8-125	32, 40	M8 x 1.25	6000	1300	0.75	
JB63-10-150	50, 63	M10 x 1.5	11000	3100	1	
JB80-16-200	80	M16 x 2	18000	5000	1.25	
JB100-20-250	100	M20 x 2.5	28000	7900	2	
JB140-22-250	125, 140	M22 x 2.5	54000	15300	2.5	
JB160-24-300	160	M24 x 3	71000	20000	3	

How to Order

J B 40 - 8-125 - [Option]

For compact cylinders/
Female thread

Applicable bore size (mm)

Symbol	Applicable bore size (mm)
12	12
16	16
20	20
25	25
40	32, 40
63	50, 63
80	80
100	100
140	125, 140
160	160

Thread nominal size

Nominal thread size	Applicable cylinder nominal thread size
3-050	M3 x 0.5
4-070	M4 x 0.7
5-080	M5 x 0.8
6-100	M6 x 1
8-125	M8 x 1.25
10-150	M10 x 1.5
16-200	M16 x 2
20-250	M20 x 2.5
22-250	M22 x 2.5
24-300	M24 x 3

Option

Nil	None
X11	High temperature specifications -5 to 100°C

⚠ Precautions

Be sure to read before handling.
Refer to front matters 54 and 55 for Safety Instructions.

Mounting

⚠ Warning

- To screw the male threads of the rod into the female threads of the socket or the case, make sure that it does not bottom out. If the floating joint is used with its rod bottomed out, the stud will not be able to float, causing damage. For the screw-in depth of the female threads, refer to the dimensions (page 917). As a rule, after the rod bottoms out, back off 1 to 2 turns.
The dust cover may be fixed with the stud, so loosen them before using.

- When screwing stud or socket, or case in the driven object, make sure to screw them in the state that dust cover has been removed from the case. If screwing without removing dust cover, dust cover might be broken.
- To use a floating joint to connect the cylinder rod to a driven body, secure it in place by applying a torque that is appropriate for the thread size. Also, if there is a risk of loosening during operation, take measures to prevent loosening, such as using a locking pin or thread adhesive. In the event that the connected portion becomes loose, the driven body might lose control or fall off, leading to equipment damage or injury to personnel.
- Do not use for rotational applications, because it is not a fitting designed for rotational axis.

Maintenance

⚠ Warning

- Do not reuse if disassembled.
High strength adhesive is applied to the portion of the connection that is threaded to prevent it from loosening, and it must not be disassembled. If it is forcefully disassembled, it could lead to damage.

Construction

∅12, ∅16

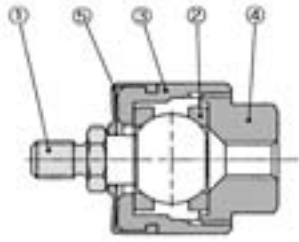

∅20 to ∅160

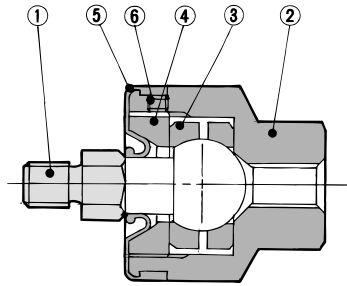

Component Parts

No.	Description	Material	Note
1	Stud	Free-cutting steel	Electroless nickel plated
2	Case	Brass	Electroless nickel plated
3	Ring	Stainless steel	
4	Socket	Brass	Electroless nickel plated
5	Dust cover	Synthetic rubber	

No.	Description	Material	Note
1	Stud	Chromium molybdenum steel	Dyed black
2	Case	Carbon steel	Black zinc chromated
3	Ring	Chromium molybdenum steel	
4	Cap	Carbon steel	Black zinc chromated
5	Dust cover	Synthetic rubber	
6	Set screw	Carbon steel	Zinc chromated

Basic Style: JB

JB20, 16

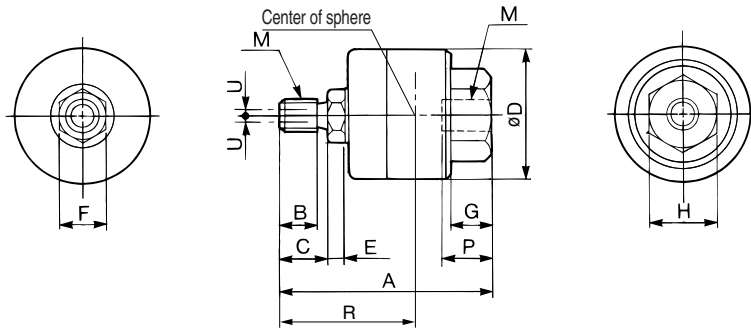

JB20 to 160

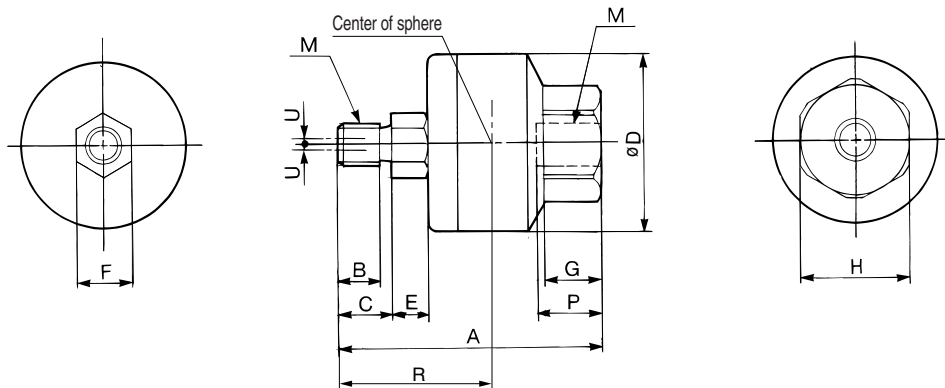

Applicable bore size (mm)	Model	M		A	B	C	D	E	F	G	H	Center of sphere R	Maximum thread depth P	Allowable eccentricity U	Maximum operating tension and compression force (N)		Mass (kg)
		Nominal size	Pitch												Compression	Tension	
12	JB12-3-050	3	0.5	24.5	3	4	16	2	6	5	10	13	7	0.5	112	112	0.02
16	JB16-4-070	4	0.7	26.5	4.5	6	16	2	6	5	10	15	7	0.5	200	200	0.02
20	JB20-5-080	5	0.8	33	5	6.5	21	4.5	7	7	13	19.5	8	0.5	1100	300	0.04
25	JB25-6-100	6	1	38	6	8	24	5	8	8	17	22.5	9	0.5	2500	500	0.07
32, 40	JB40-8-125	8	1.25	51	8.5	11	31	6	11	11	22	29	13	0.75	6000	1300	0.15
50, 63	JB63-10-150	10	1.5	62.5	10	13	41	7.5	14	13.5	27	35.5	15	1	11000	3100	0.29
80	JB80-16-200	16	2	80.5	16	20	50	9.5	19	16	32	47.5	18	1.25	18000	5000	0.56
100	JB100-20-250	20	2.5	101	21	26	59.5	11.5	24	20	41	59	24	2	28000	7900	1.04
125, 140	JB140-22-250	22	2.5	129	17	22	79	14	30	22	46	71.5	38	2.5	54000	15300	2.6
160	JB160-24-300	24	3	149	20	26	96	16	36	24	55	83	42	3	71000	20000	4.5

J□

D-□

-X□

Individual -X□

Technical data

Floating Joint: Stainless Steel Type

Series JS

Specifications

Operating pressure	Pneumatic cylinder: 1 MPa or less
	Hydraulic cylinder: 3.5 MPa or less
Mounting	Basic style

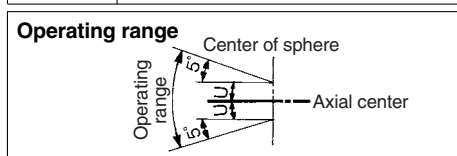

⚠ Precautions

- Be sure to read before handling.
- Refer to front matters 54 and 55 for Safety Instructions.

Mounting

⚠ Warning

- For the screw-in depth of the female threads, refer to the dimensions (page 920).
- When screwing stud or socket, or case in the driven object, make sure to screw them in the state that dust cover has been removed from the case. If screwing without removing dust cover, dust cover might be broken.
- To use a floating joint to connect the cylinder rod to a driven body, secure it in place by applying a torque that is appropriate for the thread size. Also, if there is a risk of loosening during operation, take measures to prevent loosening, such as using a locking pin or thread adhesive. In the event that the connected portion becomes loose, the driven body might lose control or fall off, leading to equipment damage or injury to personnel.
- Do not use for rotational applications, because it is not a fitting designed for rotational axis.

Maintenance

⚠ Warning

- Do not reuse if disassembled. High strength adhesive is applied to the portion of the connection that is threaded to prevent it from loosening, and it must not be disassembled. If it is forcefully disassembled, it could lead to damage.

Specifications

Model	Applicable bore size (mm) ⁽¹⁾	Applicable cylinder nominal thread size	Maximum operating tension and compression force (N)	Allowable eccentricity U (mm)	Operating pressure		Ambient temperature
					Air pressure cylinder	Hydraulic cylinder	
JS10-4-070	10	M4 x 0.7	80	0.5	1 MPa or less	3.5 MPa ⁽²⁾ or less	-5 to 70°C
JS16-5-080	10, 16	M5 x 0.8	210	0.5			
JS20-8-125	20	M8 x 1.25	1100	0.5			
JS32-10-125	25, 32	M10 x 1.25	2500	0.5			
JS40-14-150	40	M14 x 1.5	6000	0.75			
JS63-18-150	50, 63	M18 x 1.5	11000	1			

Note 1) Think of applicable bore size as a guide. For details, confirm the rod end thread diameter of a cylinder to be used in the catalog.

Note 2) For 3.5 MPa hydraulic cylinders, operate within the maximum tension and compression force.

How to Order

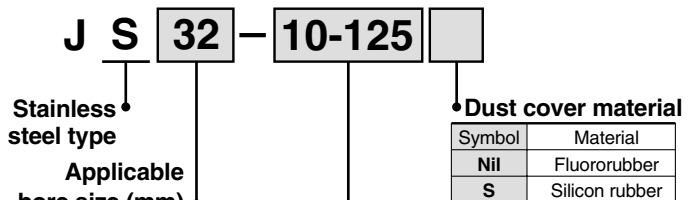

Symbol	Applicable bore size (mm)
10	10
16	10, 16
20	20
32	25, 32
40	40
63	50, 63

Symbol	Applicable cylinder nominal thread size
4-070	M4 x 0.7
5-080	M5 x 0.8
8-125	M8 x 1.25
10-125	M10 x 1.25
14-150	M14 x 1.5
18-150	M18 x 1.5

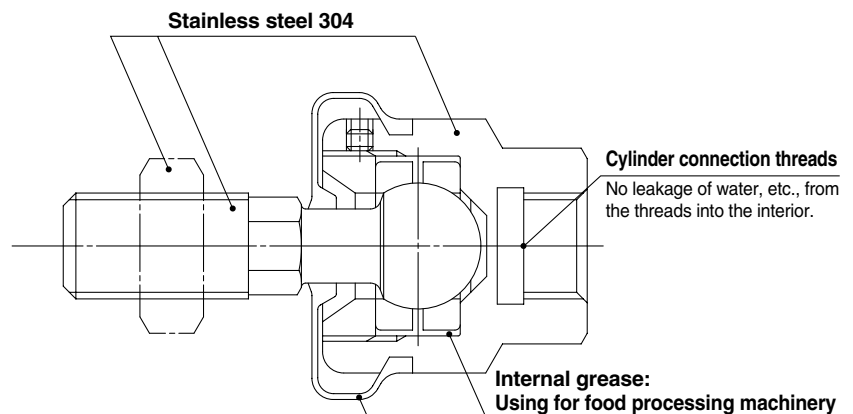

- Dust cover (fluororubber, silicon rubber)**
- The shape of the cover prevents residual liquid.
 - Improved sealing

Construction

ø10, ø16

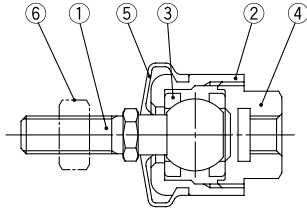

ø20 to ø63

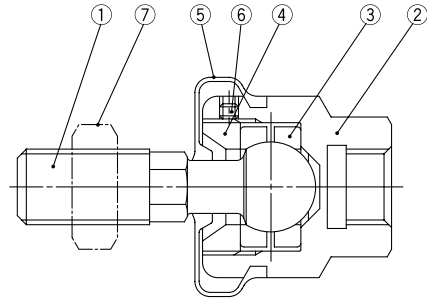

Component Parts

No.	Description	Material	Note
1	Stud	Stainless steel	
2	Case	Stainless steel	
3	Ring	Stainless steel	
4	Socket	Stainless steel	
5	Dust cover	Fluororubber/Silicon rubber	
6	Rod end nut	Stainless steel	

Component Parts

No.	Description	Material	Note
1	Stud	Stainless steel (Thread parts)	Electroless nickel plated
2	Case	Stainless steel	
3	Ring	Chromium molybdenum steel	Electroless nickel plated
4	Cap	Carbon steel	Electroless nickel plated
5	Dust cover	Fluororubber/Silicon rubber	
6	Set screw	Carbon steel	
7	Rod end nut	Stainless steel	

Replacement Parts

Dust cover

When the dust cover is damaged and deteriorated, order with the part number as shown below.

Model	Part no. for dust cover	
	Fluoro rubber	Silicon rubber
JS10	P21530511	P21530512
JS16	P21530521	P21530522
JS20	P2153151	P2153152
JS32	P2153251	P2153252
JS40	P2153351	P2153352
JS63	P2153451	P2153452

Rod end nut

Rod end nut (1 pc.) is attached to the standard type of Series JS.
But if it is needed additionally, order it as follows. For details, refer to page 920.
Example.....Nut for JS40

J□

D-□

-X□

Individual
-X□

Technical
data

Series JS

Dimensions

JS10, 16

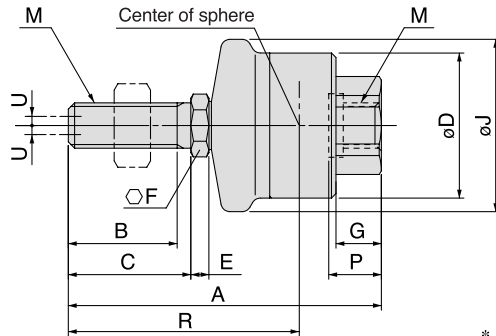

* Use the precision spanner for clock 4 mm in the case of mounting male thread of JS10.

JS20, 32, 40, 63

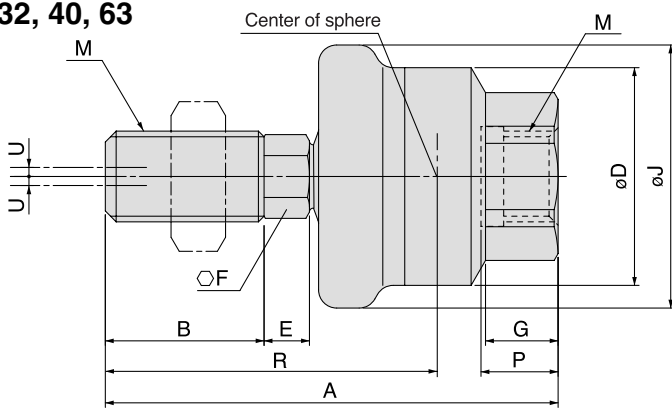

Model	M	A	B	C	D	E	F	G	H	J	Center of sphere R	Max. thread depth P	Allowable eccentricity U	Max. operating tension and compression force (N)
JS10-4-070	M4 x 0.7	26	8.5	9.5	12	1.5	4	4	7	14.4	17	4.7	0.5	80
JS16-5-080	M5 x 0.8	34.5	12	13.5	16	2	6	5	10	19	23	5.8	0.5	210
JS20-8-125	M8 x 1.25	43.9	15.5	—	21	4.5	7	7	13	24.8	29.9	7.3	0.5	1100
JS32-10-125	M10 x 1.25	49.5	17.5	—	24	5	8	8	17	29	33.5	8.5	0.5	2500
JS40-14-150	M14 x 1.5	60	18.5	—	31	5	11	11	22	38.4	38	11.6	0.75	6000
JS63-18-150	M18 x 1.5	74.5	23	—	41	7	14	13.5	27	49.2	47.5	14.3	1	11000

Rod end nut

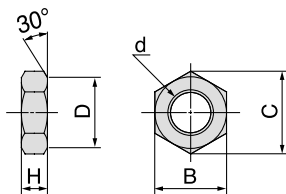

Description	d: Thread nominal size	H	B	C	D
JS10 nut	M4 x 0.7	3.2	7	8.1	6.8
JS16 nut	M5 x 0.8	4	8	9.2	7.8
JS20 nut	M8 x 1.25	5	13	15	12.5
JS32 nut	M10 x 1.25	6	17	19.6	16.5
JS40 nut	M14 x 1.5	8	22	25.4	21
JS63 nut	M18 x 1.5	11	27	31.2	26