

Flow Switch

Paddle Style Flow Switch

Series IF3



For details about certified products conforming to international standards, visit us at www.smcworld.com.

Flow switches, series IF3 detect and confirm liquid flow, generally used in fields such as air conditioning, water supply equipment, etc.

- Piping sizes ranges from 3/4B to 6B.
- Wide range of applicable fluids.
Wetted metal part materials: Copper alloy, Stainless steel
- Various enclosures (No water protected).
Open type, Dripproof/Rainproof, Splashproof /Low jetproof type



How to Order

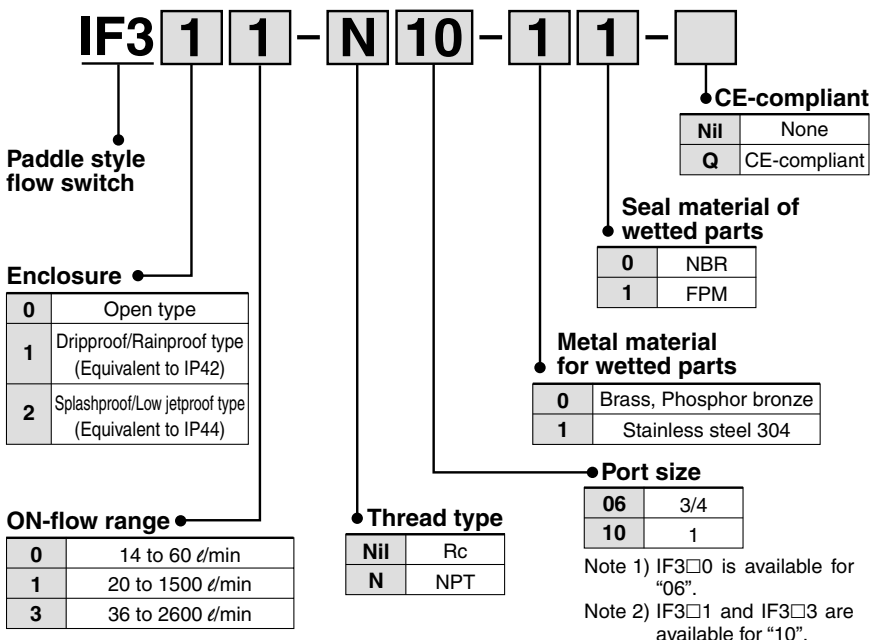

Specifications

Fluid	Copper alloy	Water/Non corrosive liquid
	Stainless steel 304	Liquid, which does not corrode stainless steel 304.
Max. pressure	1 MPa	
Water resistance	1.75 MPa	
Insulation resistance	100 M Ω (500 DC by megameter)	
Withstand voltage	1500 VAC for one min.	
Contact	1ab	
Port size	3/4, 1	
Standard	EN60947-5-1 ^{Note 1)}	

Note) Suffix "-Q" to the end of product number when ordering.

Micro Switch Ratings

Voltage	Non inductive load (A)				Inductive load (A)			
	Load resistance		Light load		Inductive load		Motor load	
	N.C.	N.O.	N.C.	N.O.	N.C.	N.O.	N.C.	N.O.
125 VAC	15	15	3	1.5	15	15	5	2.5
250 VAC	15	15	2.5	1.25	15	15	3	1.5
8 VDC	15	15	3	1.5	15	15	5	2.5
14 VDC	15	15	3	1.5	10	10	5	2.5
30 VDC	6	6	3	1.5	5	5	5	2.5
125 VDC	0.5	0.5	0.5	0.5	0.05	0.05	0.05	0.05
250 VDC	0.25	0.25	0.25	0.25	0.03	0.03	0.03	0.03

Flow Switch Paddle Style Flow Switch *Series IF3*

Fluid and Ambient Temperature Range

Fluid temperature	Applicable ambient temperature ^(Note)
70°C or less	70°C (70°C) or less
80°C	58°C (60°C) or less
90°C	47°C (50°C) or less
100°C	35°C (40°C) or less

Note) () For IF32□

* To protect the microswitch, ambient temperature must be lowered when the fluid temperature exceeds 70°C.

Construction

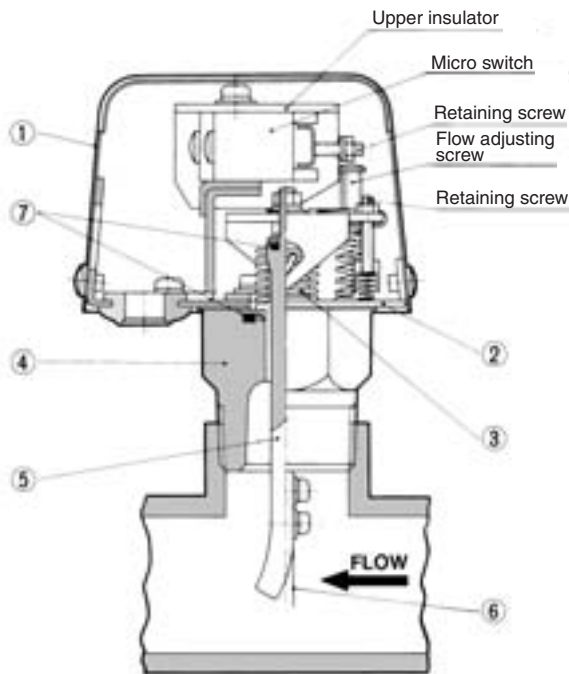

Component Parts

No.	Description	Material		
		IF30□	IF31□	IF32□
1	Cover	SPCD	SPCD	ADC 12
2	Mounting plate	SPCC	Stainless steel 304	Stainless steel 304
3	Bellows	PBP or Stainless steel 304		
4	Body	C3604B or Stainless steel 304		
5	Mobile bar	C2700W or Stainless steel XM7		
6	Paddle	Stainless steel 304		
7	O-ring	NBR or FPM		

Enclosure

Open type	Using indoors away from water drop
Dripproof/Rainproof type (JIS C 0920)	When using indoors or outdoors, where it is exposed to water drop. (Equivalent to IP42)
Splashproof/Low jetproof type (JIS C 0920)	Sealed construction. When using in a bad environment, such as outdoors, or areas exposed to water stream temporarily, or near the coast. (Equivalent to IP44)

Flow Characteristics

Fluid: Water, Outlet pressure: 0 MPa
Sealing thread depth: 9 mm (3/4), 11 mm (1)

Flow switch	Mounting		Flow range (l/min)				ON-flow rate/setting (m/s)
			Minimum		Maximum		
	Port size	Paddle size	ON flow	OFF flow (min)	ON flow	OFF flow (min)	
IF3□0-06	3/4	Long	14	7	38	33	0.66 to 1.79
	3/4	Middle	18	9	50	44	0.85 to 2.36
	3/4	Short	22	11	60	53	1.04 to 2.83
IF3□1-10	1	Short	20	10	60	55	0.56 to 1.67
	1 1/4	Short	34	17	100	90	0.57 to 1.67
	1 1/2	Short	52	26	160	140	0.63 to 1.95
	2	Middle	45	23	140	125	0.34 to 1.06
	2 1/2	Middle	90	45	280	250	0.41 to 1.29
	3	Middle	80	40	250	220	0.26 to 0.81
	4	Long	170	85	550	480	0.33 to 1.05
	5	Long	300	150	1,000	870	0.37 to 1.24
IF3□3-10	6	Long	460	230	1,500	1,300	0.40 to 1.32
	1	Short	36	18	110	100	1.00 to 3.05
	1 1/4	Short	54	27	160	140	0.90 to 2.67
	1 1/2	Short	90	45	270	230	1.10 to 3.29
	2	Middle	90	45	270	230	0.68 to 2.05
	2 1/2	Middle	160	80	500	420	0.74 to 2.30
	3	Long	160	80	500	420	0.52 to 1.63
	4	Long	320	160	1,000	800	0.61 to 1.91
	5	Long	560	280	1,800	1,450	0.69 to 2.23
	6	Long	800	400	2,600	2,000	0.70 to 2.28

ON-flow: Flow volume under which a microswitch starts activation while flow is increasing.

OFF-flow: Flow volume under which a microswitch starts activation while flow is decreasing.

- The maximum flow is twice the maximum ON-flow.
- Data shows the reference value. Operating flow values may differ from those shown above as a result of sealing depth and direction of mounting, piping conditions or variations among individual items, so take precautions when using at levels near the minimum and maximum values of the set flow rate.

PFM

PFMV

PF2A

PF2W

PF2D

IF

Series IF3

ON-flow Change due to Pressure

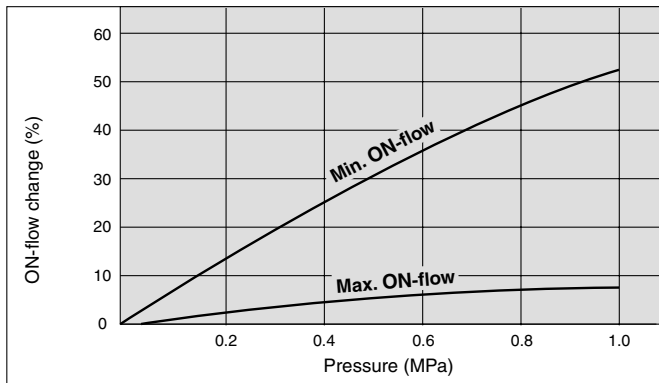

Pressure Drop Curve

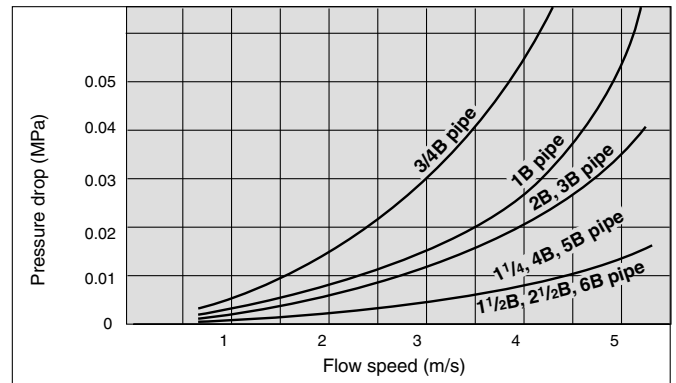

⚠ Precautions

- Be sure to read before handling.
- Refer to front matters 58 and 59 for Safety Instructions and pages 892 to 896 for Flow Switch Precautions.

Mounting & Wiring

⚠ Caution

1. Mount the switch on top of horizontal pipe so that fluid flow is in the direction of the arrow.
Sealing depth should be 9 mm ± 1 mm for 3/4B and 11 mm ± 1.2 mm for 1B.
2. Mounting orientation is only allowed to install it perpendicularly to the horizontal pipe.
3. Provide a straight pipe portion that corresponds to approximately 5 times the bore of the pipe before and after the area of the pipe on which the product is installed, thus keeping the product as far away as possible from the elements that disturb the flow, such as elbows or valves.
4. Three types of paddles, short, medium, and long, are provided with each model. Use one of them according to the pipe size and the set flow rate.
5. When installing a paddle on IF3*O type, piping may be interfered with by the tip of a paddle.
Because this is used to detect a small flow rate, and to narrow the distance between a paddle and piping, additional machining of the paddle tip may be necessary to eliminate interference between the two.
6. Use pipe fittings that comply with JIS specifications.
For 1 1/4B to 3B, use commercially available union tees of different diameters.
For 4B to 6B, use a 1B socket that has been cut in half and welded.
7. When using piping which is non-standard, piping may interfere with the paddle. When this happens, please machine the paddle accordingly.
8. It cannot be used when a water hammer or pulsation pressure is applied to the fluid.

9. Wire the microswitch according to the symbols on the upper insulators. (They will be opposite the terminal symbols on the microswitch. The terminals are screw terminals.)
10. Threads used for the terminals are M4 type.

Internal wiring diagram

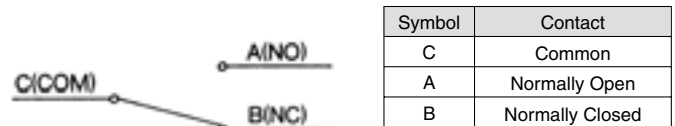

Adjusting

⚠ Caution

1. Flow adjustment is done by turning the flow adjusting screw with Phillips screwdriver. Turning clockwise can increase the set flow and turning counterclockwise can decrease the set flow.
2. Flow rate % relation to the number of turns is shown in the table below. However, this is just a guide. For precise setting use a flow meter.

Flow adjusting screw (Rotations)	0	1	2	3	4	5	6	7	8	9	10	11	12
Contact ON-flow (%)	30	40	50	59	68	74	80	85	89	93	96	98	100

3. The flow rate setting point is set at the ON-flow rate. Therefore, in case of 1a contact, ON signal is output when the fluid with higher flow than the setting flow rate is flown.
In the case of the 1b contact, the ON signal is output when the flow rate has decreased.
Refer to the flow rate characteristics table for details on the operation flow rate.
4. Do not touch the two types of stop screws that are indicated in the construction diagram.
5. To prevent the chattering that is associated with the fluctuation of the operating flow rate, set the difference between the set flow rate and the operating flow rate so that it is as large as possible.
6. Use at or below the maximum operating pressure and maximum flow rate.
7. Spare parts
Short, medium, and long paddles are provided as a 3 piece set with each model, so arrange them as indicated below. There is no compatibility between the paddle for a 3/4" connecting bore and for a 1" because their installation pitches differ.
Arrangement example: Paddle set for IF300-06-00 (Part numbers are not existent.)

Applicable fittings

For pipe fitting 1 1/4B through 3B For pipe fitting 4B through 6B

Piping B	Reducing tees B
1 1/4	1 1/4 x 1 1/4 x 1
1 1/2	1 1/2 x 1 1/2 x 1
2	2 x 2 x 1
2 1/2	2 1/2 x 2 1/2 x 1
3	3 x 3 x 1

Reducing tees: JIS B 2301
Socket : JIS B 2302
Pipe : JIS B 3452

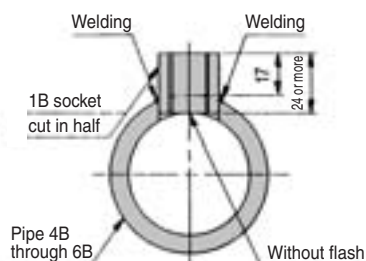

Dimensions

Standard type: 300/301/303

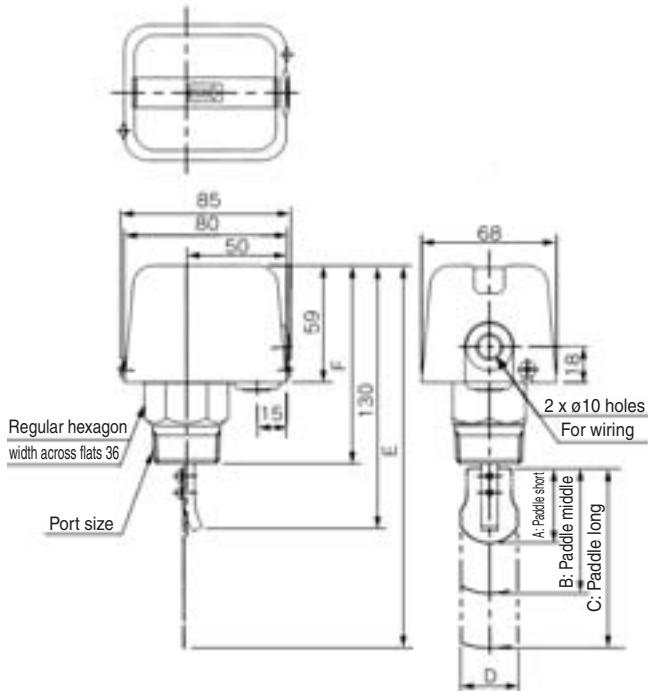

Part no.	Dimensions	Port size	A	B	C	D	E	F
IF300		3/4	28	31	34	22	137	101
IF301		1	37	62	89	28	188	98
IF303		1	29	39	56	28	155	98

Dripproof/Rainproof type: 310/311/313

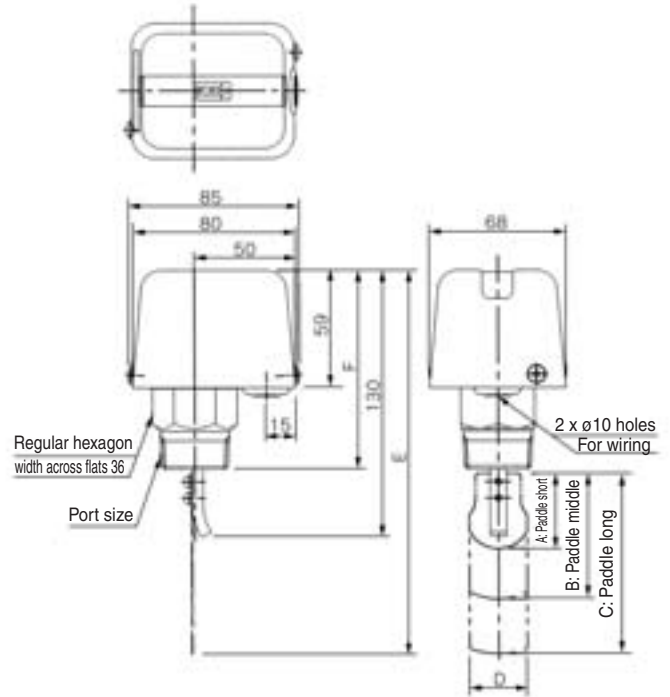

Part no.	Dimensions	Port size	A	B	C	D	E	F
IF310		3/4	28	31	34	22	137	101
IF311		1	37	62	89	28	188	98
IF313		1	29	39	56	28	155	98

Splashproof/Low jetproof type: 320/321/323

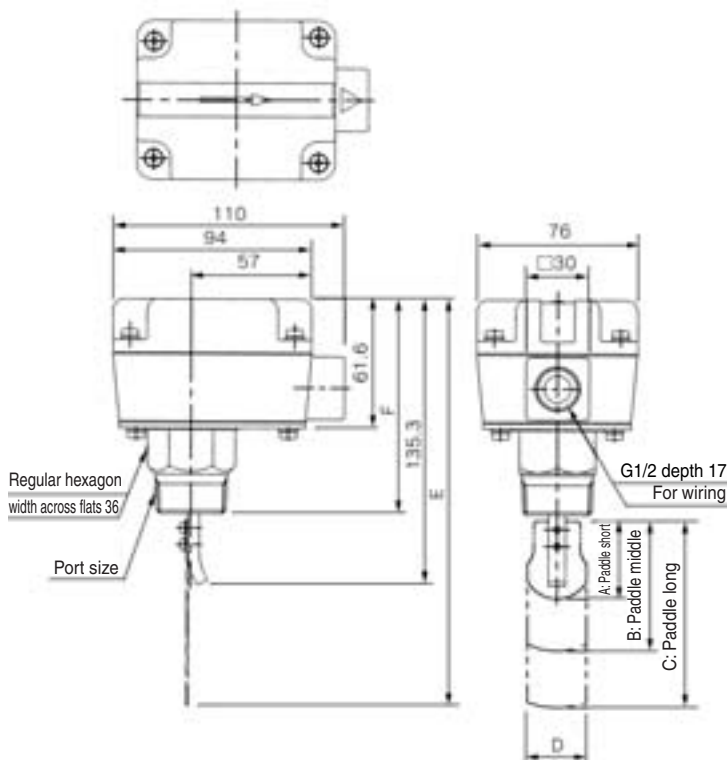

Part no.	Dimensions	Port size	A	B	C	D	E	F
IF320		3/4	28	31	34	22	141.3	105.4
IF321		1	37	62	89	28	194	104
IF323		1	29	39	56	28	161	104

PFM

PFMV

PF2A

PF2W

PF2D

IF

Series IF3

Flow Rate vs. Flow Speed

* Representing value

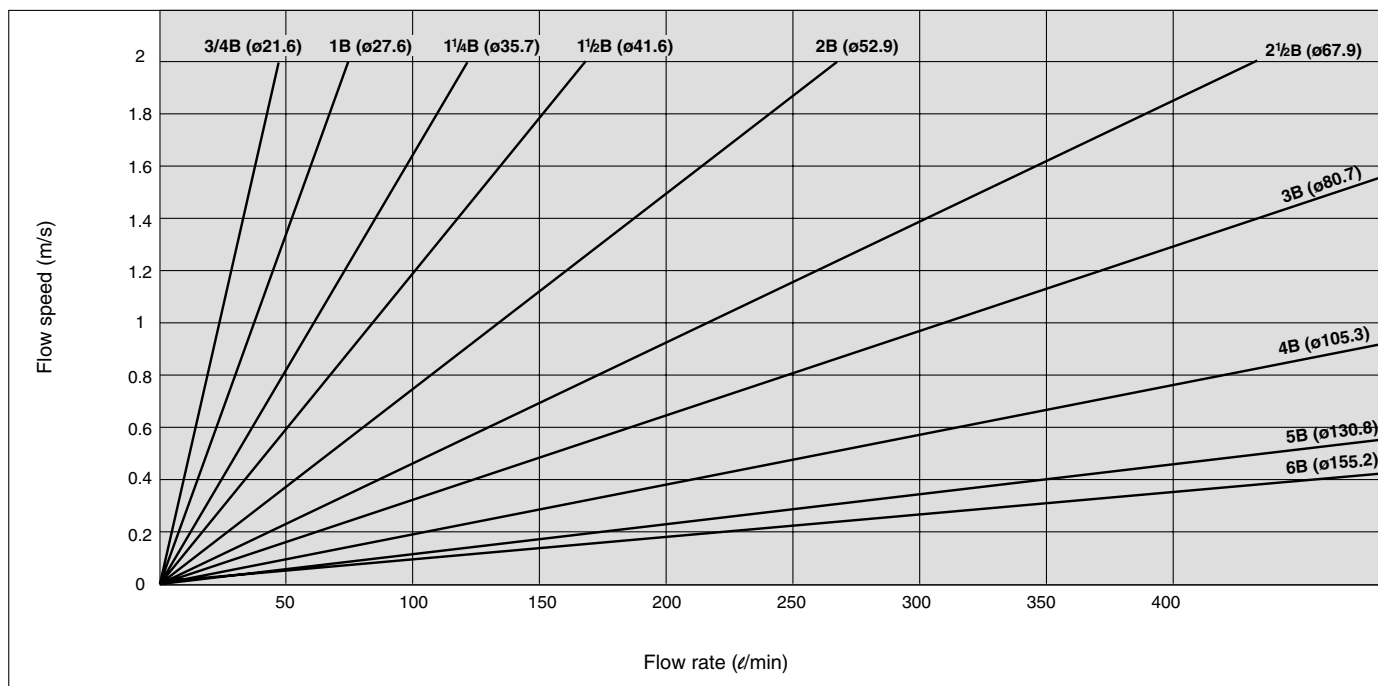

(): Gas pipe bore sizes