

Handheld Electrostatic Meter

Series IZH10

Easy-to-use handheld electrostatic meter



○ Rated charge amount range: ± 20.0 kV

○ Minimum display unit: **0.1** kV (± 1.0 to ± 20.0 kV)
0.01 kV (0 to ± 0.99 kV)



Check the current situation before taking anti-static electricity measures!

- **Compact & Lightweight: 85 g** (excluding dry cell batteries)
- **Peak & Bottom display function**
- **Zero clear function**
- **Auto power-off function**
- **LOW battery indicator**
- **Backlight for reading in the dark**

IZS

IZD
IZE

IZH

Handheld Electrostatic Meter

Series *IZH10*



How to Order

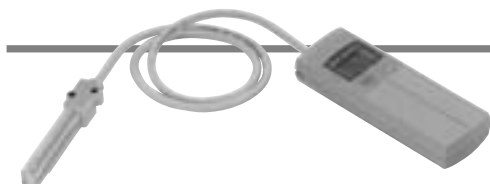

IZH10-□

● Option

Nil	None
H	High-voltage measuring handle

Accessories and Option / Part Number for Individual Parts

* The ground wire and soft case are attached to the IZH series.

Ground wire (1.5 m) / Accessories IZH-A-01

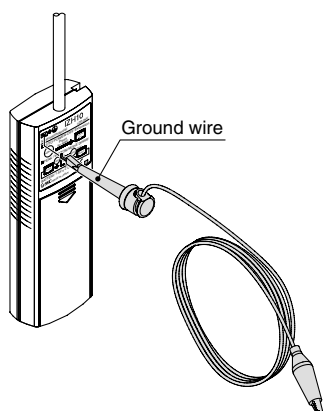

Soft case / Accessories IZH-B-01

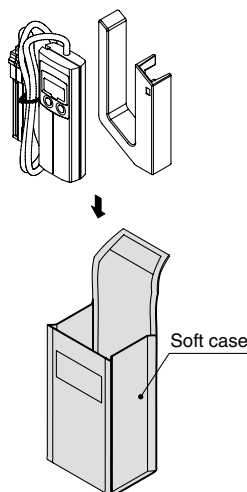

High-voltage measuring handle / Option IZH-C-01

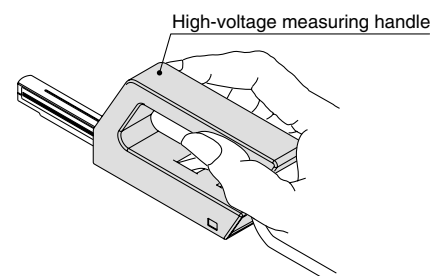

Note) Be sure to use a high-voltage measuring handle in situations such as during high-voltage measurement when there is a possibility of personnel coming in contact with electricity.

Specifications

Model		IZH10
Rated charge amount range		±20.0 kV
Minimum display unit		0.1 kV (±1.0 kV to ±20.0 kV), 0.01 kV (0 to ±0.99 kV)
Measurement distance		50 mm (between sensor part and measured target)
Power supply <small>Note 1)</small>		1.5 VDC 2A alkali dry cell battery, 2 pcs (continuous use for 15 hours or more, see <small>Note 2)</small>)
Display accuracy		±5% F.S. ±1 digit
Environmental resistance	Enclosure	IP40
	Operating temperature range	Operating: 0 to 40°C, Stored: -10 to 60°C (with no freezing or condensation)
	Operating humidity range	Operating/Stored: 35 to 85% R.H. (with no condensation)
	Vibration resistance	10 to 150 Hz at whichever is smaller of 1.5 mm amplitude or 98 m/s ² acceleration, in X, Y, Z directions for 2 hs. each (De-energized)
	Impact resistance	100 m/s ² in X, Y, Z directions 3 times each (De-energized)
Material		Display part: PC/ABS Sensor part: ABS
Mass		85 g (excluding dry cell batteries)
Standards		CE marking
Accessories		Ground wire, Soft case

Note 1) 2A alkali dry cell batteries are not included, and must be acquired separately.
 Note 2) When new alkali dry cell batteries are used at ordinary temperature.

Dimensions (Unit: mm)

Display part

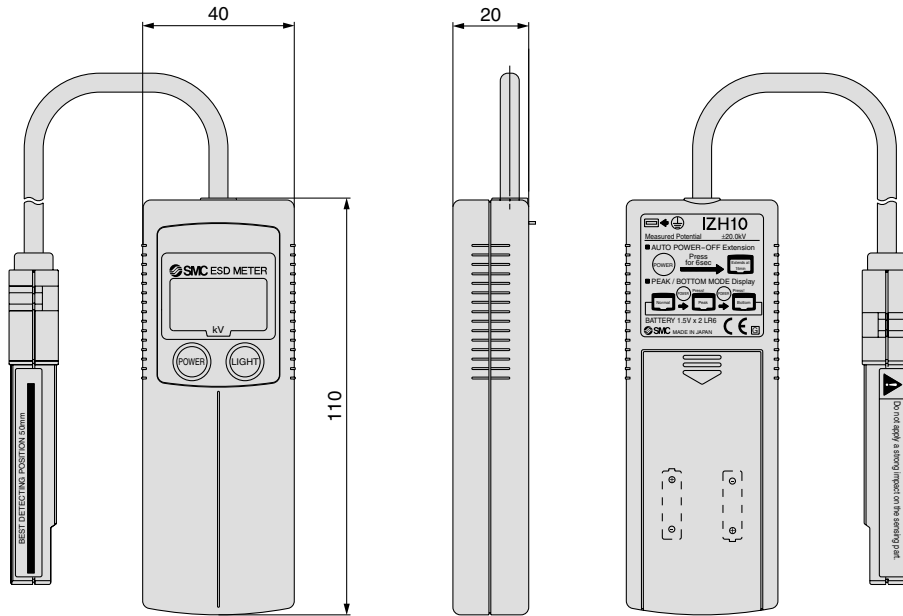

Sensor part

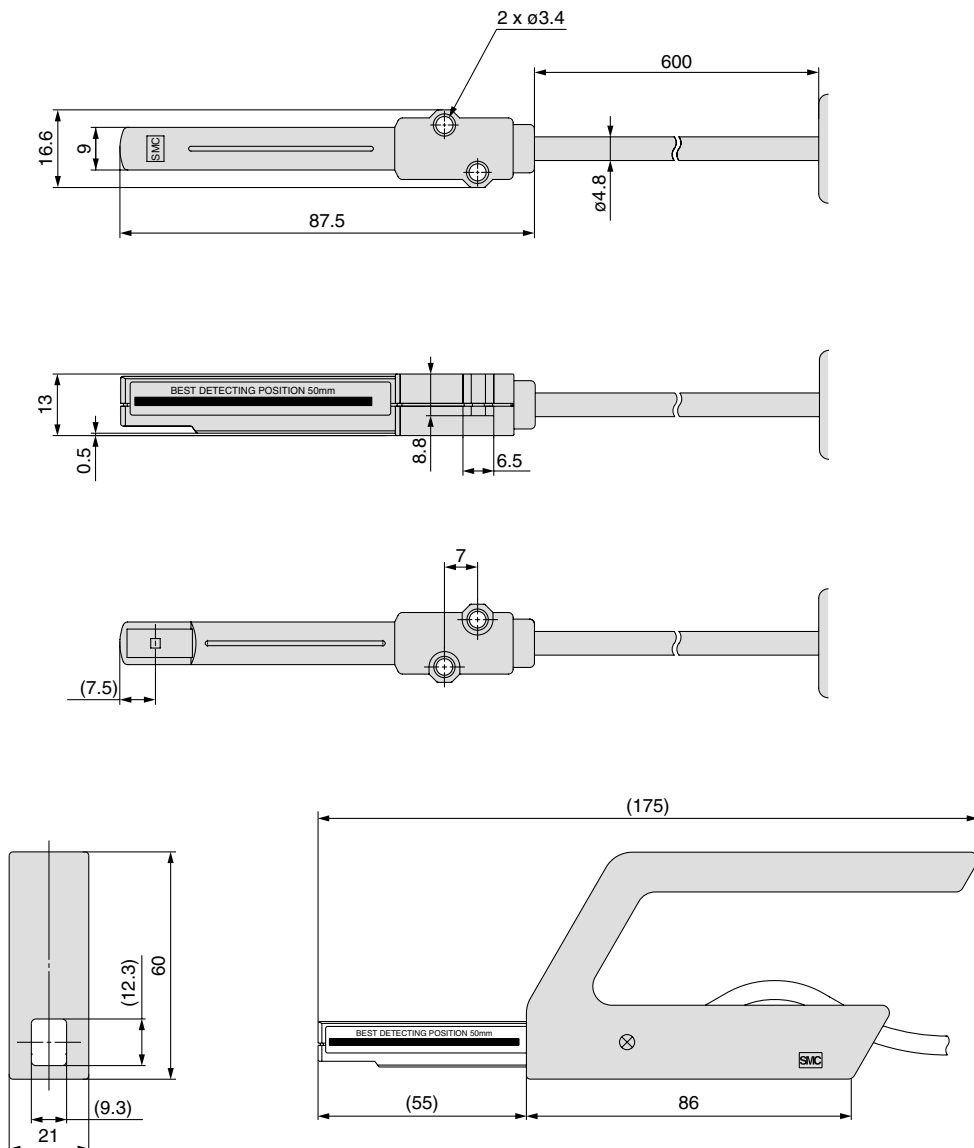

IZS

IZD
IZE

IZH

Names and Functions of Individual Parts

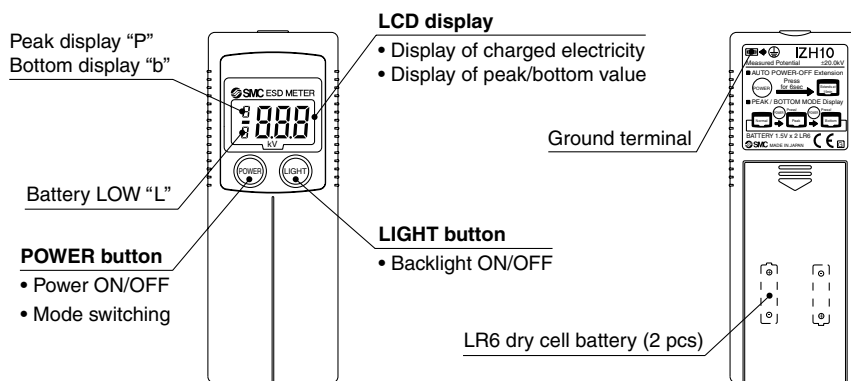

Function Details

A Peak/Bottom display function

The function constantly detects and updates the maximum and minimum electrostatic potential value and allows holding the display value.

B Reset function

The reading of the measured voltage can be adjusted to zero.
The reading can be corrected within $\pm 5\%$ of F.S. from the factory-set condition.

C LOW battery indicator

When the batteries are low it is displayed in two stages: "Battery LOW" and "Replace Battery".
The battery level is indicated by the flashing or lightening up of "L" on the display.

- "L" flashes: Prepare to replace batteries.
- "L" lights up: Replace batteries with new ones.

D Auto power-off function

If no button is operated for 5 min. or more while the power supply is on, the power supply will turn off automatically.
When the [POWER] button is pressed for 6 sec. or more with the power supply off, continuous operating time while no button is pushed will extend to 15 min.

E Light-up of backlight

The display can be easily seen in the dark.
The backlight will be turned on and off by every press of the [LIGHT] button.

F Displayed digit change function

The minimum display digit is changed for the charged potential between -0.99 kV to $+0.99$ kV.

Error Display

Error description	Error display	Condition
Zero clear error	Er 1	A charge over $\pm 5\%$ F.S. of default potential is applied to the sensor. * The indication lasts approx. 1 sec. and then measurement mode returns automatically. There will be a slight displacement, depending on the deviation of the sensor itself and ambient environment.
Sensor error	Er 2	The sensor breaks.
System error	Er 3	Internal display error.
Measurement error	HHH	A charge over the upper limit of the measured voltage range is applied to the sensor, or the distance to the measured target is outside of specified range.
	LLL	A charge over the lower limit of the measured voltage range is applied to the sensor, or the distance to the measured target is outside of specified range.
Cable breakage	—	A broken cable prevents accurate measurement. The charge amount can be detected, but it will not change the displayed value.



Series IZH10

Handheld Electrostatic Meter Precautions

Be sure to read this before handling. Refer to front matters 58 and 59 for Safety Instructions.

Handling Precautions

⚠ Warning

1. **Do not make any modifications (including exchanging the printed circuit board) to the product.**

It may cause human injuries and damage.

2. **Use the device in the condition of specified range.**

Using it out of the specified range may result in fires, electric shock, or damage. Confirm the specifications before using.

3. **Measurement near high-voltage**

Avoid measuring near high-voltage exceeding specifications as it can be dangerous.

4. **Handling of ground wire**

Be sure to provide a ground wire to ensure safety and high-accuracy measurement when using the sensor.

Also, if the ground wire is not connected properly, the power is pooled in the sensor part and/or ground terminal, which can discharge to an operator's hand. Handle the sensor part and ground terminal carefully.

If grounding is not provided,

- Measurement accuracy gets worse.
- The sensor is charged and can discharge to an operator's hand.

5. **Do not apply strong impact.**

Do not drop, allow collision or apply excessive shock to the sensor when handling. It can result in damage of the sensor and accidents.

6. **Distance measurement is 50 mm. Use display of label attached to the sensors as a guide.**

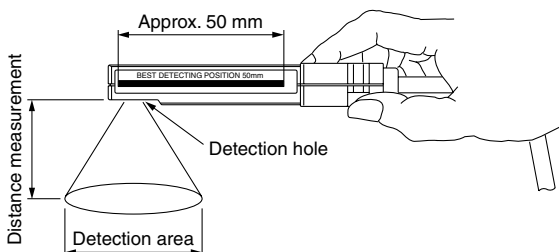

7. **The measurement of a part with a high-charge potential can be highly dangerous as it can cause a discharge to the user's hand.**

In this case, use a handle specific for measuring high voltage, which is available as an option, and wear rubber gloves, etc. Also, gradually bring the sensor part close to the measured target from a distance, and stop the measurement immediately when the displayed value overflows (HHH) or underflows (LLL). (A target with a high-charge potential is very dangerous. The measured value does not change even if the distance is shortened.)

Operating Environment

⚠ Warning

1. Handheld electrostatic meters are CE marked; however, they are not equipped with surge protection against lightning. Lightning surge countermeasures should be applied directly to system components as necessary.
2. Handheld electrostatic meters do not have an explosion proof rating. Never use in the presence of an explosive gas as this may cause a serious explosion.

IZS

IZD
IZE

IZH