

5 Port Direct Operated Solenoid Valve

Series VS4□10

Metal Seal

Model

Number of positions	JIS Symbol	Model	Port size Rc (Nominal size)	Flow characteristics						Max. (1) operating cycle (cpm)		Response (2) time (ms)		Mass (kg) (3)	
				P → A/B			A/B → EA/EB			AC	DC	AC	DC	AC	DC
				C [dm ³ /(s·bar)]	b	Cv	C [dm ³ /(s·bar)]	b	Cv						
2 (Single)		VS4110-01	1/8 (6A)	3.2	0.42	0.86	3.2	0.37	0.80	1,200	180	13 or less	45 or less	0.7	0.82
		VS4110-02	1/4 (8A)	4.0	0.17	0.91	3.4	0.47	0.89						
		VS4110-03	3/8 (10A)	4.1	0.19	0.96	3.9	0.35	1.00						
2 (Double)		VS4210-01	1/8 (6A)	3.2	0.42	0.86	3.2	0.37	0.80	1,200	180	13 or less	40 or less	0.9	1.14
		VS4210-02	1/4 (8A)	4.0	0.17	0.91	3.4	0.47	0.89						
		VS4210-03	3/8 (10A)	4.1	0.19	0.96	3.9	0.35	1.00						
3 (3 position)		VS4310-01	1/8 (6A)	3.1	0.37	0.80	3.2	0.35	0.82	360	180	15 or less	45 or less	0.98	1.22
		VS4310-02	1/4 (8A)	3.8	0.23	0.89	3.6	0.33	0.89						
		VS4310-03	3/8 (10A)	4.2	0.23	1.00	3.8	0.32	0.99						
		VS4410-01	1/8 (6A)	3.1	0.28	0.77	3.0	0.28	0.75	360	180	15 or less	45 or less	0.98	1.22
		VS4410-02	1/4 (8A)	3.9	0.22	0.94	3.5	0.27	0.84						
		VS4410-03	3/8 (10A)	4.0	0.26	1.00	3.7	0.32	0.94						

Note 1) Min. operating frequency is once every 30 days. (Based on JIS B 8375.)

Note 2) Based on JIS B 8375-1981. (At the pressure of 0.5 MPa, without surge suppressor)

Note 3) Electrical entry: From sub-plate

Note 4) "Note 1)" and "Note 2)" are with controlled clean air.

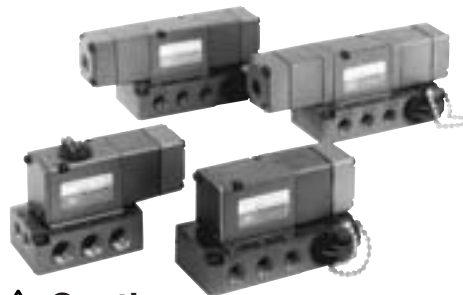

Caution

Be sure to read before handling. Refer to front matters 58 and 59 for Safety Instructions and pages 3 to 7 for 3/4/5 Port Solenoid Valve Precautions.

How to Calculate the Flow Rate

For obtaining the flow rate, refer to front matters 44 to 47.

Standard Specifications

Fluid	Air/Inert gas	
Operating pressure range	0 to 1.0 MPa	
Ambient and fluid temperature	-20 to 60°C*	
Manual override	Possible	
Electrical entry	Grommet, Conduit, DIN terminal, Conduit terminal	
Lubrication	Non-lube	Usable with non-lube
	Lubrication	Use turbine oil Class 1 (ISO VG32), if lubricated.
Impact/Vibration resistance (m/s ²)	150/50 ^{Note)}	
Manifold	Possible	

* Use dry air (Dew point: -20°C or less). If using a lubricant, be sure to use a lubricant for low temperatures.
 Note) Impact resistance: No malfunction occurred when it is tested with a drop tester in the axial direction and at the right angles to the main valve and armature in both energized and de-energized states every once for each condition. (Values at the initial period)

Vibration resistance: No malfunction occurred in a one-sweep test between 45 and 2000 Hz. Test was performed at both energized and de-energized states in the axial direction and at the right angles to the main valve and armature. (Values at the initial period)

Solenoid Specifications

Coil rated voltage	100, 200 VAC, 50/60 Hz; 24 VDC
Allowable voltage fluctuation	-15 to +10% of rated voltage
Coil insulation type	Class B or equivalent (130°C) ^{Note)}

Note) Based on JIS C 4003

How to Order

VS 4 1 1 0 - 02 1 C L - □

Direct operated/Metal seal solenoid valve
4, 5 port valve

Type of actuation

1	Single
2	Double
3	3 position (Closed center)
4	3 position (Exhaust center)

Body size: 1/8 standard

Piping

0	Side ported
1	Bottom ported
4	Without sub-plate (For manifold)

Port size (Nominal size)

00	Without sub-plate
01	Rc 1/8 (6A)
02	Rc 1/4 (8A)
03	Rc 3/8 (10A)

Voltage

1	100 VAC, 50/60 Hz
2	200 VAC, 50/60 Hz
3	110 VAC *
5	220 VAC *
5	24 VDC
9	Other

* Option

Electrical entry

Symbol	Electrical entry position	Electrical entry
C	Sub-plate	Conduit
T	Sub-plate	Conduit with terminal
U	Valve body	Grommet
D	Valve body	DIN terminal

Thread type

Nil	Rc
N *	NPT
T *	NPTF
F *	Parallel thread

* Option

Accessory

L	Indicator light (DC is possible only for DL.)
P	Manual override

Series VS4□10

Apparent Power (Power Consumption)

Apparent power (VA) (Power consumption (W))	AC	Inrush	50Hz	51 VA (64 VA *)
			60Hz	45 VA (55 VA *)
		Holding	50Hz	17 VA (5.3/5.5 W)
			60Hz	11 VA (2.9/3.2 W)
Power consumption (W)	DC			5.5



* In the case of 3 position type.

Option Specifications

- Bottom ported (Sub-plate)
- Coil rated voltage (110/220 VAC, 12/100 VDC)

Enclosure (Based on JIS C 0920)

Electrical entry	Grommet (Sub-plate/ Valve body)	Conduit	DIN terminal	Conduit terminal
Dustproof	Standard	Standard	Standard	Standard
Dripproof	—	Option	Option	Option

Construction Principle

VS4110

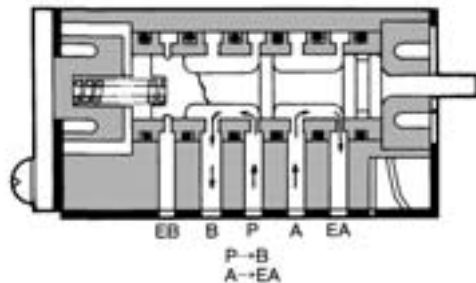

VS4210

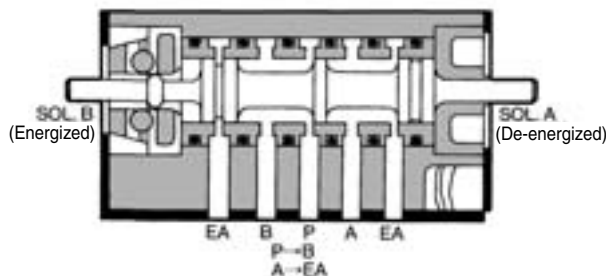

VS4310 (Closed center)

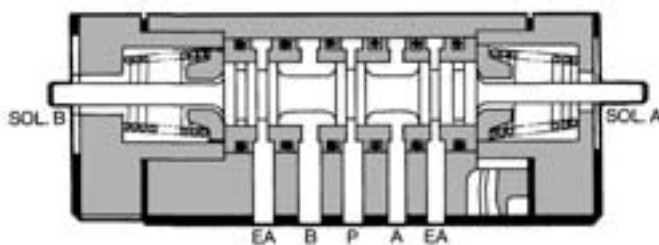

Accessory (Option)

1. Indicator light (AC)

When solenoid gets energized, indicator light illuminates, thus electrical states of the solenoid can be seen from the outside.

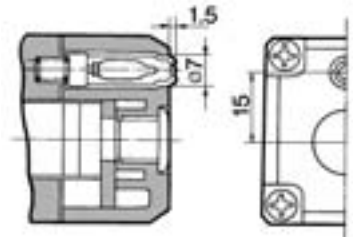

With rubber plug	Manual override		Applicable model
	Non-locking	With lock	
SC0003-□	SC0004B-□	SC0004A-□	VS4110 VS4210
SC0013-□	SC0014B-□	SC0014A-□	VS4310 VS4410

* Indicate the voltage to be used.
(100 VAC: 01, 200 VAC: 02)

2. Manual override

Remove rubber plug at the top of the solenoid cap to install manual override. Push the override with a screwdriver to the required stroke and the valve will shift. With the override in the same position, turn it to the right or left 90° and it will lock. Turn it back 90° to unlock.

⚠ Caution

Be sure to unlock it before energizing the valve electrically.

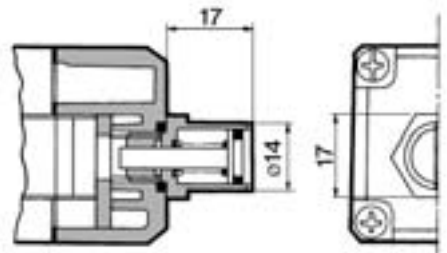

Description	Part no.	Applicable model
Manual override (With lock)	AC PB0111	VS4110 VS4310 VS4410
	DC PB0111-1	
Manual override (Non-locking)	AC PB0101	VS4210
	DC PB0101-1	

[In the case of a 2 position double solenoid valve, use a non-locking manual override because it has a locking function in the main valve.]

3. Terminal wiring

- Lead wire from the solenoid is connected to the lower terminal of the terminal block under the junction cover of sub-plate. Connect the lead wire of the power supply corresponding to the solenoid (single solenoid: A side/double solenoid: both A and B sides) to the upper terminal of the terminal block.

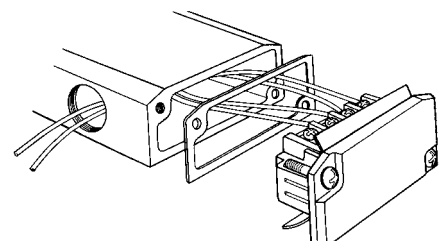

Construction

VS4110

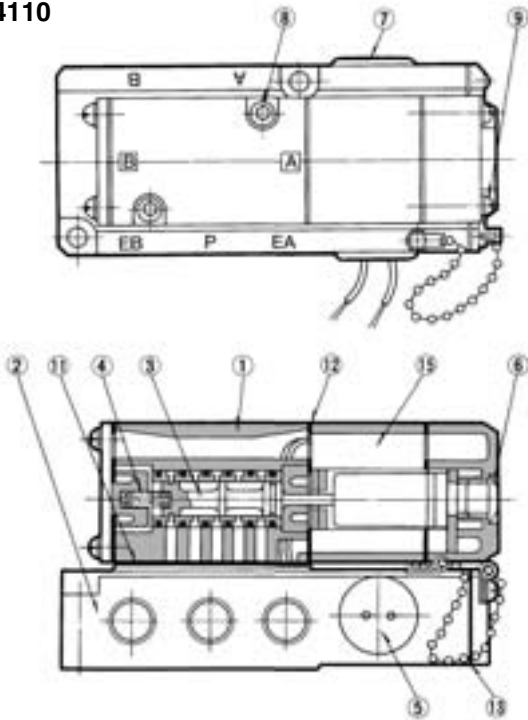

VS4210

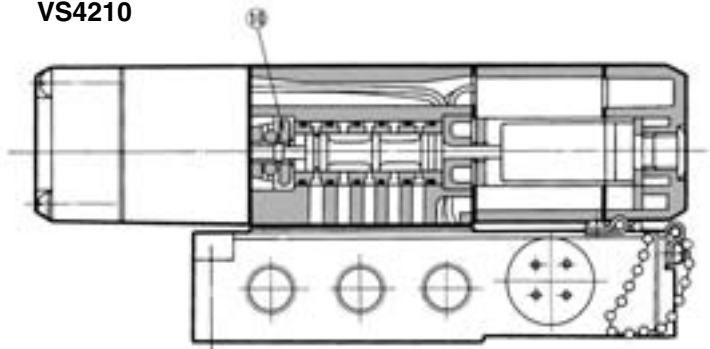

VS4310/4410

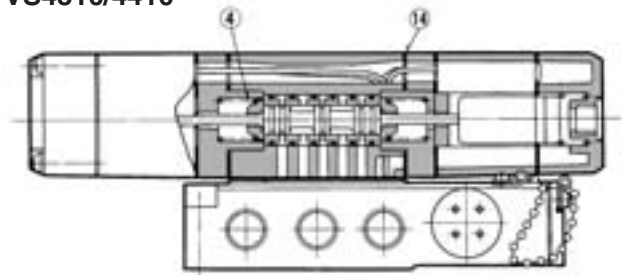

Sub-plate Assembly Part No.

Electrical entry	Part no.
C: Conduit	VS4010-CS- 01 02 03
T: Conduit terminal	VS4010-TS- 01 02 03
U: Grommet, D: DIN terminal	VS4010-S- 01 02 03

* Mounting bolt and gasket are not included.

Part No. for Mounting Bolt and Gasket

BG-VS4010

Component Parts

No.	Description	Material	Note
1	Body	Aluminum die-casted	Platinum silver
2	Sub-plate	Aluminum die-casted	Platinum silver
3	Spool/Sleeve	Stainless steel	

Replacement Parts

No.	Description	Material	Part no.		
			VS4110	VS4210	VS4310/VS4410
4	Spring	Piano wire	AXT333-9-3	—	AXT333-22-3
5	Rubber plug for wire	NBR	XT010-20	XT012-24	XT012-24
6	Plug for cap	NBR	AXT333-16	AXT333-16	AXT333-16
7	Rubber plug	NBR	AXT333-12	AXT333-12	AXT333-12
8	Mounting bolt	Carbon steel	AXT333-17	AXT333-17	AXT333-17
9	Mounting screw	Carbon steel	AXT333-19 (AXT333-31-4)	AXT333-19 (AXT333-31-4)	DXT020-36 (AXT333-31-5)
10	Detent assembly	NBR	—	AXT333-20	—
11	Gasket	NBR	AXT335-12-3	AXT335-12-3	AXT335-12-3
12	Gasket	NBR	AXT333-14	AXT333-14	AXT333-14
13	Gasket	NBR	AXT333-15	AXT333-15	AXT333-15
14	Gasket	NBR	—	—	AXT334-7

(): For DC

15 Solenoid Capsule Assembly (With rubber plug)

	Specifications	Part no.	
		VS4110/4210	VS4310/4410
Standard	Grommet/Conduit	SCA001-□	SCA011-□
	DIN terminal	SCAD001-□	SCAD011-□
Option	Indicator light (AC only)	SCA003-□	SCA013-□

* Indicate the used voltage.(100 VAC: 01, 200 VAC: 02, 24 VDC: 52)

VV061
V100
S070
VQD
VKF
VK
VT
VS

Series VVS410

Manifold Specifications

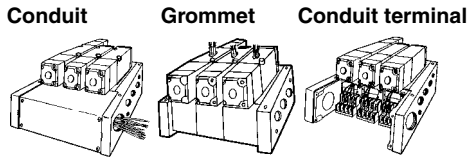

Specifications

Applicable valve	VS4110/4210/4310/4410
Valve stations	Max. 10 stations (Standard)
Accessory	With terminal * With interface regulator * With stop valve/With flow controls

* Option

Standard Piping Specifications

Type	Configuration	Port size Rc			Conduit * port size G
		P	A, B	EA, EB	
Common EXH		1/4, 3/8 (Side)	1/8, 1/4 (Side)	1/4, 3/8 (Side)	1, 1 1/4
Individual EXH		1/4, 3/8 (Side)	1/8, 1/4 (Side)	1/8, 1/4 (Bottom)	

* Optional piping: Individual SUP and different pressure SUP. But it will be the bottom porting specifications.
Note) Each port size will be a big size for standard. When the small size is desired, indicate separately.

How to Order

VV S 4 1 0 - 05 SC 1 T -

Valve Manifold base

Applicable valve series
S VS4□10

Applicable valve
4 way

Applicable valve
Base size: 1/8

Porting specifications

Symbol	P	A, B	EA, EB
0	Side	Side	Side
1	Side	Bottom	Side
9	Other		

Electrical entry

Symbol	Electrical entry position
SC	Manifold block
SU	Valve body

Manifold specifications

Symbol	SUP	EXH
1	Common	Common
2	Common	Individual
3	Individual	Common
4	Individual	Individual
5	Dissimilar pressure	Common
6	Dissimilar pressure	Individual

Valve stations

02	2 stations
⋮	⋮
05	5 stations
⋮	⋮
10	10 stations

Thread type

Nil	Rc
N *	NPT
T *	NPTF
F *	Parallel thread

* Option

Accessory

T *	With terminal
S	With stop valve
R	With throttle valve

* Type SC only.

⚠ Precautions

Be sure to read before handling. Refer to front matters 58 and 59 for Safety Instructions and pages 3 to 7 for 3/4/5 Port Solenoid Valve Precautions.

Mounting

⚠ Caution

- SUP port and EXH port are positioned on both sides of manifold block. Air can be supplied from either side; however, the unused port must be plugged in this case. When operating 6 or more valve stations within a manifold at the same time, take SUP air pressure from both sides and open EXH port to the atmosphere.
- When manifolding an exhaust center 3 position valve, use the individual EXH style manifold. (Back pressure may cause actuator to malfunction.)

Series VVS410

Construction

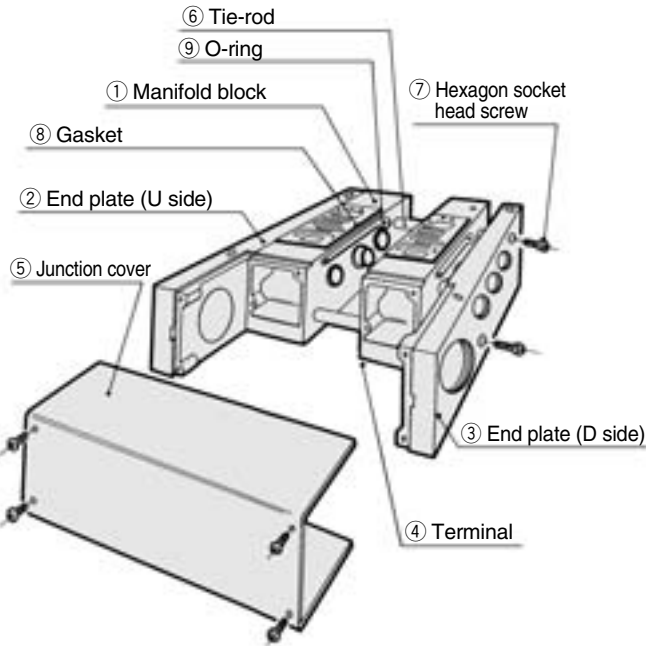

• Replacement Parts: Sub-assembly

No.	Description	Assembly part no.	Electrical entry
1	Manifold block assembly	AXT336-1A-1 ⁰¹ / ₀₂	Type SC (T only)
		AXT336-1A-2 ⁰¹ / ₀₂	Type SU
		AXT336-1A-3 ⁰¹ / ₀₂	Type SC
2	End plate (U side) assembly	AXT336-2A-1- ⁰² / ₀₃	Type SC
		AXT336-2A-2- ⁰² / ₀₃	Type SU
3	End plate (D side) assembly	AXT336-3A-1- ⁰² / ₀₃	Type SC
		AXT336-3A-2- ⁰² / ₀₃	Type SU
4	Terminal assembly	AXT622-5A	
5	Junction cover assembly	AXT336-4A- ^{Stations}	
6	Tie-rod	AXT336-5- ^{Stations}	

• Replacement Parts

No.	Description	Material	Part no.
7	Hexagon socket head screw	Carbon steel	M6 x 25
8	Gasket	NBR	AXT335-12-3
9	O-ring	NBR	AS568-015

• Manifold Optional Parts Assembly

Option	Part no.
Blanking plate	AXT336-7A
Throttle valve spacer	AXT392A
Stop valve spacer	AXT395A
Interface regulator	ARB110-00- ¹ (P port regulation) ² (A/B port regulation)
Block disk	AXT336-6
Rubber plug	AXT336-9

Dimensions

Type SC

(Electrical entry position:
Manifold block)

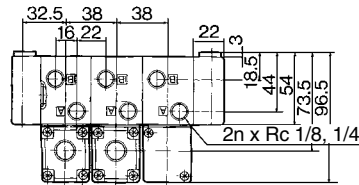

Formula/Stations	2	3	4	5	6	7
$L_1 = 38n + 27$	103	141	179	217	255	293
$L_2 = 38n + 44$	120	158	196	234	272	310

Formula for manifold weight M = 0.405n + 0.49 (kg)

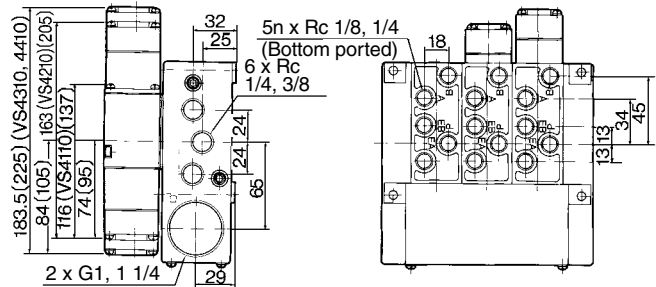
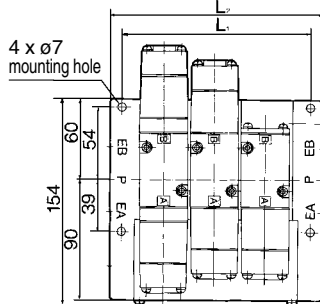

Type SU

(Electrical entry position:
Valve body)

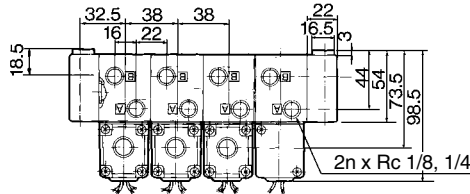

Formula/Stations	2	3	4	5	6	7
$L_1 = 38n + 27$	103	141	179	217	255	293
$L_2 = 38n + 44$	120	158	196	234	272	310

Formula for manifold weight M = 0.325n + 0.39 (kg)

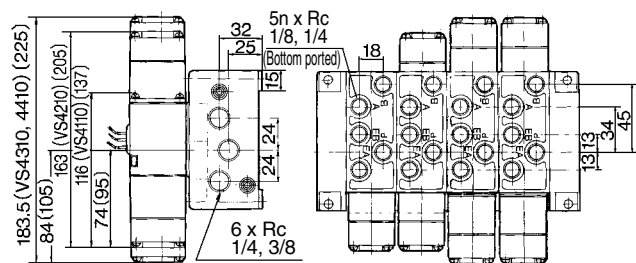
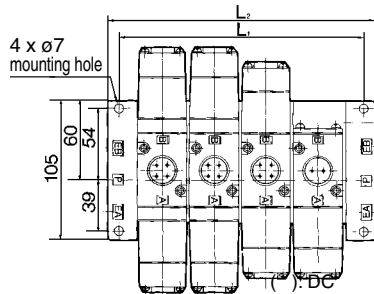

() : DC